

Wallace & Tiernan[®]

an eVOQUA brand

VACUUM REGULATOR-CHECK UNIT

MODEL 510 M/S

500 LB/24 HR CAPACITY FOR Cl₂, SO₂, CO₂

BOOK NO. WT.025.510.001.UA.IM.0914

W3T100315

**VACUUM
REGULATOR-CHECK UNIT
MODEL 510 M/S
500 LB/24 HR CAPACITY
FOR Cl₂, SO₂, OR CO₂**

BOOK NO. WT.025.510.001.UA.IM.0914

EQUIPMENT SERIAL NO. _____

DATE OF START-UP _____

START-UP BY _____

Prompt service available from nationwide authorized service contractors.

ORDERING INFORMATION

In order for us to fill your order immediately and correctly, please order material by description and part number, as shown in this book. Also, please specify the serial number of the equipment on which the parts will be installed.

WARRANTY

Seller warrants for a period of one year after shipment that the equipment or material of its manufacture is free from defects in workmanship and materials. Corrosion or other decomposition by chemical action is specifically excluded as a defect covered hereunder, except this exclusion shall not apply to chlorination equipment. Seller does not warrant (a) damage caused by use of the items for purposes other than those for which they were designed, (b) damage caused by unauthorized attachments or modifications, (c) products subject to any abuse, misuse, negligence or accident, (d) products where parts not made, supplied, or approved by Seller are used and in the sole judgment of the Seller such use affects the products' performance, stability or reliability, and (e) products that have been altered or repaired in a manner in which, in the sole judgment of Seller, affects the products' performance, stability or reliability. **SELLER MAKES NO OTHER WARRANTY OF ANY KIND, AND THE FOREGOING WARRANTY IS IN LIEU OF ALL OTHER WARRANTIES, EXPRESS OR IMPLIED, INCLUDING ANY WARRANTY OF MERCHANTABILITY OR OF FITNESS OF THE MATERIAL OR EQUIPMENT FOR ANY PARTICULAR PURPOSE EVEN IF THAT PURPOSE IS KNOWN TO SELLER.** If Buyer discovers a defect in material or workmanship, it must promptly notify Seller in writing; Seller reserves the right to require the return of such defective parts to Seller, transportation charges prepaid, to verify such defect before this warranty is applicable. In no event shall such notification be received by Seller later than 13 months after the date of shipment. No action for breach of warranty shall be brought more than 15 months after the date of shipment of the equipment or material.

LIMITATION OF BUYER'S REMEDIES. The **EXCLUSIVE REMEDY** for any breach of warranty is the replacement f.o.b. shipping point of the defective part or parts of the material or equipment. Any equipment or material repaired or replaced under warranty shall carry the balance of the original warranty period, or a minimum of three months. Seller shall not be liable for any liquidated, special, incidental or consequential damages, including without limitation, loss of profits, loss of savings or revenue, loss of use of the material or equipment or any associated material or equipment, the cost of substitute material or equipment, claims of third parties, damage to property, or goodwill, whether based upon breach of warranty, breach of contract, negligence, strict tort, or any other legal theory; provided, however, that such limitation shall not apply to claims for personal injury.

Statements and instructions set forth herein are based upon the best information and practices known to Evoqua Water Technologies, but it should not be assumed that every acceptable safety procedure is contained herein. Of necessity this company cannot guarantee that actions in accordance with such statements and instructions will result in the complete elimination of hazards and it assumes no liability for accidents that may occur.



725 Wooten Road
Colorado Springs, Co 80915

INTRODUCTION

This instruction book provides installation, operation, and service instructions for the Wallace & Tiernan® 500 lb/24 hour capacity Vacuum Regulator-Check Unit. The vacuum regulator-check unit is designed to regulate the gas supply to Wallace & Tiernan® Chlorinators or Feeders for sulfur dioxide or carbon dioxide.

Instructions for the chlorinator (or other gas feeders) are provided in a separate instruction book, which also provides important precautionary information for the gas being handled and includes the appropriate gas manual referred to below. Both instruction books are required to properly install, operate, and maintain this combination of equipment.

For swimming pool, water park, or similar non-residential recreational applications, contact your Evoqua Water Technologies representative for information concerning specific systems designed for such use.



WARNING: TO AVOID POSSIBLE SEVERE PERSONAL INJURY OR DAMAGE TO THE EQUIPMENT, THIS EQUIPMENT SHOULD BE INSTALLED, OPERATED, AND SERVICED ONLY BY TRAINED, QUALIFIED PERSONNEL WHO ARE THOROUGHLY FAMILIAR WITH THE ENTIRE CONTENTS OF THIS INSTRUCTION BOOK AND THE APPROPRIATE GAS MANUAL. WHEN THE EQUIPMENT DESCRIBED IN THIS BOOK IS USED WITH CARBON DIOXIDE, REGULATORS, REDUCING VALVES, AND PRESSURE RELIEF VALVES, ALL RELATED LINES AND FITTINGS BETWEEN THE GAS SUPPLY AND THE VACUUM REGULATOR MUST BE OBTAINED FROM THE GAS SUPPLIER AND INSTALLED IN ACCORDANCE WITH THEIR RECOMMENDATIONS (DRAWINGS AND TEXT IN THIS BOOK RELATING TO CHLORINE SUPPLY ARE NOT APPLICABLE TO CARBON DIOXIDE SYSTEMS). GAS SUPPLY PRESSURE MUST BE REDUCED TO 20-220 PSIG TO PREVENT OVERPRESSURIZATION OF THE VACUUM REGULATOR; A PRESSURE RELIEF DEVICE SET AT 230 PSIG MAXIMUM MUST BE INSTALLED BETWEEN THE PRESSURE REDUCING VALVE AND THE VACUUM REGULATOR.

NOTE: The appropriate Gas Handling Manual is provided as part of the instruction book for the control unit used in conjunction with this equipment.

NOTE: When ordering material always specify model and serial number of apparatus.

TABLE OF CONTENTS

	PAGE/DWG. NO.
Very Important Safety Precautions.....	SP-1,-2
Carbon Dioxide	1.010-33,-34
Sulfur Dioxide	1.010-37,-38
Chlorine	1.010-40,-41
Flexible Connection Replacement	1.010-4
Preventive Maintenance General	
Information	1.010-5
Maintenance Record Card	1.010-13
Regional Offices	1.010-1
Identification	
Vacuum Regulator Switchover	25.210.150.010
Technical Data.....	2
Installation.....	2 through 9
Operation	9
Service	10 through 12
Important Safety Instructions for Auxiliary	
Cylinder Valve	12 through 13
Warning/Caution Labels.....	14
Flow Diagram - Automatic Switchover	
Vacuum Regulator.....	25.210.180.010
Typical Installation	
Supply Connections	25.510.110.010
AAA3704 Vacuum Alarm Switch	25.510.110.030
Installation Wiring - Optional Vacuum Switch &	
Alarm System	25.510.130.010
Installation Piping - Manifold Vacuum	
Regulator-Check Unit	25.510.120.010A&B
Parts	
Vacuum Regulator (Standard).....	25.510.000.010A&B
Vacuum Regulator (Automatic Switchover).....	25.510.000.020A-D
Ton Container Kit	25.510.001.010
U28110 Auxiliary Cylinder Valves	50.150.001.012
Flexible Connections & Accessories.....	50.150.007.021
Preventive Maintenance Kit	
& Spare Parts List	30 through 31
Chlorine Handling Manual.....	WT.025.000.001.UA.IM

VERY IMPORTANT SAFETY PRECAUTIONS

This and the following pages titled "Very Important Safety Precautions" provide, in brief, information of urgent importance relative to safety in the installation, operation, and maintenance of this equipment.

WARNING

TO AVOID POSSIBLE SEVERE PERSONAL INJURY OR EQUIPMENT DAMAGE, OBSERVE THE FOLLOWING

THIS EQUIPMENT IS SUITABLE FOR USE ONLY WITH THE GASES SPECIFIED. DO NOT USE WITH OTHER GASES. SUCH USE CAN RESULT IN MALFUNCTION OR FAILURE OF VARIOUS COMPONENTS HAVING HAZARDOUS CONSEQUENCES.

ALWAYS USE A NEW LEAD GASKET WHEN INSTALLING A VACUUM REGULATOR AND EACH TIME A SUPPLY CYLINDER IS CHANGED. NEVER REUSE GASKETS.

WHEN MAKING LEAK CHECKS, IT IS RECOMMENDED PRACTICE TO HAVE AN APPROVED GAS MASK AVAILABLE THAT YOU HAVE BEEN TRAINED TO USE.

DO NOT TOLERATE ANY LEAKS. LEAKS ALWAYS GET PROGRESSIVELY WORSE AND MUST BE CORRECTED PROMPTLY.

CYLINDERS AND TON CONTAINERS MUST BE SECURED IN SUCH A MANNER (e.g., CHAIN OR CHOCKS) AS TO PREVENT THEIR BEING KNOCKED OVER OR ROLLED OUT OF PLACE.

TO PREVENT ELECTRICAL SHOCK, TURN POWER OFF BEFORE SERVICING. ALLOW HEATERS TO COOL BEFORE SERVICING TO PREVENT BURNS.

DO NOT DISCARD THIS INSTRUCTION BOOK UPON COMPLETION OF INSTALLATION. INFORMATION PROVIDED IS ESSENTIAL TO PROPER AND SAFE OPERATION AND MAINTENANCE.

ADDITIONAL OR REPLACEMENT COPIES OF THIS INSTRUCTION BOOK ARE AVAILABLE FROM:

Evoqua Water Technologies
725 Wooten Road
Colorado Springs, CO 80915
Phone: (800) 524-6324

NOTE

Minor part number changes may be incorporated into Evoqua Water Technologies products from time to time that are not immediately reflected in the instruction book. If such a change apparently has been made in your equipment and does not appear to be reflected in your instruction book, contact your local Evoqua Water Technologies sales office for information.

Please include the equipment serial number in all correspondence. It is essential for effective communication and proper equipment identification.

VERY IMPORTANT SAFETY PRECAUTIONS - CARBON DIOXIDE

This and the following pages titled “Very Important Safety Precautions” provide, in brief, information of urgent importance relative to safety in the installation, operation, and maintenance of this equipment.

WARNING

TO AVOID POSSIBLE SEVERE PERSONAL INJURY OR EQUIPMENT DAMAGE, OBSERVE THE FOLLOWING:

THIS EQUIPMENT SHOULD BE INSTALLED, OPERATED, AND SERVICED ONLY BY TRAINED, QUALIFIED PERSONNEL WHO ARE THOROUGHLY FAMILIAR WITH THE ENTIRE CONTENTS OF THIS INSTRUCTION BOOK AND THE CARBON DIOXIDE GAS HANDLING MANUAL.

EXPOSURE TO CARBON DIOXIDE GAS IN HIGH CONCENTRATION MAY CAUSE SUFFOCATION AND DEATH.

DO NOT TOLERATE ANY CARBON DIOXIDE LEAKS. LEAKS NEVER GET BETTER. LEAKS ALWAYS GET PROGRESSIVELY WORSE IF THEY ARE NOT PROMPTLY CORRECTED. IT IS RECOMMENDED PRACTICE TO HAVE AN APPROVED GAS MASK AVAILABLE WHEN MAKING LEAK CHECKS.

AS SOON AS THERE IS ANY INDICATION OF A LEAK, TAKE IMMEDIATE STEPS TO CORRECT THE CONDITION.

IMPORTANT INFORMATION RELATED TO SAFETY OF CARBON DIOXIDE EQUIPMENT INSTALLATION IS PROVIDED IN THE CARBON DIOXIDE GAS HANDLING MANUAL. IN THE INTEREST OF SAFE OPERATION, AND TO AVOID THE POSSIBILITY OF PERSONAL INJURY, THIS INFORMATION MUST BE READ, UNDERSTOOD, AND PRACTICED BY EQUIPMENT OPERATORS AND THEIR SUPERVISORS.

AT TIME OF INITIAL INSTALLATION, WHEN CARBON DIOXIDE SUPPLY LINES HAVE BEEN DISCONNECTED FOR ANY REASON, AND ON A ROUTINE DAILY BASIS, THOROUGHLY CHECK ALL JOINTS, CONNECTIONS, AND EQUIPMENT FOR POSSIBLE LEAKS AND IMMEDIATELY CORRECT ANY THAT MAY BE FOUND.

THE TWO MOST COMMON CAUSES OF CARBON DIOXIDE PIPING LEAKS ARE:

1. RE-USE OF GASKETS. THIS SHOULD NEVER BE DONE. ALWAYS HAVE AN ADEQUATE SUPPLY ON HAND AND ALWAYS USE NEW GASKETS OF THE CORRECT MATERIAL AND SIZE AS IDENTIFIED ON THE EQUIPMENT PARTS DRAWINGS.
2. IMPROPERLY MADE-UP THREADED PIPE JOINTS. JOINTS SHOULD BE MADE UP USING A SUITABLE THREAD DOPE OR FLUOROCARBON PLASTIC TAPE.

USE ONLY EVOQUA WATER TECHNOLOGIES LISTED PARTS, EXCEPT FOR THOSE COMMERCIALY AVAILABLE PARTS THAT ARE IDENTIFIED BY COMPLETE DESCRIPTION ON THE PARTS LIST. THE USE OF UNLISTED PARTS CAN RESULT IN EQUIPMENT MALFUNCTIONS AND HAVE HAZARDOUS CONSEQUENCES.

EXCEPT IN CASES OF LEAK DETECTION OR CALIBRATION ADJUSTMENTS, THE CARBON DIOXIDE GAS SUPPLY MUST BE SHUT OFF AT THE GAS SUPPLY CONTAINERS(S) AND THE CARBON DIOXIDE GAS IN THE SYSTEM MUST BE COMPLETELY EXHAUSTED BEFORE SERVICING THE EQUIPMENT.

DO NOT DISCARD THIS INSTRUCTION BOOK UPON COMPLETION OF INSTALLATION. INFORMATION PROVIDED IS ESSENTIAL TO PROPER AND SAFE OPERATION AND MAINTENANCE.

VERY IMPORTANT SAFETY PRECAUTIONS - CARBON DIOXIDE (CONT'D)

ADDITIONAL OR REPLACEMENT COPIES OF THIS INSTRUCTION BOOK ARE AVAILABLE FROM:

Evoqua Water Technologies
725 Wooten Road
Colorado Springs, CO 80915
Phone: (800) 524-6324

NOTE

Minor part number changes may be incorporated into Evoqua Water Technologies products from time to time that are not immediately reflected in the instruction book. If such a change apparently has been made in your equipment and does not appear to be reflected in your instruction book, contact your local Evoqua Water Technologies sales office for information.

Please include the equipment serial number in all correspondence. It is essential for effective communication and proper equipment identification.

VERY IMPORTANT SAFETY PRECAUTIONS - SULFUR DIOXIDE

This and the following pages titled "Very Important Safety Precautions" provide, in brief, information of urgent importance relative to safety in the installation, operation, and maintenance of this equipment.

WARNING

TO AVOID POSSIBLE SEVERE PERSONAL INJURY OR EQUIPMENT DAMAGE, OBSERVE THE FOLLOWING:

THIS EQUIPMENT SHOULD BE INSTALLED, OPERATED, AND SERVICED ONLY BY TRAINED, QUALIFIED PERSONNEL WHO ARE THOROUGHLY FAMILIAR WITH THE ENTIRE CONTENTS OF THIS INSTRUCTION BOOK AND THE SULFUR DIOXIDE GAS HANDLING MANUAL.

EXPOSURE TO SULFUR DIOXIDE GAS IN LOW CONCENTRATION PRODUCES AN IRRITATING EFFECT ON THE MUCOUS MEMBRANES OF THE EYES, NOSE, THROAT, AND LUNGS. EXPOSURE TO HIGHER CONCENTRATION PRODUCES A SUFFOCATING EFFECT.

DO NOT TOLERATE ANY SULFUR DIOXIDE LEAKS. SULFUR DIOXIDE LEAKS NEVER GET BETTER. SULFUR DIOXIDE LEAKS ALWAYS GET PROGRESSIVELY WORSE IF THEY ARE NOT PROMPTLY CORRECTED. IT IS RECOMMENDED PRACTICE TO HAVE AN APPROVED GAS MASK AVAILABLE WHEN MAKING LEAK CHECKS.

AS SOON AS THERE IS ANY INDICATION OF THE PRESENCE OF SULFUR DIOXIDE IN THE AIR, TAKE IMMEDIATE STEPS TO CORRECT THE CONDITION.

IMPORTANT INFORMATION RELATED TO SAFETY OF SULFUR DIOXIDE EQUIPMENT INSTALLATIONS IS PROVIDED IN THE SULFUR DIOXIDE GAS HANDLING MANUAL. IN THE INTEREST OF SAFE OPERATIONS, AND TO AVOID THE POSSIBILITY OF PERSONAL INJURY, THIS INFORMATION MUST BE READ, UNDERSTOOD, AND PRACTICED BY EQUIPMENT OPERATORS AND THEIR SUPERVISORS.

AT TIME OF INITIAL INSTALLATION, WHEN SULFUR DIOXIDE SUPPLY LINES HAVE BEEN DISCONNECTED FOR ANY REASON, AND ON A ROUTINE DAILY BASIS, THOROUGHLY CHECK ALL JOINTS, CONNECTIONS, AND EQUIPMENT FOR POSSIBLE LEAKS, AND IMMEDIATELY CORRECT ANY THAT MAY BE FOUND.

WHEN ANY CONNECTION IS BROKEN EVEN FOR A SHORT TIME, IMMEDIATELY PLUG THE RESULTANT OPENINGS WITH A RUBBER STOPPER OR EQUIVALENT TO PREVENT THE ENTRANCE OF MOISTURE. MOISTURE MUST BE EXCLUDED FROM ANY PART OF THE EQUIPMENT THAT IS NORMALLY EXPOSED TO DRY SULFUR DIOXIDE ONLY. WHILE DRY SULFUR DIOXIDE IS NON-CORROSIVE, MOIST SULFUR DIOXIDE IS EXTREMELY CORROSIVE TO MANY COMMON METALS, SUCH AS BRASS, COPPER, OR STEEL.

THE TWO MOST COMMON CAUSES OF SULFUR DIOXIDE PIPING LEAKS ARE:

1. RE-USE OF GASKETS. THIS SHOULD NEVER BE DONE. ALWAYS HAVE AN ADEQUATE SUPPLY ON HAND AND ALWAYS USE NEW GASKETS OF THE CORRECT MATERIAL AND SIZE AS IDENTIFIED ON THE EQUIPMENT PARTS DRAWINGS.
2. IMPROPERLY MADE-UP THREADED PIPE JOINTS. JOINTS SHOULD BE MADE UP USING A SUITABLE THREAD DOPE OR FLUOROCARBON PLASTIC TAPE.

VERY IMPORTANT SAFETY PRECAUTIONS - SULFUR DIOXIDE (CONT'D)

USE ONLY EVOQUA WATER TECHNOLOGIES LISTED PARTS, EXCEPT FOR THOSE COMMERCIALY AVAILABLE PARTS THAT ARE IDENTIFIED BY COMPLETE DESCRIPTION ON PARTS LIST. THE USE OF UNLISTED PARTS CAN RESULT IN EQUIPMENT MALFUNCTIONS, AND CAUSE POSSIBLE SEVERE PERSONAL INJURY.

EXCEPT IN CASES OF LEAK DETECTION OR CALIBRATION ADJUSTMENTS, THE SULFUR DIOXIDE GAS SUPPLY MUST BE SHUT OFF AT THE GAS SUPPLY CONTAINER(S) AND THE SULFUR DIOXIDE GAS IN THE SYSTEM MUST BE COMPLETELY EXHAUSTED BEFORE SERVICING THE EQUIPMENT.

DO NOT DISCARD THIS INSTRUCTION BOOK UPON COMPLETION OF INSTALLATION. INFORMATION PROVIDED IS ESSENTIAL TO PROPER AND SAFE OPERATION AND MAINTENANCE.

ADDITIONAL OR REPLACEMENT COPIES OF THIS INSTRUCTION BOOK ARE AVAILABLE FROM:

Evoqua Water Technologies
725 Wooten Road
Colorado Springs, CO 80915
Phone: (800) 524-6324

NOTE

Minor part number changes may be incorporated into Evoqua Water Technologies products from time to time that are not immediately reflected in the instruction book. If such a change apparently has been made in your equipment and does not appear to be reflected in your instruction book, contact your local Evoqua Water Technologies sales office for information.

Please include the equipment serial number in all correspondence. It is essential for effective communication and proper equipment identification.

VERY IMPORTANT SAFETY PRECAUTIONS - CHLORINE

This and the following pages titled "Very Important Safety Precautions" provide, in brief, information of urgent importance relative to safety in the installation, operation, and maintenance of this equipment.

WARNING

TO AVOID POSSIBLE SEVERE PERSONAL INJURY OR EQUIPMENT DAMAGE, OBSERVE THE FOLLOWING:

THIS EQUIPMENT SHOULD BE INSTALLED, OPERATED, AND SERVICE ONLY BY TRAINED, QUALIFIED PERSONNEL WHO ARE THOROUGHLY FAMILIAR WITH THE ENTIRE CONTENTS OF THIS INSTRUCTION BOOK AND THE CHLORINE GAS HANDLING MANUAL.

CHLORINE GAS IS A RESPIRATORY IRRITANT. EXPOSURE TO CHLORINE GAS IN SUFFICIENT CONCENTRATION PRODUCES IRRITATION OF THE MUCOUS MEMBRANES, THE RESPIRATORY SYSTEM, AND THE SKIN. IN EXTREME CASES, SUFFOCATION AND DEATH CAN OCCUR.

WHEN CHANGING CHLORINE CYLINDERS, IT IS RECOMMENDED PRACTICE TO HAVE AN APPROVED GAS MASK AVAILABLE THAT YOU HAVE BEEN TRAINED TO USE AND YOU MUST BE COMPLETELY FAMILIAR WITH YOUR LOCAL PLANT OPERATING AND EMERGENCY PROCEDURES AND CHLORINE INSTITUTE RECOMMENDED EMERGENCY PROCEDURES.

DO NOT TOLERATE ANY CHLORINE LEAKS. CHLORINE LEAKS NEVER GET BETTER. CHLORINE LEAKS ALWAYS GET PROGRESSIVELY WORSE IF THEY ARE NOT PROMPTLY CORRECTED. IT IS RECOMMENDED PRACTICE TO HAVE AN APPROVED GAS MASK AVAILABLE WHEN MAKING LEAK CHECKS.

AS SOON AS THERE IS ANY INDICATION OF CHLORINE IN THE AIR, TAKE IMMEDIATE STEPS TO CORRECT THE CONDITION.

IMPORTANT INFORMATION RELATED TO SAFETY OF CHLORINATION EQUIPMENT INSTALLATION IS PROVIDED IN THE CHLORINE GAS HANDLING MANUAL. IN THE INTEREST OF SAFE OPERATION, THIS INFORMATION MUST BE READ, UNDERSTOOD, AND PRACTICED BY EQUIPMENT OPERATORS AND THEIR SUPERVISORS.

AT TIME OF INITIAL INSTALLATION, WHEN CHLORINE SUPPLY LINES HAVE BEEN DISCONNECTED FOR ANY REASON AND ON A ROUTINE DAILY BASIS, THOROUGHLY CHECK ALL JOINTS, CONNECTIONS, AND EQUIPMENT FOR POSSIBLE CHLORINE LEAKS AND IMMEDIATELY CORRECT ANY THAT MAY BE FOUND.

WHEN ANY CONNECTION IS BROKEN EVEN FOR A SHORT TIME, IMMEDIATELY PLUG THE RESULTANT OPENINGS WITH A RUBBER STOPPER OR EQUIVALENT TO PREVENT THE ENTRANCE OF MOISTURE. MOISTURE MUST BE EXCLUDED FROM ANY PART OF THE EQUIPMENT THAT IS NORMALLY EXPOSED TO DRY CHLORINE ONLY. WHILE DRY CHLORINE IS NON-CORROSIVE, MOIST CHLORINE IS EXTREMELY CORROSIVE TO COMMON METALS, SUCH AS BRASS OR STEEL.

VERY IMPORTANT SAFETY PRECAUTIONS - CHLORINE (CONT'D)

THE TWO MOST COMMON CAUSES OF CHLORINE PIPING LEAKS ARE:

1. RE-USE OF GASKETS. THIS SHOULD NEVER BE DONE. ALWAYS HAVE AN ADEQUATE SUPPLY ON HAND AND ALWAYS USE NEW GASKETS OF THE CORRECT MATERIAL AND SIZE AS IDENTIFIED ON THE EQUIPMENT PARTS DRAWING.
2. IMPROPERLY MADE-UP THREADED PIPE JOINTS. SEE CHLORINE GAS HANDLING MANUAL FOR RECOMMENDED PROCEDURE.

EXCEPT IN CASES OF LEAK DETECTION OR CALIBRATION ADJUSTMENTS, THE CHLORINE GAS SUPPLY MUST BE SHUT OFF AT THE GAS SUPPLY CONTAINERS AND THE CHLORINE GAS IN THE SYSTEM EXHAUSTED BEFORE SERVICING THE EQUIPMENT.

USE ONLY EVOQUA WATER TECHNOLOGIES LISTED PARTS, EXCEPT FOR COMMERCIALY AVAILABLE PARTS AS IDENTIFIED ON THE PARTS LIST. THE USE OF UNLISTED PARTS CAN RESULT IN EQUIPMENT MALFUNCTIONS HAVE HAZARDOUS CONSEQUENCES.

DO NOT DISCARD THIS INSTRUCTION BOOK UPON COMPLETION OF INSTALLATION. INFORMATION PROVIDED IS ESSENTIAL TO PROPER AND SAFE OPERATION AND MAINTENANCE.

ADDITIONAL OR REPLACEMENT COPIES OF THIS INSTRUCTION BOOK ARE AVAILABLE FROM:

Evoqua Water Technologies
725 Wooten Road
Colorado Springs, CO 80915
Phone: (800) 524-6324

NOTE

Minor part number changes may be incorporated into Evoqua Water Technologies products from time to time that are not immediately reflected in the instruction book. If such a change apparently has been made in your equipment and does not appear to be reflected in your instruction book, contact your local Evoqua Water Technologies sales office for information.

Please include the equipment serial number in all correspondence. It is essential for effective communication and proper equipment identification.

FLEXIBLE CONNECTION REPLACEMENT

VERY IMPORTANT MAINTENANCE AND SAFETY INFORMATION

YOUR ATTENTION IS DIRECTED TO THE CHLORINE INSTITUTE'S
RECOMMENDATION* THAT ---

FLEXIBLE METAL TUBING CONNECTIONS USED TO CONNECT CHLORINE SUPPLY CYLINDERS TO PIPING SYSTEMS "SHOULD BE REPLACED WHENEVER THERE IS SIGN OF DETERIORATION BUT, IN ANY EVENT, AT INTERVALS NO LESS THAN ANNUALLY."

SIMILAR RECOMMENDATIONS APPLY FOR OTHER GASSES.

This recommendation recognizes the potential for mechanical damage to these connections in normal use, as well as the possibility of reduced mechanical strength resulting from the corrosive effects of damp air entering the tubing during the process of changing cylinders. Either of these conditions can be difficult to detect and carries the potential for breakage and resultant chlorine (or other gas) leakage. A timely replacement program can minimize this potential.

Deterioration exists if a salmon-pink color develops on the end fittings (de-zincification due to a minute leak), if dents or kinks are present (which weaken the tubing), or if the tubing "squeaks" when it is handled (a sure sign of internal stress corrosion).

FOR YOUR CONVENIENCE, EVOQUA WATER TECHNOLOGIES MAINTAINS A COMPLETE STOCK OF STANDARD FLEXIBLE CONNECTIONS (TYPICAL UNITS ARE ILLUSTRATED ON DRAWING 50.150.07.021) AND IS PREPARED TO RESPOND TO YOUR PURCHASE ORDER WITH PROMPT SHIPMENT.

*Refer to paragraph titled CONNECTIONS in the Chlorine Handling Manual attached to the rear of this instruction book — "Connections should be replaced whenever there is sign of deterioration but, in any event, at intervals no less than annually."



PROTECT YOUR EQUIPMENT INVESTMENT

MINIMIZE DOWNTIME

**ORDER A PREVENTIVE MAINTENANCE KIT NOW ...
KEEP ONE ON HAND**

Quality Equipment	+	Preventive Maintenance	=	Dependable Operation Minimum Downtime
------------------------------	----------	-----------------------------------	----------	--

There's no question about it.

Equipment that is properly maintained is dependable equipment.
It will give optimum performance with minimum unscheduled downtime.

Evoqua Water Technologies manufactures quality equipment designed for performance and reliability. Each product is carefully tested and inspected before shipment to ensure that it meets our high standards.

Our equipment is engineered for easy maintenance. To ensure maximum service life and minimize unscheduled repairs, we recommend a program of regular preventive maintenance, as described in the Service section of this book. To support this program, we developed standard parts kits. These kits can also be used for minor emergency repairs to minimize downtime.

We recommend that these kits be available in your stock at all times. When the complete kit or any of its parts are used, the kit should be replaced immediately.

Preventive maintenance kits may be ordered directly from the company that supplied your equipment, or they may be ordered directly from Evoqua Water Technologies. For ordering numbers, refer to the parts list at the rear of this book.

**PREVENTIVE MAINTENANCE SCHEDULE
AND RECORD OF PERFORMANCE**

This equipment should receive preventive maintenance on a one (1) year cycle.* It is recommended that the following table be used to plan, schedule, and record this important work.

Date of Installation	
-----------------------------	--

Preventive Maintenance Log	
Schedule Date	Date Performed

***NOTE:** This is the recommended cycle. Your local operating conditions may call for more frequent preventive maintenance.



PROTECT YOUR EQUIPMENT INVESTMENT

MINIMIZE DOWNTIME

**ORDER A PREVENTIVE MAINTENANCE KIT NOW ...
KEEP ONE ON HAND**

REGIONAL OFFICES**INSTALLATION, OPERATION, MAINTENANCE, AND SERVICE INFORMATION**

Direct any questions concerning this equipment that are not answered in the instruction book to the Reseller from whom the equipment was purchased. If the equipment was purchased directly from Evoqua Water Technologies, Colorado Springs, CO contact the office indicated below.

UNITED STATES

725 Wooten Road
Colorado Springs, CO 80915
TEL: (800) 524-6324

CANADA

If the equipment was purchased directly from Evoqua Water Technologies, Canada, contact the nearest office indicated below.

ONTARIO

Evoqua Water Technologies Ltd.
2045 Drew Road
Mississauga, Ontario
L5S 1S4
(905) 944-2800

QUEBEC

Evoqua Technologies des Eaux Itée
505 Levy Street
St. Laurent, Quebec
H4R 2N9
(450) 582-4266

VACUUM REGULATOR-CHECK UNIT - 510 M/S

Identify maximum capacity by housing: 210 or 510?

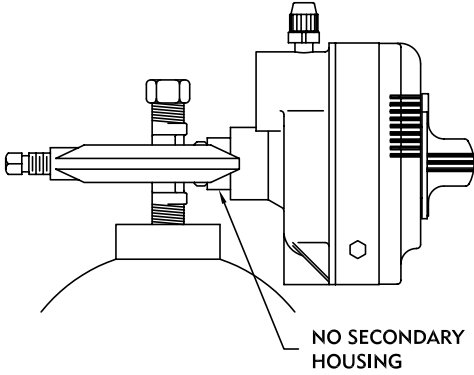

210
NO SECONDARY HOUSING

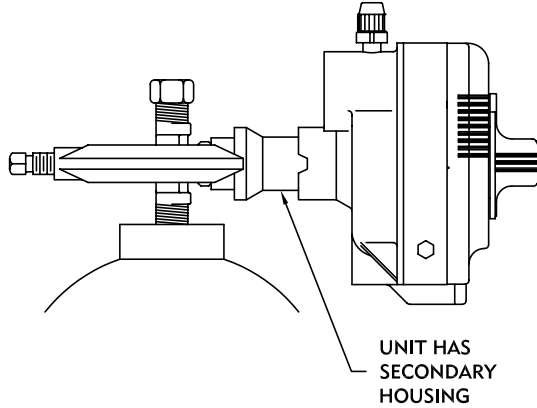

510
WITH SECONDARY HOUSING

Identify switchover by cover icons: Auto or Standard?

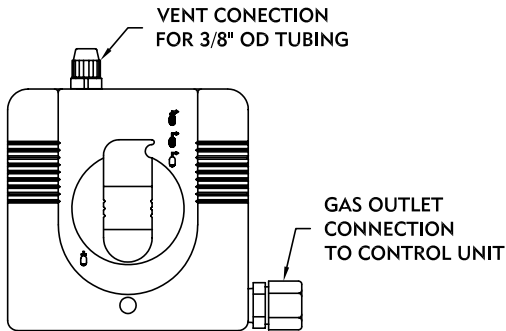

AUTO SWITCHOVER

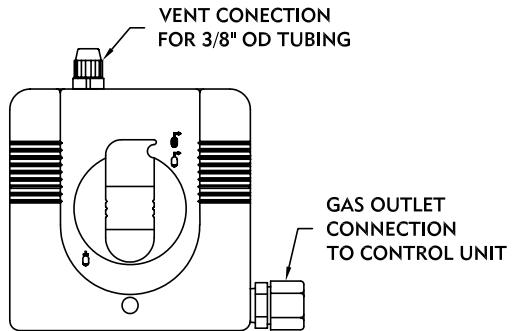

STANDARD

VACUUM REGULATOR SWITCHOVER - IDENTIFICATION

25.210.150.010

ISSUE 1 12-07

1 TECHNICAL DATA

Feed Range	
Chlorine	0 to 500 lb/24 hr
Sulfur Dioxide	0 to 475 lb/24 hr
Carbon Dioxide	0 to 390 lb/24 hr
Electrical Requirements (if heater is used)	115 VAC, 50 or 60 Hz to 220 VAC, 50 or 60 Hz single phase
Gas Supply Pressure	20 to 220 psig
Regulated Vacuum	10 to 32 inches of water
Standby to Operating Vacuum Level	42 to 52 inches of water
Operating to Empty Vacuum Level	38 to 40 inches of water
Weight	5.0 lbs



WARNING: THIS EQUIPMENT IS SUITABLE FOR USE ONLY WITH THE GASES SPECIFIED. DO NOT USE WITH OTHER GASES. SUCH USE CAN RESULT IN MALFUNCTION OR FAILURE OF VARIOUS COMPONENTS, HAVING HAZARDOUS CONSEQUENCES.

2 INSTALLATION

The general physical requirements of the installation are shown on the Typical Installation and Installation Piping drawings. Locate the equipment so that the necessary gas supply can be properly connected. Ready access to the equipment for operation, routine maintenance, and service is required.

Piping for chlorine (or sulfur dioxide) supply, where the chlorine (or sulfur dioxide) is under pressure, should conform to Chlorine Institute (or Compressed Gas Association) recommendations. Plastic tubing and pipe are not recommended and should not be used.

When threaded joints are used, take extreme care to obtain clean, sharp threads. TFE tape may be used to seal threads of non-gasketed joints. When TFE tape is used on a remade joint, remove all remnants of old tape and apply new tape to threads. Apply a single turn of tape plus some overlap stretched so that tape follows the thread contours. Wrap the tape in the same direction as the threads. TFE tape provides a durable, yet easily removed thread seal, especially advantageous if a joint is to be broken in the future. For permanent joints, litharge and glycerine is recommended as the sealant.

See the installation drawings that follow and be sure they are understood before installation is started. See the parts drawings for identification and location of parts and their part numbers.

2.1 Gas Supply From Cylinder

When mounted on a gas supply cylinder, the vacuum regulator-check unit is connected to the cylinder valve by a yoke. The cylinder must be vertical with the cylinder valve on top.



WARNING: TO AVOID GAS LEAKAGE AND POSSIBLE SEVERE PERSONAL INJURY OR EQUIPMENT DAMAGE, ALWAYS USE A NEW LEAD GASKET WHEN INSTALLING A VACUUM REGULATOR AND EACH TIME A SUPPLY CYLINDER IS CHANGED. NEVER REUSE GASKETS.

If the system is composed of just one vacuum regulator-check unit, when the cylinder to which it is attached is exhausted, a full cylinder is put in place and the unit is reconnected. If the system is composed of two automatic switchover units, one unit will feed gas on demand until its cylinder is exhausted, at which time the system will automatically switch to the second full cylinder. The exhausted cylinder may then be replaced with a full one when convenient. Upon exhaustion of the second cylinder, the switchover process will reverse itself to the newly placed full cylinder.



CAUTION: When a vacuum regulator is connected to a gas tank manifold, ensure that the manifold does not run above the unit so as to allow reliquefied chlorine or sulfur dioxide to settle in the unit. Residue, if allowed to accumulate, may gum up and obstruct proper operation of the unit. If necessary, install a trap or drip leg to collect any liquid chlorine or sulfur dioxide.

2.2 Gas Supply From a Ton Container

If the source of gas supply is to be a ton container, a vacuum regulator-check unit equipped with a drip leg must be used. See Dwg. 25.510.110.010.



WARNING: THIS UNIT MAY CONTAIN LIQUID OR GAS UNDER HIGH PRESSURE. TO AVOID POSSIBLE SEVERE PERSONAL INJURY OR DAMAGE TO EQUIPMENT, CLOSE SUPPLY CONTAINER VALVE AND EVACUATE COMPLETE SYSTEM BEFORE DISCONNECTING SUPPLY OR DISASSEMBLING UNIT. TO AVOID POSSIBLE SEVERE PERSONAL INJURY OR DAMAGE TO EQUIPMENT, ON TON CONTAINERS THE UNIT MUST BE CONNECTED TO THE UPPER VALVE, WHICH DISCHARGES GAS, AND NOT TO THE LOWER VALVE, WHICH DISCHARGES LIQUID.

2.2.1 Ton Container Kit / Installation Instructions (see Dwgs. 25.510.001.010 and 25.510.000.010A & B)

- a. Remove the nipple assembly from the vacuum regulator.



- b. Remove the yoke assembly from the vacuum regulator.



- c. Place the collar (7) onto the vacuum regulator nipple assembly.



Note: The two posts on the collar should face the vacuum regulator.

There are two spacers (10) that go onto the posts. If you have a 500 ppd regulator the narrow side of the spacer should go against the collar. If you have a 200 ppd regulator the widest side of the spacer should go against the collar.

- d. Screw the nipple assembly with the collar and spacers into the vacuum regulator. Set the vacuum regulator aside.



- e. Place the yoke that was removed from the regulator in step b onto the Inlet Nipple (12).



- f. Apply sealant to the Inlet Nipple (12) and screw it into the body (1).



- g. Use the 4 bolts and washers included (8 and 9) and bolt the collar (7) already connected to the vacuum regulator to the body (1).

Note: Place a lead washer in between the vacuum regulator and the body.



- h. Follow the installation and leak testing procedures in the vacuum regulator instruction manual.



2.3 Checking For Leaks (see Dwg. 25.510.180.010)

A bottle of aqueous ammonia is available for checking leakage of chlorine (or sulfur dioxide) gas at joints, valves, etc.

Carbon dioxide leaks may be detected by the application of soapy water to suspected areas or by means of commercially available leak detectors. Consult your gas supplier for additional information.



WARNING: TO AVOID POSSIBLE SEVERE PERSONAL INJURY, WHEN MAKING LEAK CHECKS IT IS RECOMMENDED PRACTICE TO HAVE AN APPROVED GAS MASK AVAILABLE THAT YOU HAVE BEEN TRAINED TO USE.

NOTE: For chlorine (or sulfur dioxide) leak testing, use Wallace & Tiernan® U409 or commercial 26° Baume' aqua ammonia. Household ammonia is not strong enough.

After the vacuum regulator-check unit(s) are in place and before the gas tubing to the control unit is installed, check for gas leaks as follows:

- a. Turn the vacuum regulator knob to the OFF position (by pushing the knob down and rotating clockwise).
- b. Open the gas supply container valve not more than approximately 1/8 of a turn.



WARNING: TO AVOID POSSIBLE SEVERE PERSONAL INJURY OR EQUIPMENT DAMAGE, THE GAS SUPPLY CONTAINER VALVE MUST NOT BE OPENED MORE THAN APPROXIMATELY 1/8 TURN DURING LEAK CHECK. THIS WILL SUPPLY SUFFICIENT GAS TO LEAK CHECK THE EQUIPMENT AND ALSO CAN BE TURNED OFF QUICKLY IN THE EVENT OF A GAS LEAK.

- c. Using a dauber moistened with aqueous ammonia (for Cl₂ or SO₂ system), a leak detector, or soapy water (for CO₂ systems), apply the appropriate leak indicator to the yoke-gasketed joint, all pipe threaded joints including any plugs, and the opening of the plastic discharge fitting. A leak will be indicated by a white cloud for chlorine or sulfur dioxide. A carbon dioxide leak will be indicated by bubbles in the soapy water or by the leak detecting device.



WARNING: TO AVOID POSSIBLE SEVERE PERSONAL INJURY OR EQUIPMENT DAMAGE, DO NOT TOLERATE ANY LEAKS. LEAKS ALWAYS GET PROGRESSIVELY WORSE AND MUST BE CORRECTED PROMPTLY.

- d. If leaks are detected, immediately close the supply container valve and take appropriate corrective steps. Correct leaks as indicated by the nature of the leak (tightening of gasketed joints or screws, new gaskets, pipe thread sealant, etc.).
- e. Repeat the leak check procedure until satisfied that there are no leaks.

2.4 Changing Cylinders (see Dwg. 25.510.180.010)



WARNING: PRIOR TO PERFORMING THIS OPERATION YOU MUST BE COMPLETELY FAMILIAR WITH THE APPROPRIATE GAS MANUAL AND YOUR LOCAL PLANT OPERATING AND EMERGENCY PROCEDURES. TO AVOID POSSIBLE SEVERE PERSONAL INJURY OR DAMAGE TO EQUIPMENT, CYLINDERS MUST BE SECURED IN SUCH A MANNER (E.G., CHAIN) AS TO PREVENT THEIR BEING KNOCKED OVER.

When a cylinder is exhausted as shown by the color indicator on the front of the vacuum regulator turning to red or by a scale showing depletion of contents, place a full cylinder ready for service. If the gas feeder is operating, the injector need not be shut off. If the system has two vacuum regulator-check units for automatic switchover, the in-use unit need not be shut off. Proceed as follows:

- a. Bring a full cylinder to the point of use.
- b. Close the supply cylinder valve on the exhausted cylinder.
- c. Turn the vacuum regulator-check unit knob all the way to OFF.



CAUTION: When any connection is broken even for a short time, immediately plug the resultant openings with a rubber stopper or equivalent to prevent the entrance of moisture.

- d. Disconnect the empty cylinder from the supply line. If the vacuum regulator-check unit is mounted directly on the cylinder, loosen the yoke screw and remove the vacuum regulator-check unit from the empty cylinder. Rest the vacuum regulator-check unit on any support surface or hang from a hook through the yoke.



CAUTION: Do not permit the vacuum regulator to hang by the tubing. Unsupported, it may cause kinking or loosening of tubing at the connections, which, in time, may cause a leak.

- e. Release the chain and move the empty cylinder aside.
- f. Move the full cylinder into place and secure the restraining chain. Check that the cylinder valve packing nut has not worked loose. Tighten if necessary.
- g. Remove the old gasket from the supply line connection or vacuum regulator-check unit inlet nipple and discard it. Replace it with a new lead gasket.
- h. Position the vacuum regulator-check unit on the cylinder valve and tighten the yoke screw securely.
- i. Check for leaks following procedure in paragraph 2.3, Checking for Leaks.
- j. Check the gasket joint and packing nut for leaks. Correct as indicated.



WARNING: TO AVOID POSSIBLE SEVERE PERSONAL INJURY OR EQUIPMENT DAMAGE, DO NOT TOLERATE ANY LEAKS. LEAKS ALWAYS GET PROGRESSIVELY WORSE AND MUST BE CORRECTED PROMPTLY.

- k. Turn the cylinder valve so that it is open approximately one turn.
- l. After correcting any leaks, turn the vacuum regulator-check unit knob fully to OPERATING or STANDBY.
- m. Replace the empty cylinder valve cap and hood, tear tag (designating empty cylinder), and move to the storage area for empty cylinders.

2.5 Vent

As shown on the Typical Installation drawings, a vent line is required from the pressure relief valve to a treatment system or a point outside the building where an occasional odor of chlorine or sulfur dioxide will not be objectionable. The proper installation of this line is important. The gradient of the line must be continuous, without traps. Point the atmospheric end down and screen it against the entrance of foreign materials. Where traps are unavoidable or a down gradient is not possible, provisions for condensate removal must be installed at all low points (drip leg). Suitable support for the vent is required throughout its entire length.



WARNING: THE STANDBY PRESSURE RELIEF VALVE MUST BE VENTED TO A TREATMENT SYSTEM OR OUTSIDE ATMOSPHERE. THE VENT LINE MUST TERMINATE IN AN AREA WHERE GAS FUMES CANNOT CAUSE INJURY TO PERSONNEL OR DAMAGE TO EQUIPMENT. DO NOT TERMINATE THE VENT LINE AT A LOCATION ROUTINELY USED BY PERSONNEL, SUCH AS WORK AREAS OR PATHWAYS, NOR NEAR WINDOWS OR VENTILATION SYSTEM INTAKES.

3 OPERATION

The vacuum regulator-check unit regulates the supply of gas to the control unit. Refer to the chlorinator or other gas feeder instruction book for operating instructions and important precautions related to that equipment.



WARNING: TO AVOID POSSIBLE SEVERE PERSONAL INJURY OR EQUIPMENT DAMAGE, FOR LONG-TERM SHUTDOWN, TO ENSURE COMPLETE SHUT-OFF OF THE GAS SUPPLY, THE GAS SUPPLY CONTAINER VALVES MUST BE CLOSED IN ADDITION TO THE VACUUM REGULATOR.

3.1 Theory of Operation (see Dwg. 25.510.180.010)

Gas under pressure enters the vacuum regulator. The gas pressure is reduced to less than atmospheric pressure as the gas passes through two valves that will not open unless the minimum operating vacuum is produced.

If the first valve passes gas when a vacuum is not present, the second valve will remain closed and contain the pressure in the inlet cartridge, which is designed to contain full gas supply container pressure. In the extremely unlikely event that the second valve also passes gas, a pressure relief valve will permit this gas to pass out the vent. For this reason the vent line must be run to a treatment system or outside atmosphere. Automatic switchover capability is provided (when ordered) by two vacuum regulator-check units fitted with mechanical detents. One vacuum regulator-check unit feeds gas until the supply to which it is connected is exhausted. The resulting rise of vacuum to higher than normal provides sufficient force to unlatch the second unit, which then takes over the gas supply function.

4 SERVICE

Maintenance consists of two periodically performed operations.

- a. Periodic Cleaning to remove contaminants and deposits.
- b. Periodic Preventive Maintenance to disassemble, inspect, and accomplish recommended parts replacement. A kit of replacement parts required for the periodic maintenance of the vacuum regulator-check unit is available and is listed at the rear of this book.

**PROTECT YOUR EQUIPMENT INVESTMENT
MINIMIZE DOWNTIME
REORDER A PREVENTIVE MAINTENANCE KIT NOW
KEEP ONE ON HAND**

4.1 Periodic Cleaning

To ensure that all elements of your equipment are free of contaminants that can accumulate over a period of time, it is recommended that the following checks be made at the stated intervals. This will minimize unscheduled disruptions of service and maximize service life. Before starting work, ensure that the appropriate replacement parts and/or maintenance kit is on hand.

MAINTENACNE ITEMS	WHEN TO PERFORM
Stems and Spring in Vacuum Regulator	After 12,000 lbs. of gas have been fed

4.1.1 Cleaning Vacuum Regulator-Check Unit (see Dwg. 25.510.000.010)

The standard and automatic switchover units are both cleaned in the same manner.



WARNING: TO AVOID POSSIBLE SEVERE PERSONAL INJURY OR EQUIPMENT DAMAGE, SHUT OFF THE GAS SUPPLY CONTAINER VALVE. OPERATE THE CHLORINATOR OR GAS FEEDER TO REMOVE REMAINING GAS FROM THE UNIT; FOLLOW THE INSTRUCTIONS IN THE CHLORINATOR OR GAS FEEDER INSTRUCTION BOOK FOR COMPLETE REMOVAL OF GAS.

NOTE: It should not be necessary to disassemble and clean the operating shaft and lever assembly. If problems are encountered with this assembly, notify the Evoqua Water Technologies Technical Services department or your supplier.

- a. Unscrew union nut from regulator gas outlet connector and disconnect the discharge tubing from the vacuum regulator-check unit. Plug the tube with a rubber stopper to prevent entry of air and dampness while the vacuum regulator-check unit is being cleaned. Loosen union nut (27) from vent connection (26) and disconnect the vent tubing.
- b. Loosen yoke screw and remove the entire vacuum regulator-check unit to a location where the work is to be done. Cap the gas supply container valve outlet while not in use.
- c. Remove inlet nipple (34).
- d. Remove filter (40), screen (39), retainer (38), stem spring (37), and valve stem (36). Remove guide (47), spring (46), and stem (45) from pressure check housing (19).
- e. Hold the inlet nipple and seat assembly under hot running water (approximately 130-150°F) to soften and flush away deposits. If running hot water is not available pour hot water, as from a kettle, in the same manner. Using a detergent may help loosen stubborn deposits.



CAUTION: Do not scrape or damage the hole in the Teflon seat, as this could destroy the seat shape and stem seating surface

- f. Remove all traces of detergent and moisture from the parts before returning parts to service. Do not use heat on plastic parts.
- g. Clean the valve stems, springs, screen, retainer, and guide using hot water. A toothbrush is a useful scrubbing tool on these parts. Do not use a knife or scraper on the conical part of the valve stem. Use paper towels or a clean rag to wipe and dry the parts.
- h. Thoroughly dry all parts of the vacuum regulator-check unit before re-assembly and use. Incoming chlorine or sulfur dioxide combined with moisture produces a strong oxidizing solution that rapidly corrodes metal parts. Warming the parts is the most effective means of drying them. A simple and effective way of doing this is to rest the parts close to a lighted electric light bulb, such as a mechanic's service light, for about 15 minutes. Allow the parts to cool for comfortable handling and then proceed with assembly.
- i. Install stems with the cones toward the Teflon seats. Install the spring. Insert the retainer, screen, and guide. Lubricate O-ring (44) with Halocarbon grease and install the inlet nipple.
- j. Apply a few drops of oil where the yoke screw enters the clamp and a dab of grease on the yoke screw thread to facilitate clamping the gasket.

- k. Return the assembled vacuum regulator-check unit to the gas supply container valve on which it is to be used. Install a new filter and lead gasket on the inlet nipple and tighten the yoke screw securely.
- l. Turn the knob to OFF. Open the gas supply container valve not more than approximately 1/8 turn and make an all-around leak check.



WARNING: TO AVOID POSSIBLE SEVERE PERSONAL INJURY OR EQUIPMENT DAMAGE, DO NOT TOLERATE ANY LEAKS. AS SOON AS THERE IS ANY INDICATION OF A LEAK, TAKE IMMEDIATE STEPS TO CORRECT THE CONDITION.

- m. Remove the temporary plug from the discharge tubing and reconnect to the discharge fitting. Reconnect the vent tubing. Place the unit in service or on standby as desired.

4.2 Periodic Preventive Maintenance

To recondition any 500 lb/24 hour vacuum regulator-check unit at one-year intervals, obtain a Preventive Maintenance Kit and perform the procedures described in the instruction sheet supplied with the kit.

4.3 Switchover Level Verification

This switchover unit includes two P19865 (50) washers. They can be used to shift the vacuum level that triggers the switchover action. The switchover action should occur between 42 and 48 inches of water vacuum level. A low feed rate of 4 PPD must be used to accurately identify the switchover vacuum level. If the switchover vacuum level is below 42 inches of water add one or two of the P19865 (50) washers to the operating shaft assembly. Each washer increases vacuum by approximately three inches of water. See Dwgs. 25.510.000.020A & B.

To add the washers, push out the pin (16) from the operating shaft. Remove the spring (13) from the operating shaft (11). Place one or two P19865 (50) washers into the operating shaft (11). Place spring (13) back into the operating shaft (11). Realign the operating shaft (11), spring (13), pawl (14), lever (15) and push in pin (16).

5 IMPORTANT SAFETY INSTRUCTIONS FOR AUXILIARY CYLINDER VALVE

This valve operates under full cylinder pressure and its construction must be understood. See Dwg. 50.150.001.012 for the physical details of the valve.



WARNING: TO AVOID POSSIBLE SEVERE PERSONAL INJURY OR EQUIPMENT DAMAGE, DO NOT REMOVE THE PACKING NUT WHILE THE VALVE IS UNDER PRESSURE FOR ANY REASON.

If a new packing is required, proceed as follows:

- a. Close the main gas supply cylinder valve and relieve gas pressure in the line connected to the auxiliary cylinder valve by operating injector until the gas pressure gauge reads zero.
- b. Remove valve handle (9) from valve stem (5) and valve body (4) by rotating counterclockwise.
- c. Turn packing nut (8) clockwise to remove.

NOTE: The packing nut is equipped with a left-hand thread. Therefore, turning CW loosens while turning CCW tightens the packing nut.

- d. Remove plastic washer (7) and packing (6).
- e. Discard old packing and install new packing.
- f. Reassemble in reverse order. Check to be sure valve handle is engaged on both the valve stem (5) and the valve body (4) as follows:
 - (1) Seat valve stem (5) before the handle covers all the threads on the valve body (4).
 - (2) If the handle travels too far, remove it; push in the valve stem slightly; re-engage the handle; and close the valve.
 - (3) Readjust the valve stem as required so that about one thread on the valve body is exposed when the valve closes.
- g. Check for leaks. Refer to paragraph 2.3, Checking for Leaks.

To tighten the packing while the valve is under pressure, follow Step b. Then using a small wrench (not over six inches long to avoid damage to the threads) turn the packing nut (8) counterclockwise to tighten. Replace the valve handle (9).

WARNING/CAUTION LABELS

The following warning labels have been attached to the equipment.

AHS4646: HAZARDOUS GAS IS PRESENT IN THIS EQUIPMENT DURING NORMAL OPERATION. TO AVOID POSSIBLE SEVERE PERSONAL INJURY OR DAMAGE TO THE EQUIPMENT, READ THE EVOQUA WATER TECHNOLOGIES INSTRUCTION BOOK AND THE APPROPRIATE GAS MANUAL BEFORE CONNECTING THIS EQUIPMENT TO A SUPPLY OF GAS. OPERATION AND MAINTENANCE OF THIS EQUIPMENT MUST BE RESTRICTED TO TRAINED, QUALIFIED PERSONNEL WHO ARE COMPLETELY FAMILIAR WITH THESE INSTRUCTIONS.

AAA2496: THIS UNIT MAY CONTAIN LIQUID OR GAS UNDER HIGH PRESSURE. TO PREVENT POSSIBLE SEVERE PERSONAL INJURY OR DAMAGE TO EQUIPMENT CLOSE SUPPLY CONTAINER VALVE AND EVACUATE COMPLETE SYSTEM BEFORE DISCONNECTING SUPPLY OR DISASSEMBLING UNIT. SEE INSTRUCTION BOOK.

CAUTION LABEL

The following caution label has been attached to the equipment.

ADH4733: FOR CHLORINE, SULFUR DIOXIDE, OR CARBON DIOXIDE USE ONLY.

VACUUM REGULATOR-CHECK UNIT - 510 M/S

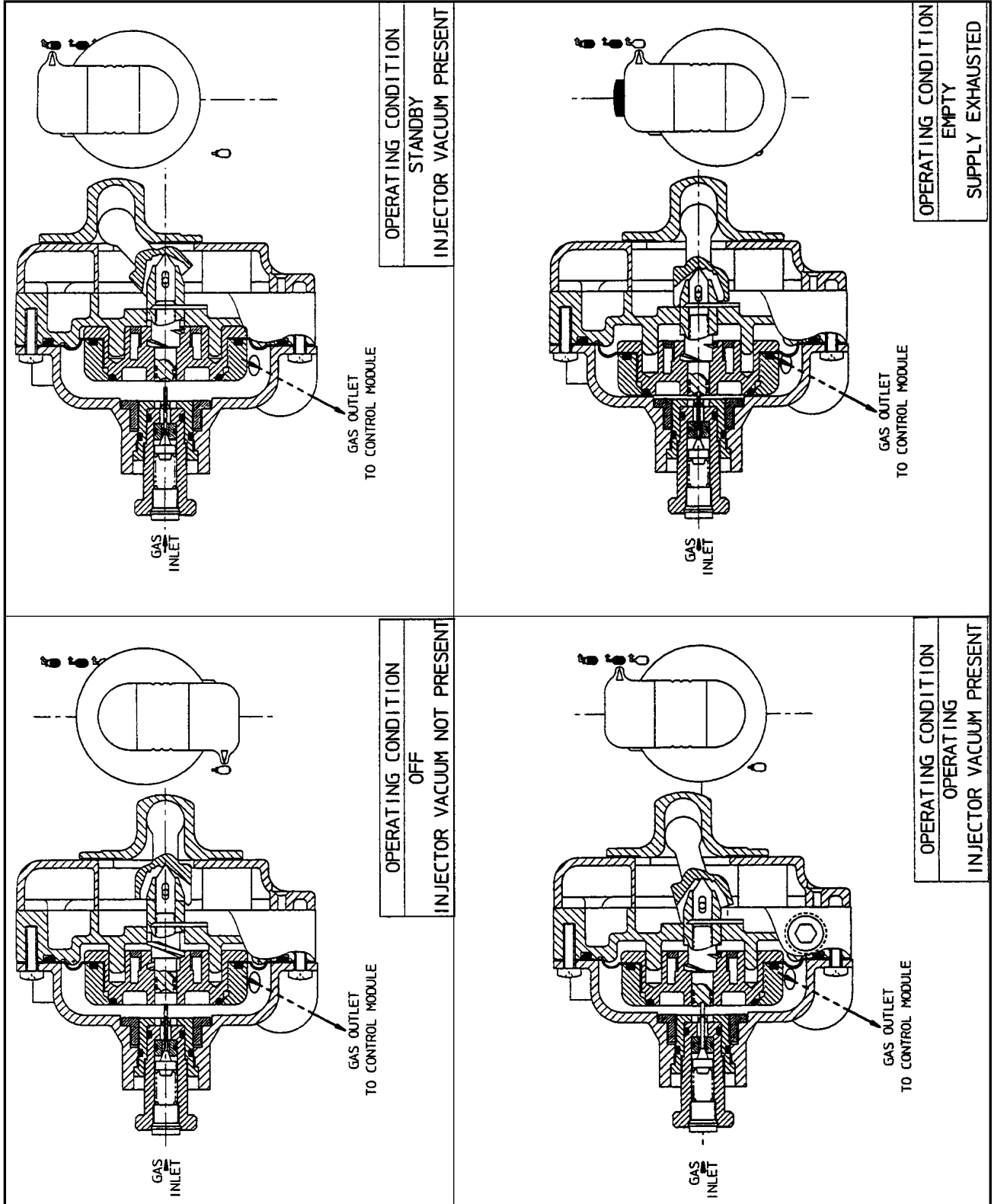

AUTOMATIC SWITCHOVER VACUUM REGULATOR - FLOW DIAGRAM

25.210.180.010

ISSUE 0 10-95

VACUUM REGULATOR-CHECK UNIT - 510 M/S

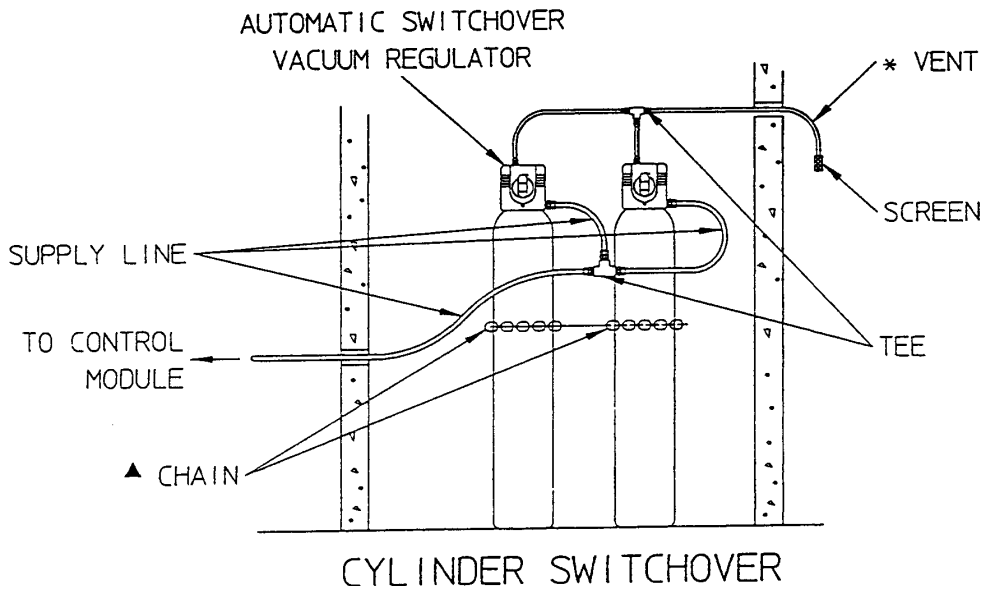
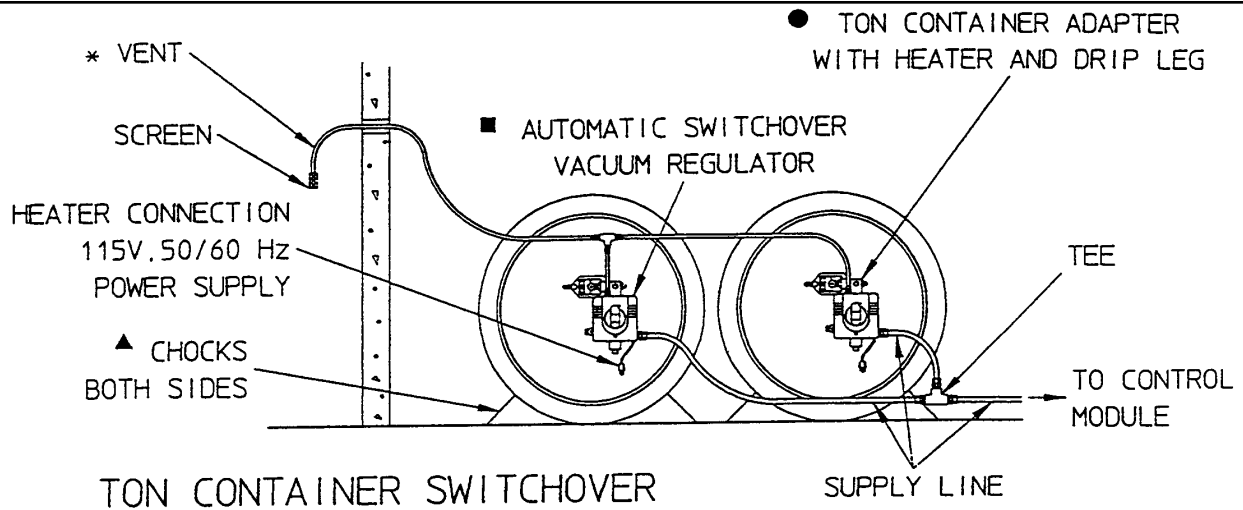

- WARNING:**
- TO AVOID POSSIBLE SEVERE PERSONAL INJURY OR EQUIPMENT DAMAGE, ON TON CONTAINERS THE UNIT MUST BE CONNECTED TO THE UPPER VALVE WHICH DISCHARGES GAS, NOT TO THE LOWER VALVE WHICH DISCHARGES LIQUID.
 - DRIP LEG MAY CONTAIN LIQUID OR GAS UNDER HIGH PRESSURE. TO AVOID POSSIBLE SEVERE PERSONAL INJURY OR EQUIPMENT DAMAGE, CLOSE CONTAINER VALVE AND EVACUATE COMPLETE SYSTEM BEFORE DISCONNECTING GAS SUPPLY CONTAINER OR DISASSEMBLING UNIT.
 - ▲ TO AVOID POSSIBLE SEVERE PERSONAL INJURY OR EQUIPMENT DAMAGE, SUPPLY CYLINDERS OR TON CONTAINERS MUST BE SECURED IN SUCH A MANNER (e.g., CHAIN OR CHOCKS) AS TO PREVENT THEIR BEING KNOCKED OVER OR ROLLED OUT OF PLACE.
 - * THE STANDBY PRESSURE RELIEF VALVE MUST BE VENTED TO A TREATMENT SYSTEM OR OUTSIDE ATMOSPHERE. THE VENT LINE MUST TERMINATE IN AN AREA WHERE GAS FUMES CANNOT CAUSE DAMAGE OR INJURY TO PERSONNEL. DO NOT TERMINATE THE VENT LINE AT A LOCATION ROUTINELY USED BY PERSONNEL, SUCH AS WORK AREAS OR PATHWAYS NOT NEAR WINDOWS OR VENTILATION SYSTEM INTAKES.

SUPPLY CONNECTIONS - TYPICAL INSTALLATION
Used in Remote Vacuum Gas Feed Equipment

25.510.110.010

ISSUE 0 10-95

VACUUM REGULATOR-CHECK UNIT - 510 M/S

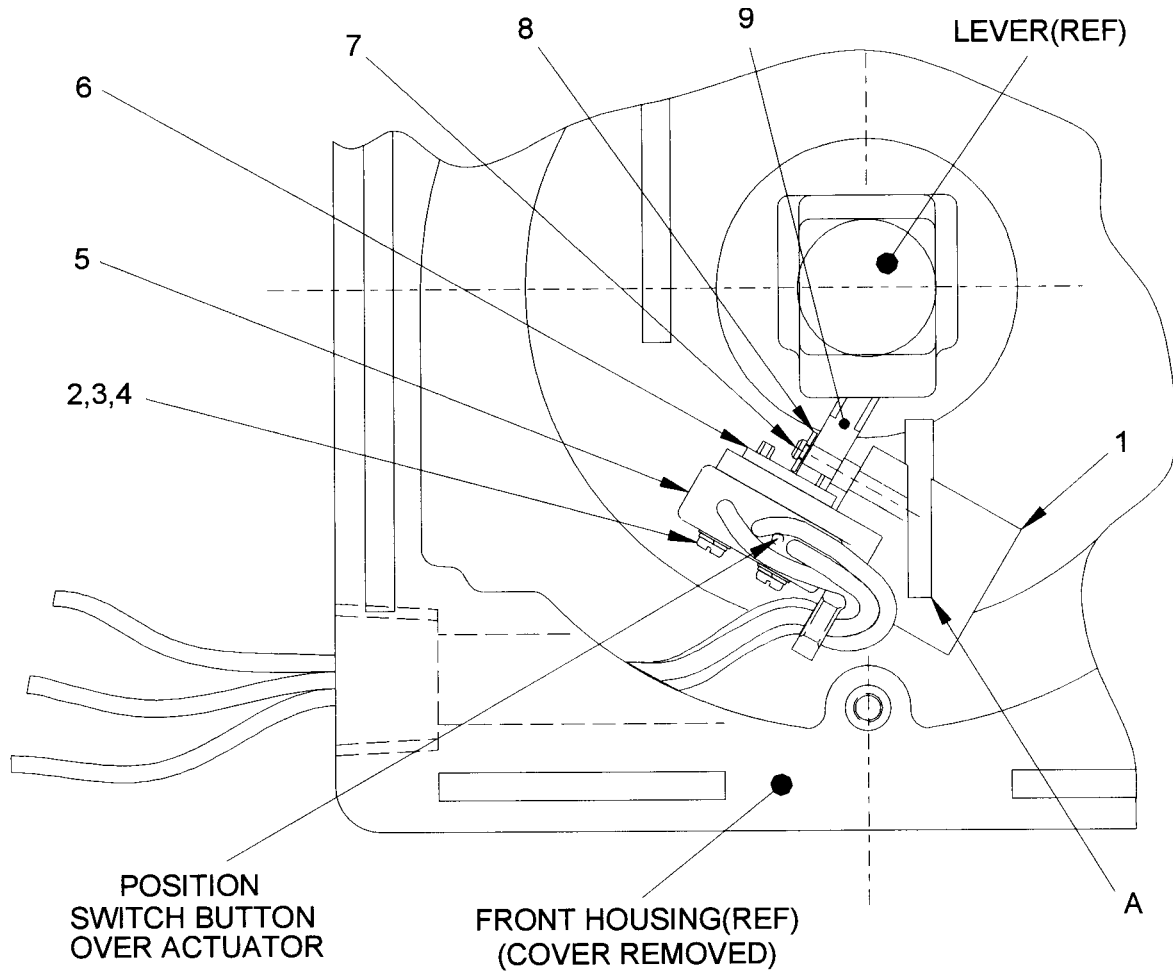

KEY NO.	PART NO.	QTY.	DESCRIPTION
1	APP3546	1	MOUNTING BRACKET
2	AAA1341	2	SCREW, M2 x 16
3	AAA2544	2	LOCKWASHER, M2
4	AAA2181	2	WASHER, M2
5	APS3481	1	MICRO SWITCH
6	AJC3485	1	RETAINER
7	AKG3489	1	PIVOT POST
8	AAA2547	1	CIRCLIP, M2.3
9	APP3993	1	ACTUATOR

ASSEMBLY PROCEDURE

1. CEMENT MOUNTING BRACKET (KEY NO.1) TO FRONT HOUSING AS SHOWN (AT "A"), USING PVC CEMENT.
2. LOOSEN SCREWS (KEY NO. 2).
3. OPERATE REGULATOR UNIT TO HIGH VACUUM (EMPTY).
4. ADJUST SWITCH TO SIGNAL HIGH VACUUM ALARM.
5. TIGHTEN SCREW.
6. REPEAT STEP 3 TO CHECK SWITCH.

WHEN ORDERING MATERIAL, ALWAYS SPECIFY MODEL AND SERIAL NUMBER OF APPARATUS.

AAA3704 VACUUM ALARM SWITCH - TYPICAL INSTALLATION

25.510.110.030

ISSUE 3 5-99

VACUUM REGULATOR-CHECK UNIT - 510 M/S

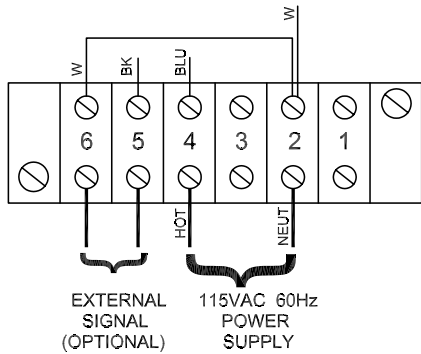

TERMINAL STRIP FURNISHED ONLY ON PANEL MOUNTED CENTRAL ALARM UNIT (U22551)

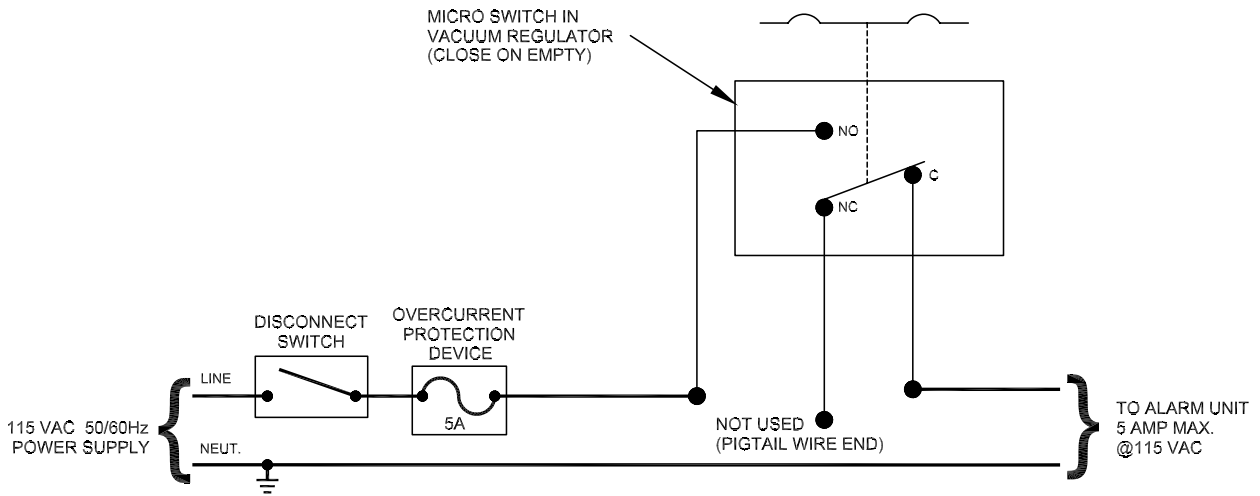
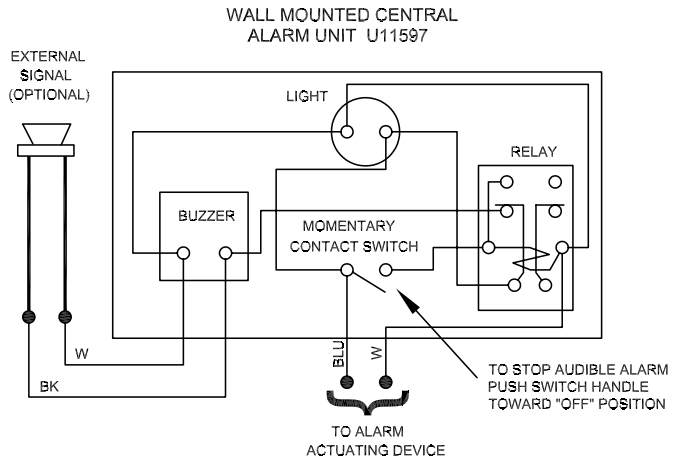

- NOTES:**
- WIRING BY EVOQUA WATER TECHNOLOGIES
 - FILED WIRING (NOT BY EVOQUA WATER TECHNOLOGIES)
 - ALL FIELD WIRING MUST CONFORM TO LOCAL ELECTRICAL CODES.
 - INSTALL APPROPRIATE OVERCURRENT PROTECTION AND DISCONNECT MEANS AS REQUIRED BY ELECTRICAL CODES.
 - WHEN ORDERING MATERIAL, ALWAYS SPECIFY MODEL AND SERIAL NUMBER OF APPARATUS.

OPTIONAL VACUUM SWITCH & ALARM SYSTEM - INSTALLATION WIRING

25.510.130.010

ISSUE 5 6-14

VACUUM REGULATOR-CHECK UNIT - 510 M/S

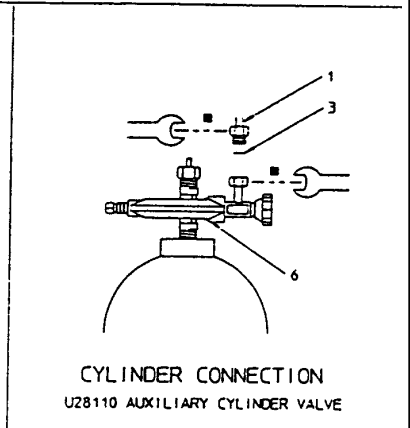
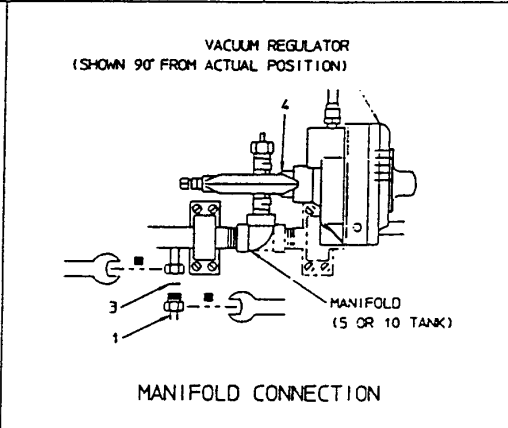
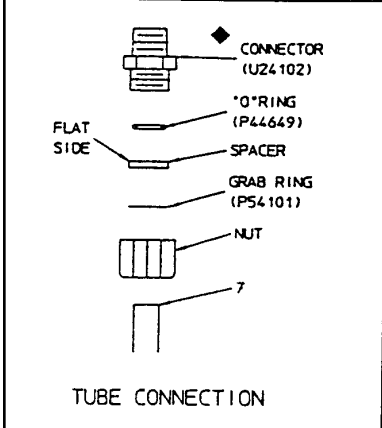
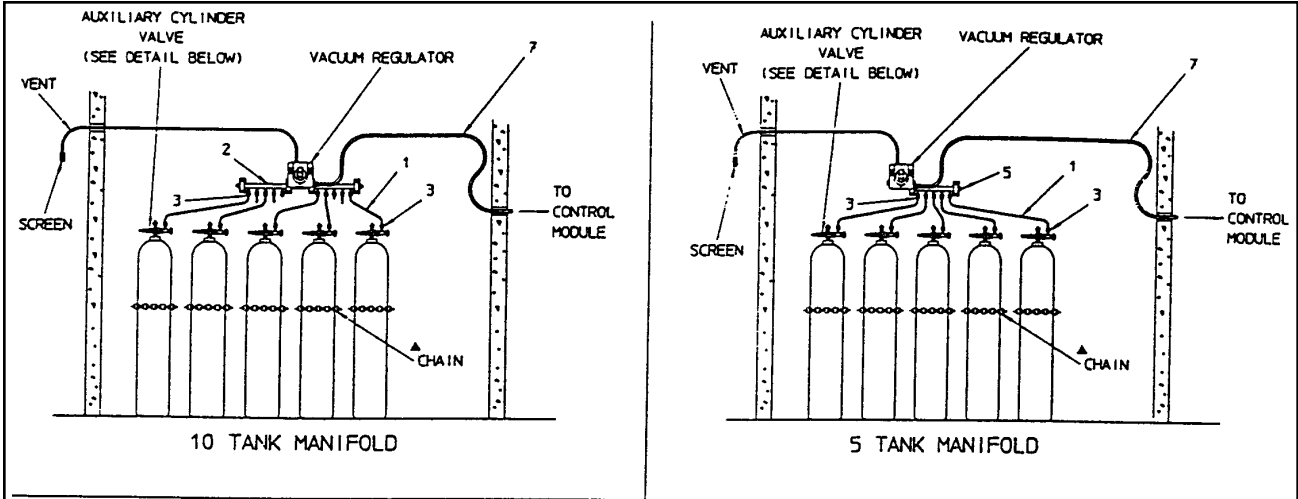

WARNING: ▲ TO AVOID POSSIBLE SEVERE PERSONAL INJURY OR EQUIPMENT DAMAGE, SUPPLY CYLINDERS MUST BE SECURED IN SUCH A MANNER (e.g., CHAIN) AS TO PREVENT THEIR BEING KNOCKED OVER.

THE STANDBY PRESSURE RELIEF VALVE MUST BE VENTED TO A TREATMENT SYSTEM OR OUTSIDE ATMOSPHERE. THE VENT LINE MUST TERMINATE IN AN AREA WHERE GAS FUMES CANNOT CAUSE DAMAGE OR INJURY TO PERSONNEL. DO NOT TERMINATE THE VENT LINE AT A LOCATION ROUTINELY USED BY PERSONNEL, SUCH AS WORK AREAS OR PATHWAYS NOR NEAR WINDOWS OR VENTILATION SYSTEM INTAKES.

CAUTION: ■ USE TWO WRENCHES ON ALL UNION CONNECTIONS. END FITTING ON TUBING MUST BE STATIONARY WHILE UNION NUT ON VALVE IS TURNED. (END FITTING IS BRAZED TO TUBING.)

NOTE: ◆ TO CONNECT FITTING TO TUBE:
 1. CUT TUBE END AT RIGHT ANGLE FOR A "SQUARE" END.
 2. LOOSEN NUT ON FITTING UNTIL ABOUT THREE THREADS ARE VISIBLE.
 3. INSERT TUBE STRAIGHT INTO FITTING UNTIL TUBE BOTTOMS ON FITTING SHOULDER. TIGHTEN NUT BY HAND.

THE CHLORINE INSTITUTE RECOMMENDS THAT FLEXIBLE CONNECTIONS BE REPLACED ANNUALLY OR SOONER IF THERE IS EVIDENCE OF DETERIORATION. SEE THE CHLORINE HANDLING MANUAL. SIMILAR RECOMMENDATIONS APPLY FOR OTHER GASES.

MANIFOLD VACUUM REGULATOR-CHECK UNIT - INSTALLATION PIPING

25.510.120.010A

ISSUE 0 12-95

VACUUM REGULATOR-CHECK UNIT - 510 M/S

REF NO.	PART NO.	DESCRIPTION
1	UXA493 OR UXB493 OR UXC493 OR UXD493 OR UXE493	FLEXIBLE CONNECTION, 3 FT. LENGTH FLEXIBLE CONNECTION, 4 FT. LENGTH FLEXIBLE CONNECTION, 6 FT. LENGTH FLEXIBLE CONNECTION, 10 FT. LENGTH FLEXIBLE CONNECTION, 15 FT. LENGTH
2	U 28837	10 TANK MANIFOLD
3	P 2519	35/64" OD LEAD GASKET (FLEX. CONNECTION TO MANIFOLD)
4	P 16191	15/16" OD LEAD GASKET (MANIFOLD TO VACUUM REGULATOR)
5	U 28834	5 TANK MANIFOLD
6	P 16191	15/16" OD LEAD GASKET (YOKE TYPE AUXILIARY CYLINDER VALVE)
7	RP68 4503	5/8" OD x 1/2" ID POLYETHYLENE TUBING (LENGTH AS REQUIRED)

WHEN ORDERING MATERIAL, ALWAYS SPECIFY MODEL AND SERIAL NUMBER OF APPARATUS.

MANIFOLD VACUUM REGULATOR-CHECK UNIT - INSTALLATION PIPING

25.510.120.010B

ISSUE 1 5-99

VACUUM REGULATOR-CHECK UNIT - 510 M/S

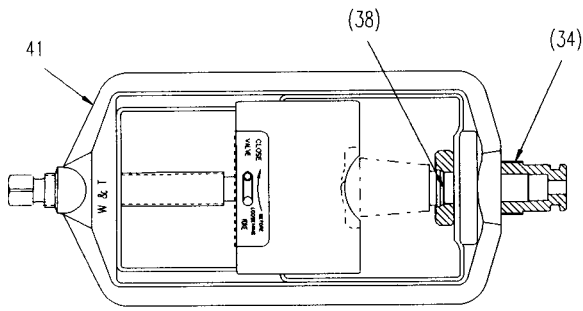

UNIVERSAL YOKE

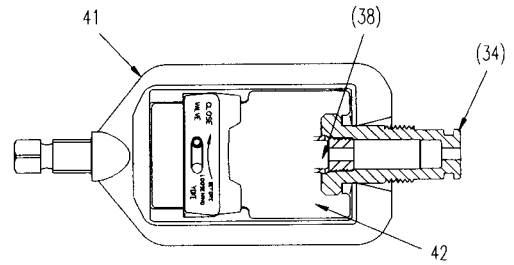

CHLORINE INSTITUTE YOKE

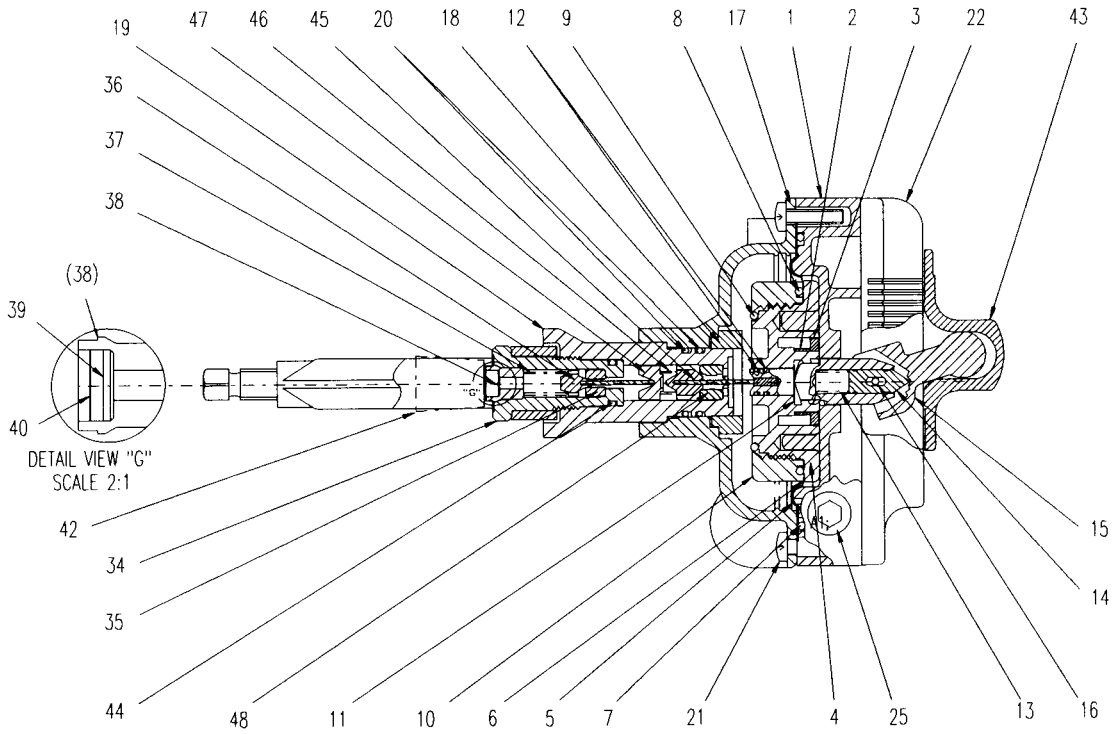

DETAIL VIEW "G"
SCALE 2:1

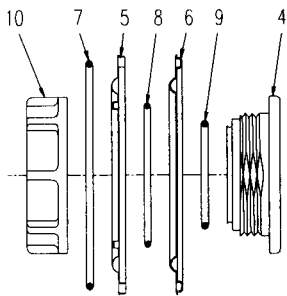

DIAPHRAGM & O-RING DETAIL

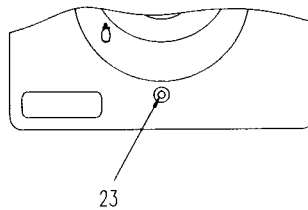

FRONT COVER DETAIL

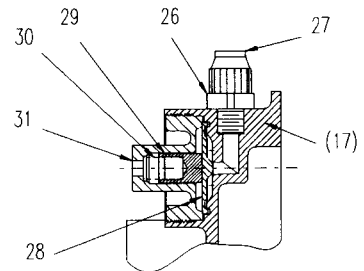

PRESSURE RELIEF

VACUUM REGULATOR-CHECK UNIT (STANDARD) - PARTS

AAB3647 - CHLORINE INSTITUTE YOKE, AAB3656 - UNIVERSAL YOKE

25.510.000.010A

ISSUE 2 5-99

VACUUM REGULATOR-CHECK UNIT - 510 M/S

KEY NO.	PART NO.	QTY.	DESCRIPTION
1	AOK4480	1	FRONT HOUSING
2	AOO5571	1	SPRING, CIRCULAR
3	APQ4366	1	RETAINER
4	AAA4487	1	DIAPHRAGM BACKING PLATE
5	APQ5464	1	OPERATING DIAPHRAGM
6	AAA1616	1	BACKING, DIAPHRAGM
7	AMK5553	1	O-RING (246)
8	P 51401	1	O-RING (232)
9	ALI5542	1	O-RING (226)
10	ASS4538	1	BACKING PLATE NUT
11	AAB3089	1	OPERATING SHAFT
12	APQ5558	2	O-RING (011)
13	P 41078	1	SPRING PAWL
14	AAB2699	1	OPERATING LEVER PAWL
15	AMK5341	1	OPERATING LEVER
16	AAB1251	1	PIVOT PIN
17	AAB2693	1	BACK HOUSING
18	AAB2690	1	NUT HOUSING RETAINER
19	AAB3092	1	HOUSING STEM, SECONDARY CHECK
20	P 47152	2	O-RING (119)
21	AAA9027	6	FRONT/BACK HOUSING ASSEMBLY SCREW
22	AKG5438	1	COVER, FRONT
23	AAA9030	1	COVER/FRONT HOUSING ASSEMBLY SCREW
24	P 34374	1	CAP PLUG
25	P 52090	1	PLUG BLACK, 1/2 NPT PIPE
26	P 39233	1	UNION, CONNECTOR
27	PXB39234	1	NUT
28	AAB3143	1	SAFETY VALVE DIAPHRAGM
29	P 41079	1	SAFETY VALVE PLUNGER
30	AIA4045	1	SAFETY VALVE PLUNGER SPRING
31	APM4519	1	SAFETY VALVE PLUG
32	AHS4646	1	WARNING LABEL
33	ADH4733	1	CAUTION LABEL
34	AKG5346	1	REGULATOR NIPPLE (CHLORINE INSTITUTE)
	OR		
	AAB2291	1	REGULATOR NIPPLE (UNIVERSAL)
35	AAB1736	1	REGULATOR SEAT
36	ANM5366	1	STEM, REGULATOR UNIT
37	APQ4110	1	SPRING REGULATOR
38	AIC5355	1	RETAINER (CHLORINE INSTITUTE)
	OR		
	AAB2294	1	RETAINER (UNIVERSAL)
39	AAA7106	1	SCREEN
40	AAA7109	1	FILTER
41	U23016	1	YOKE (CHLORINE INSTITUTE)
	OR		
	AAB3731	1	YOKE (UNIVERSAL)
42	P 44884	1	CORK
43	ARQ4529	1	KNOB OPERATING LEVER
44	AKG5549	1	O-RING (113)
45	AIC5321	1	STEM, SECONDARY VALVE UNIT
46	AKG4105	1	SPRING SECONDARY VALVE
47	AAA7094	1	GUIDE SPRING SECONDARY VALVE
48	AAB1733	1	SECONDARY CHECK SEAT

WHEN ORDERING MATERIAL, ALWAYS SPECIFY MODEL AND SERIAL NUMBER OF APPARATUS.

VACUUM REGULATOR-CHECK UNIT (STANDARD) - PARTS LIST

AAB3647 - CHLORINE INSTITUTE YOKE, AAB3656 - UNIVERSAL YOKE

25.510.000.010B

ISSUE 2 5-99

VACUUM REGULATOR-CHECK UNIT - 510 M/S

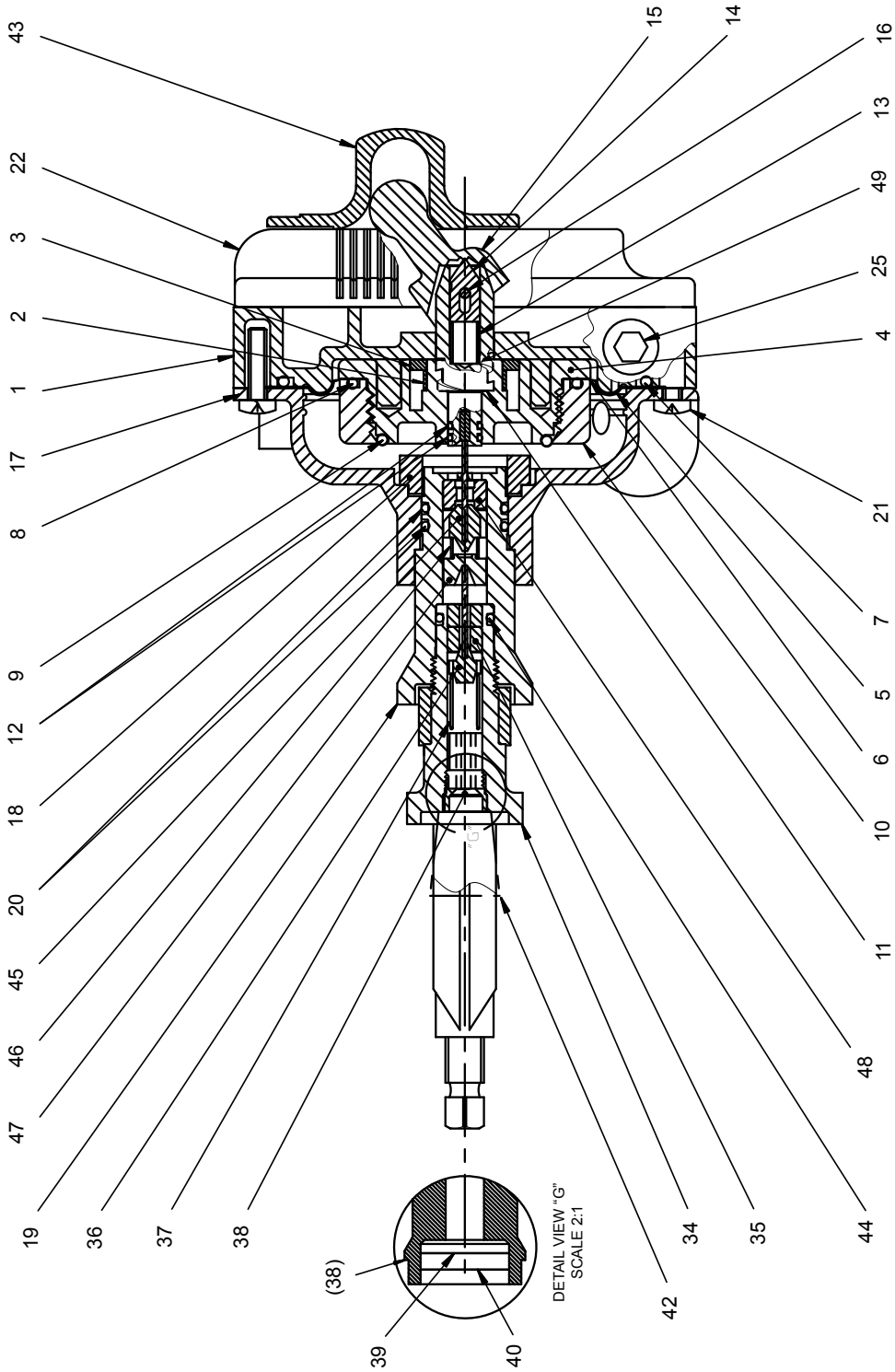

VACUUM REGULATOR-CHECK UNIT (AUTOMATIC SWITCHOVER) - PARTS

AAB3671 - CHLORINE INSTITUTE YOKE, AAB3653 - UNIVERSAL YOKE

25.510.000.020A

ISSUE 3 12-07

VACUUM REGULATOR-CHECK UNIT - 510 M/S

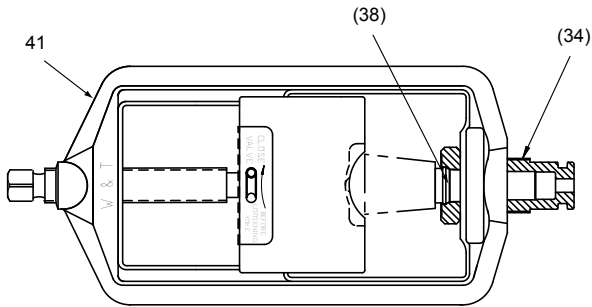

UNIVERSAL YOKE

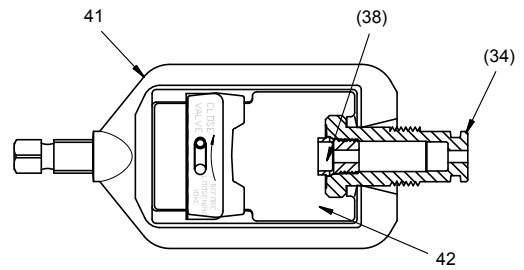

CHLORINE INSTITUTE YOKE

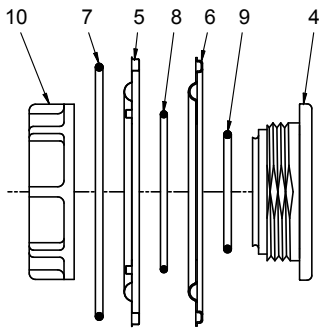

DIAPHRAGM & O-RING DETAIL

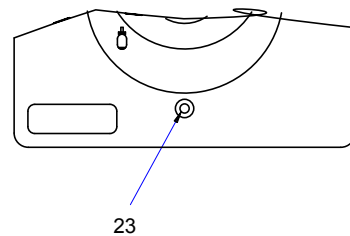

FRONT COVER DETAIL

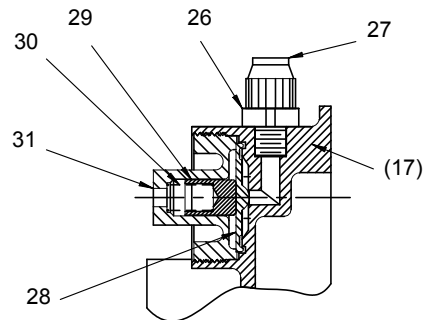
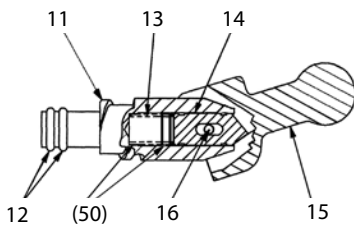

PRESSURE RELIEF

VACUUM REGULATOR-CHECK UNIT (AUTOMATIC SWITCHOVER) - PARTS

AAB3671 - CHLORINE INSTITUTE YOKE, AAB3653 - UNIVERSAL YOKE

25.510.000.020B

ISSUE 3 12-07

VACUUM REGULATOR-CHECK UNIT - 510 M/S

KEY NO.	PART NO.	QTY	DESCRIPTION
1	AOK4480	1	Front Housing
2	AOO5571	1	Spring, Circular
3	APQ4366	1	Retainer
4	AAA4487	1	Diaphragm Backing Plate
5	APQ5464	1	Operating Diaphragm
6	AAA1616	1	Backing, Diaphragm
7	AMK5553	1	O-Ring (246)
8	P51401	1	O-Ring (232)
9	ALI5542	1	O-Ring (226)
10	ASS4538	1	Backing Plate Nut
11	AAB3089	1	Operating Shaft
12	APQ5558	2	O-Ring (011)
13	P41078	1	Spring Pawl
14	AAB2699	1	Operating Lever Pawl
15	ALE4534	1	Operating Lever
16	AAB1251	1	Pivot Pin
17	AAB2693	1	Back Housing
18	AAB2690	1	Nut Housing Retainer
19	AAB3092	1	Housing Stem, Secondary Check
20	P47152	2	O-Ring (119)
21	AAA9027	6	Front/Back Housing Assembly Screw
22	AMG4473	1	Cover, Front
23	AAA9030	1	Cover/Front Housing Assembly Screw
24	P34374	1	Cap Plug
25	P52090	1	Plug Black, 1/2 NPT Pipe
26	P39233	1	Union, Connector
27	PXB39234	1	Nut
28	AAB3143	1	Safety Valve Diaphragm
29	P41079	1	Safety Valve Plunger
30	AIA4045	1	Safety Valve Spring
31	APM4519	1	Safety Valve Plug
32	AHS4646	1	Warning Label
33	ADH4733	1	Caution Label

WHEN ORDERING MATERIAL, ALWAYS SPECIFY MODEL AND SERIAL NUMBER OF APPARATUS.

VACUUM REGULATOR-CHECK UNIT (AUTOMATIC SWITCHOVER) - PARTS

AAB3671 - CHLORINE INSTITUTE YOKE, AAB3653 - UNIVERSAL YOKE

25.510.000.020C

ISSUE 0 12-07

VACUUM REGULATOR-CHECK UNIT - 510 M/S

KEY NO.	PART NO.	QTY	DESCRIPTION
34	AKG5346 OR AAB2291	1	Regulator Nipple (Chlorine Institute)
35	AAB1736	1	Regulator Nipple (Universal)
36	ANM5366	1	Regulator Seat
37	APQ4110	1	Stem, Regulator Unit
38	AIC5355 OR AAB2294	1	Spring Regulator
39	AAA7106	1	Retainer (Chlorine Institute)
40	AAA7109	1	Retainer (Universal)
41	U23016 OR AAB3731	1	Screen
42	P44884	1	Filter
43	ARQ4529	1	Yoke (Chlorine Insititute)
44	AKG5549	1	Yoke (Universal)
45	AIC5321	1	Cork
46	AKG4105	1	Knob Operating Lever
47	AAA7094	1	O-Ring (113)
48	AAB1733	1	Stem, Secondary Valve Unit
49	P19685	2	Spring, Secondary Valve
			Guide Spring, Secondary Valve
			Secondary Check Seat
			Washer, #6

WHEN ORDERING MATERIAL, ALWAYS SPECIFY MODEL AND SERIAL NUMBER OF APPARATUS.

VACUUM REGULATOR-CHECK UNIT (AUTOMATIC SWITCHOVER) - PARTS

AAB3671 - CHLORINE INSTITUTE YOKE, AAB3653 - UNIVERSAL YOKE

25.510.000.020D

ISSUE 0 12-07

VACUUM REGULATOR-CHECK UNIT - 510 M/S

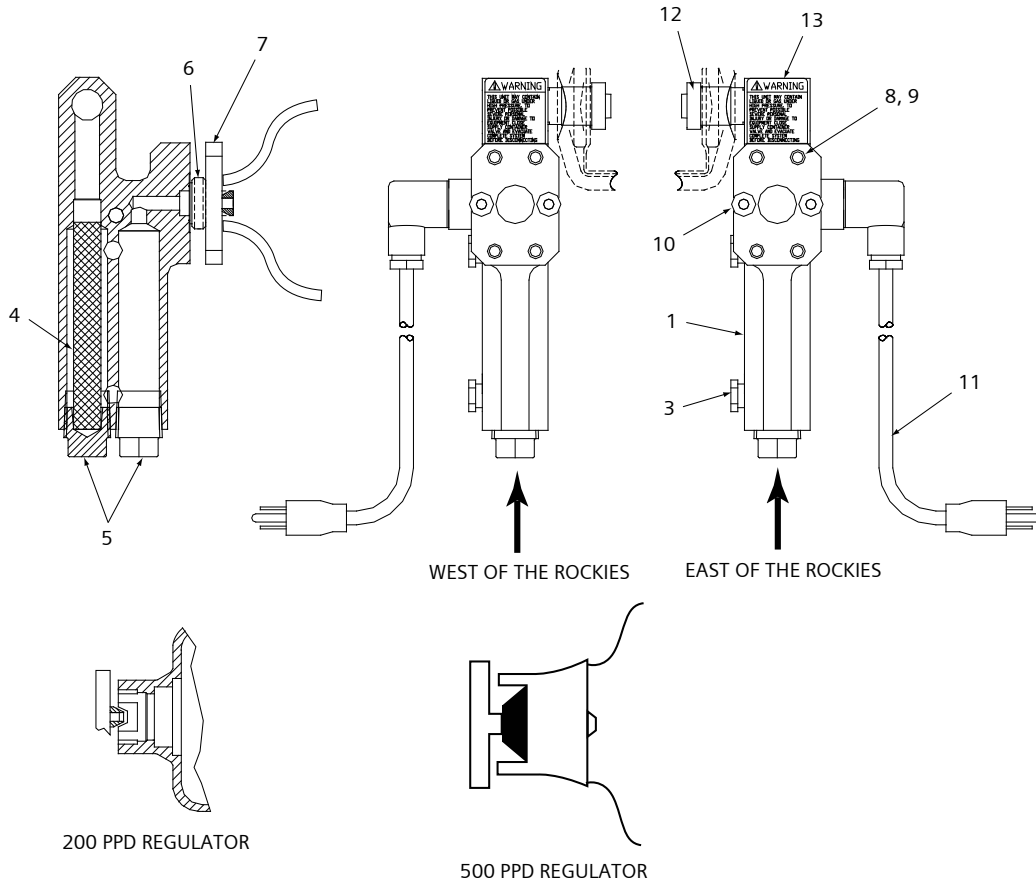

KEY NO.	PART NO.	QTY.	DESCRIPTION
1	AAB2270 OR AAB2267	1	BODY (EAST) BODY (WEST)
2	AAB2513	1	HEATER
3	AAA2562	2	1/4" NPT PLUG
4	ALJ3768	1	FILTER
5	ANM3773	2	3/4" NPT PLUG
6	P 16191	1	LEAD GASKET
7	AAB2696	1	COLLAR
8	AAA9879	4	SCREWS
9	AAA9996	4	WASHER
10	AAA1211	2	SPACER
11	AAA4502	1	ELECR. CORD, ASSEMBLY
12	P 50548	1	INLET NIPPLE
13	AAA2496	1	WARNING LABEL
14	AAA2559	1	LOGO
15	PXD4027	1	PADDED BAG

WHEN ORDERING MATERIAL, ALWAYS SPECIFY MODEL AND SERIAL NUMBER OF APPARATUS.

TON CONTAINER KIT - PARTS

AAB2507 (XAA1022) - EAST OF ROCKY MTS., AAB2510 (XAA1023) - WEST OF ROCKY MTS.

25.510.001.010

ISSUE 3 9-07

VACUUM REGULATOR-CHECK UNIT - 510 M/S

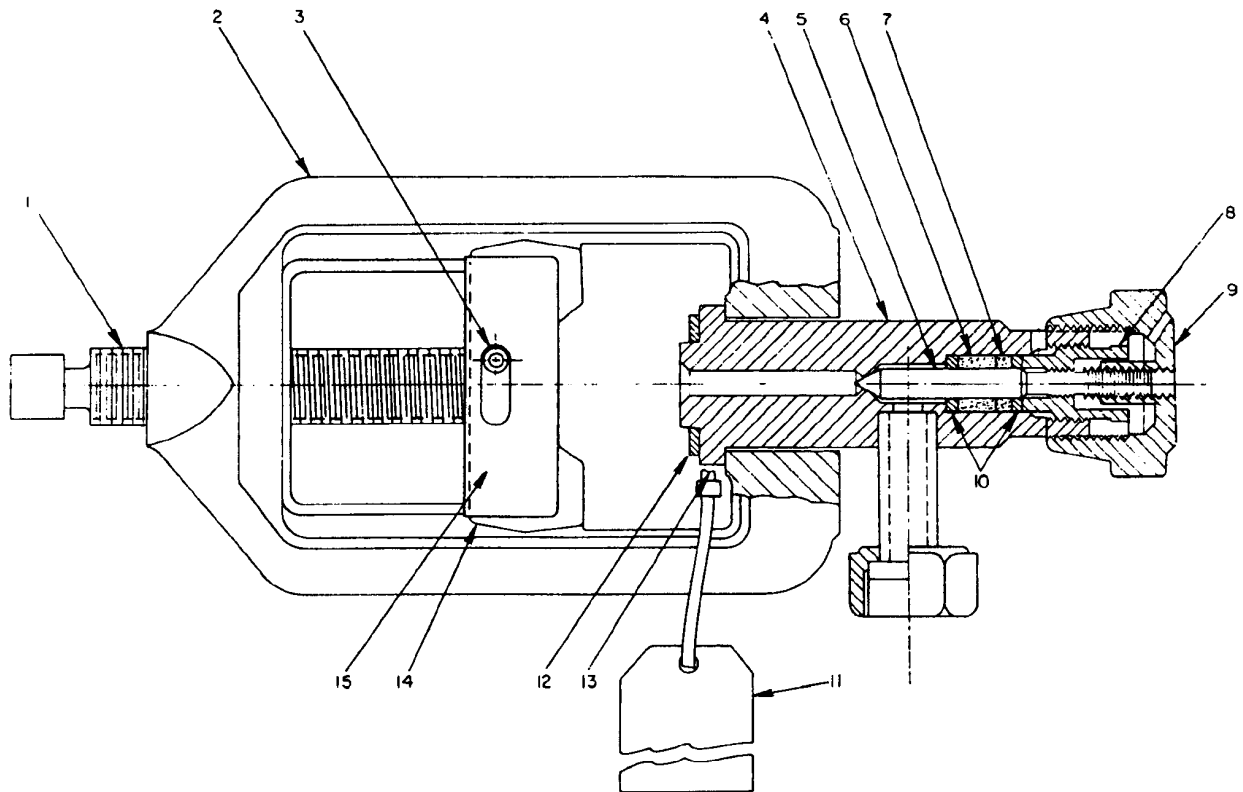

KEY NO.	PART NO.	QTY.	DESCRIPTION
1	P19386	1	YOKE SCREW
2	P58460	1	YOKE
3	P39774	1	GROOVE-PIN (STL.) 1/8" DIA. X 7/8" LG.
4	U28109	1	VALVE BODY
5	P2949	1	STEM
6	P45544	1	PACKING
7	P45547	1	PLASTIC WASHER
8	P58540	1	PACKING NUT
9	P2947	1	HANDLE
10	P45546	2	COLLAR
11	L3076	1	INSTRUCTION CARD
12	P16191	1	LEAD GASKET
13	P41796	1	CABLE STRAP
14	P25121	1	YOKE CLAMP
15	P59369	1	TAG

WHEN ORDERING MATERIAL, ALWAYS SPECIFY MODEL AND SERIAL NUMBER OF APPARATUS.

U28110 AUXILIARY CYLINDER VALVES - PARTS

50.150.001.012

ISSUE 3 9-07

VACUUM REGULATOR-CHECK UNIT - 510 M/S

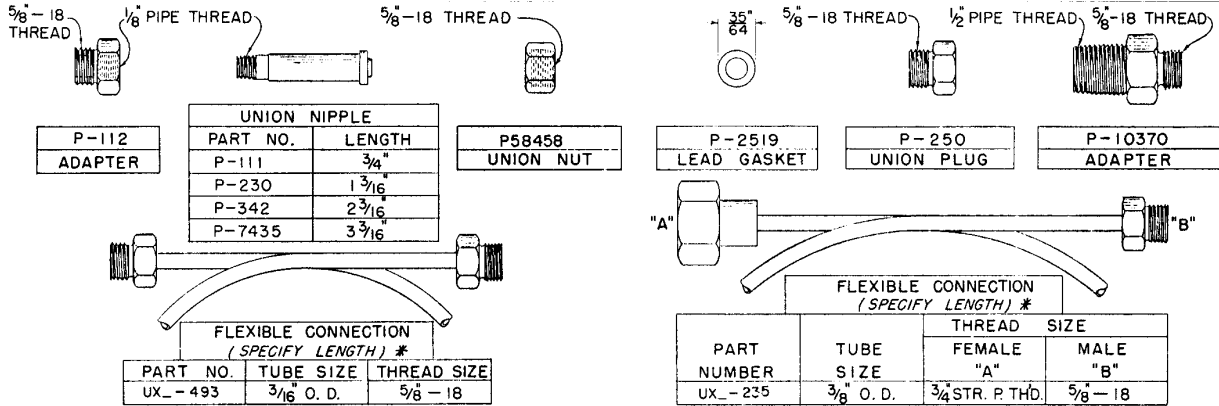

MEDIUM FLEXIBLE CONNECTIONS & ACCESSORIES

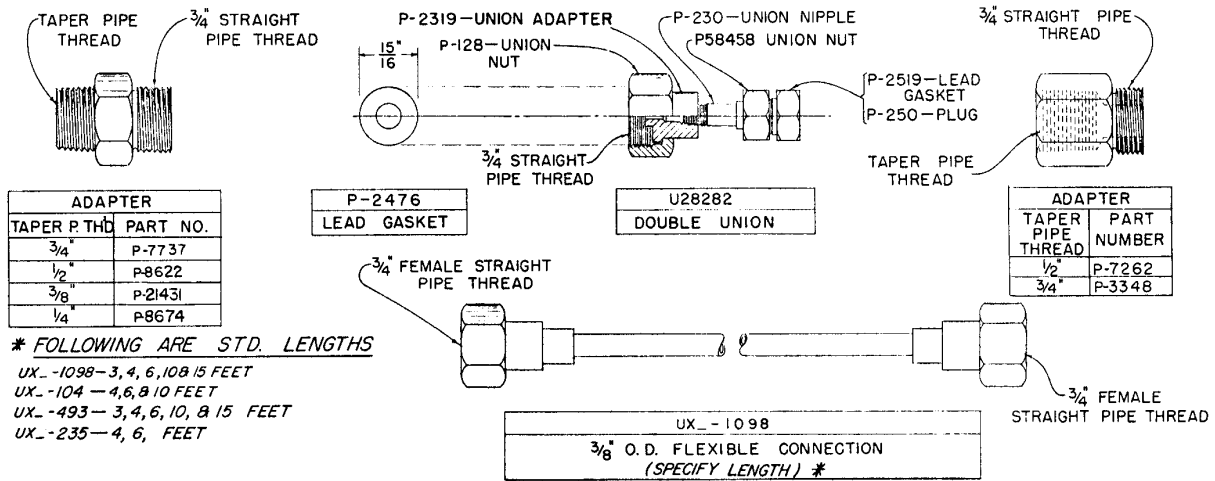

LARGE FLEXIBLE CONNECTIONS & ACCESSORIES

NOTE: THE CHLORINE INSTITUTE RECOMMENDS THAT FLEXIBLE CONNECTIONS BE REPLACED ANNUALLY OR SOONER IF THERE IS EVIDENCE OF DETERIORATION. SEE CHLORINE HANDLING MANUAL. SIMILAR RECOMMENDATIONS APPLY FOR SULFUR DIOXIDE AND CARBON DIOXIDE.

WHEN ORDERING MATERIAL, ALWAYS SPECIFY MODEL AND SERIAL NUMBER OF APPARATUS.

FLEXIBLE CONNECTIONS & ACCESSORIES - PARTS

50.150.007.021

ISSUE 15 5-07

6 PREVENTIVE MAINTENANCE KIT AND SPARE PARTS LIST

500 LB/24 HR VACUUM REGULATOR-CHECK UNIT

DESCRIPTION	PART NO.
Preventive Maintenance Kit	AAA1160

ADDITIONAL SPARE PARTS LIST

QTY.	DESCRIPTION	PART NO.
25	Lead Gasket (for Chlorine Institute yoke design)	P16191
	-OR-	
25	Lead Gasket for Vacuum Regulator (for universal yoke design)	P60134
1	Hanger (Chlorine Institute yoke)	AAB2369
	-OR-	
1	Hanger (universal yoke)	AAB2372
2	Filter Disc	AAA7109
1	Halocarbon Grease	U27546
1	White Lead	U27104
1	Screen for Vent Line	U29305

VACUUM REGULATOR-CHECK UNIT - 510 M/S**TOOLS**

QTY.	DESCRIPTION	PART NO.
1	Secondary check seat removal tool	AAB2378
1	Secondary check seat insertion tool	AAB2402
1	Nipple seat insertion/removal tool	AAB2375
1	Wrench - multi-purpose	AAB1952
1	Hanger for Standard Yoke	AAB2369
1	Hanger for Universal Yoke	AAB2372
1	Seat Installation/Removal Tool	AAB2375
1	Remove Seat Housing Tool, 500 PPD	AAB2378
1	Installation Seat Housing Tool, 500 PPD	AAB2402
1	Installation/Removal Nipple Seat Tool	AAB2375
1	Nipple Assembly, 200 PPD	AAC5369
1	Nipple Assembly, 500 PPD	AAC5366
1	Extended Nipple (for use with automatic shutoff valves)	AAC2804

**CHLORINE HANDLING
MANUAL**
(Cl₂)

BOOK NO. WT.025.000.001.UA.IM.0614

CHLORINE HANDLING MANUAL

REGIONAL OFFICES

INSTALLATION, OPERATION, MAINTENANCE, AND SERVICE INFORMATION

Direct any questions concerning this equipment that are not answered in the instruction book to the Reseller from whom the equipment was purchased. If the equipment was purchased directly from Evoqua Water Technologies, Colorado Springs, CO contact the office indicated below.

UNITED STATES

725 Wooten Road
Colorado Springs, CO 80915
TEL: (800) 524-6324

CANADA

If the equipment was purchased directly from Evoqua Water Technologies, Canada, contact the nearest office indicated below.

ONTARIO

Evoqua Water Technologies Ltd.
2045 Drew Road
Mississauga, Ontario
L5S 1S4
(905) 944-2800

QUEBEC

Evoqua Technologies des Eaux Itee
505 Levy Street
St. Laurent, Quebec
H4R 2N9
(450) 582-4266

CHLORINE HANDLING MANUAL

CHLORINE HANDLING MANUAL

WARNING:

CHLORINE IS A HAZARDOUS CHEMICAL THAT CAN CAUSE INJURY AND DEATH IF NOT HANDLED PROPERLY. THIS MANUAL CONTAINS ONLY GENERAL INFORMATION ON THE PHYSICAL PROPERTIES, STORAGE, AND HANDLING OF CHLORINE. IT IS NOT INTENDED TO REPLACE OR LIMIT SAFETY PROCEDURES IN YOUR FACILITY.

SAFETY PROCEDURES IN AN INDUSTRIAL SETTING MUST BE DESIGNED IN ACCORDANCE WITH ALL GOVERNMENTAL REGULATIONS AND NATIONAL SAFETY CODES, AFTER GIVING FULL CONSIDERATION TO THE SPECIFIC NEEDS OF THE INDUSTRIAL FACILITY INVOLVED.

EVOQUA WATER TECHNOLOGIES CANNOT ANTICIPATE THE SPECIFIC SAFETY PROCEDURES REQUIRED AT EVERY INDUSTRIAL FACILITY. ACCORDINGLY, EVOQUA WATER TECHNOLOGIES DOES NOT GUARANTEE THAT SAFETY PROCEDURES DESIGNED IN ACCORDANCE WITH THIS MANUAL WILL COMPLETELY ELIMINATE HAZARDS AND THUS ASSUMES NO LIABILITY FOR ACCIDENTS THAT MAY OCCUR IN YOUR FACILITY.

READ THIS ENTIRE MANUAL AND BE FULLY FAMILIAR WITH YOUR EQUIPMENT AND YOUR ENTIRE INDUSTRIAL SYSTEM SO THAT THE SAFETY PROCEDURES YOU ESTABLISH WILL MEET THE NEEDS OF THE EMPLOYEES IN YOUR FACILITY. READING ONLY PART OF THE MANUAL WILL NOT HELP YOU ANALYZE THE NEEDS OF YOUR FACILITY. CONTACT YOUR CHLORINE SUPPLIER, THE CHLORINE INSTITUTE, INC., OR SIMILAR ORGANIZATION TO OBTAIN A MATERIAL SAFETY DATA SHEET (MSDS) AND MORE DETAILED INFORMATION ON CHLORINE. INFORMATION IS AVAILABLE FROM: THE CHLORINE INSTITUTE, INC., 1300 WILSON BOULEVARD, ARLINGTON, VA 22209.

PLEASE NOTE THE PUBLICATION DATE AND POSSIBLE OBSOLESCENCE OF THIS MATERIAL AS A RESULT OF SCIENTIFIC AND MEDICAL DEVELOPMENTS AFTER THE DATE OF PUBLICATION. THIS APPLIES TO ALL MATERIALS YOU REVIEW IN THE COURSE OF DEVELOPING SAFETY PROCEDURES FOR USE AT YOUR FACILITY.

Table Of Contents

	PARA. NO.
Introduction.....	1
Technical Data and Characteristics of Chlorine	2
Supply Containers.....	3
Maximum Gas Withdrawal Rates	3.1
Manifolding for Gas Withdrawal.....	3.1.1
Maximum Liquid Withdrawal Rate	3.2
Manifolding for Liquid Withdrawal.....	3.2.1
Container Valves.....	3.3
Pressure Relief Devices.....	3.4
Storage of Containers	3.5

Table Of Contents (Cont'd)

Handling Containers	3.6
Using Containers.....	3.7
Piping.....	4
Piping Materials and Joints.....	4.1
Gas Piping Installation Requirements	4.2
Liquid Piping Installation Requirements	4.3
Pressure Relief and Vent Piping Requirements.....	4.4
Valves.....	4.5
Pressure Gauges and Switches	4.6
Pressure Relief Devices.....	4.7
Preparation for Use	4.8
Personnel Safety.....	5
General.....	5.1
Health Hazards	5.2
Safety Precautions	5.3
Emergency Action Plans	5.4
Chemical Disposal Facilities	5.5

1 INTRODUCTION

This manual discusses the characteristics, storage and handling of chlorine used with Evoqua Water Technologies equipment. Chlorine is used with Evoqua Water Technologies equipment primarily as a disinfectant in water or wastewater treatment.

WARNING:

CHLORINE IS HAZARDOUS. TO AVOID SEVERE PERSONAL INJURY OR DEATH BY SUFFOCATION, READ THIS MANUAL AND THE CHLORINE SUPPLIER'S PRECAUTIONS BEFORE HANDLING OR CONNECTING CHLORINE TO EVOQUA WATER TECHNOLOGIES EQUIPMENT.

WHEN WORKING WITH CHLORINE:

ENSURE THAT APPROVED, SELF-CONTAINED BREATHING APPARATUS IS ALWAYS AVAILABLE AND PERSONNEL ARE PROPERLY TRAINED IN ITS USE.

ENSURE THAT SAFETY EQUIPMENT, SUCH AS VENTILATION FANS AND BREATHING APPARATUS, IS INSPECTED AND MAINTAINED IN ACCORDANCE WITH THE MANUFACTURER'S INSTRUCTIONS.

ENSURE THAT APPROPRIATE PLACARDS AND WARNING SIGNS ARE IN PLACE AND PROMINENTLY DISPLAYED IN THE AREAS WHERE THE GAS IS STORED.

IN CASES OF ACCIDENT:

USE SAFETY EQUIPMENT TO PROTECT THE RESCUER AND MOVE VICTIM TO FRESH AIR. IF BREATHING HAS STOPPED, START ARTIFICIAL RESPIRATION IMMEDIATELY.

IF HEART HAS STOPPED, START CPR (CARDIOPULMONARY RESUSCITATION) IMMEDIATELY. IN ALL CASES, OBTAIN MEDICAL ATTENTION AS SOON AS POSSIBLE.

TO AVOID ACCIDENTAL GAS RELEASE:

KNOWLEDGEABLE DESIGN PERSONNEL SHOULD OVERSEE AND APPROVE EQUIPMENT INSTALLATION AND SUITABILITY OF THE SYSTEM FOR WHICH IT IS INTENDED. QUALIFIED PERSONNEL SHOULD PERFORM PERIODIC INSPECTION TO ENSURE PROPER MAINTENANCE OF THE EQUIPMENT.

MONITOR SAFETY PROGRAMS AND CONDUCT PERIODIC TRAINING PROGRAMS, ESPECIALLY ON EMERGENCY SITUATIONS. SAFETY PROGRAMS ARE AVAILABLE FROM YOUR GAS SUPPLIER.

LOCAL LAWS:

UNDER NO CIRCUMSTANCES SHOULD THE INFORMATION IN THIS BOOK BE CONSTRUED AS SUBSTITUTING FOR OR SUPERSEDING ANY LOCAL, STATE, OR FEDERAL LAWS AND REGULATIONS CONCERNING THE STORAGE, HANDLING, OR USE OF CHLORINE.

CHLORINE HANDLING MANUAL

2 TECHNICAL DATA AND CHARACTERISTICS OF CHLORINE

The following general information on chlorine may be useful in planning a chlorinator installation; however, a specific application may require more information than that included here. For further information, consult your chlorine supplier, the Chlorine Institute, Inc., or similar organization.

Chlorine in commerce is a liquefied gas under pressure. It is a clear, amber-colored liquid. The gas has a greenish-yellow color and a strong, pungent odor. It is an irritant to the skin and respiratory system. In the moisture-free state at ordinary temperatures, it is relatively non-corrosive. In the presence of moisture, however, it is highly corrosive. Accordingly, every precaution should be taken to avoid leaks, to stop them promptly if they occur, and to keep moisture out of valves, tubing, etc., not specifically designed to handle moist chlorine. Among the important physical properties of chlorine are:

Specific Gravity, Dry Gas
2.48 at 32° F and 1 atm referred to air.

Specific Gravity, Liquid
1.47 at 32° F and 53 . 5 psia.

Liquid to Gas volume Ratio
1:456.5 at 32° F and 1 atm.

Latent heat of Vaporization
123.9 Btu per lb at boiling point, -29.2° F.

Specific Volume, Dry Gas
1 lb = 4.99 of at 32° F and 1 atm.

Specific Volume, Liquid
1 lb = 0.0109 cf at 32° F and 53.5 psia.

Weight, Dry Gas
1 cf = 0.2006 lb at 32° F and 1 atm.

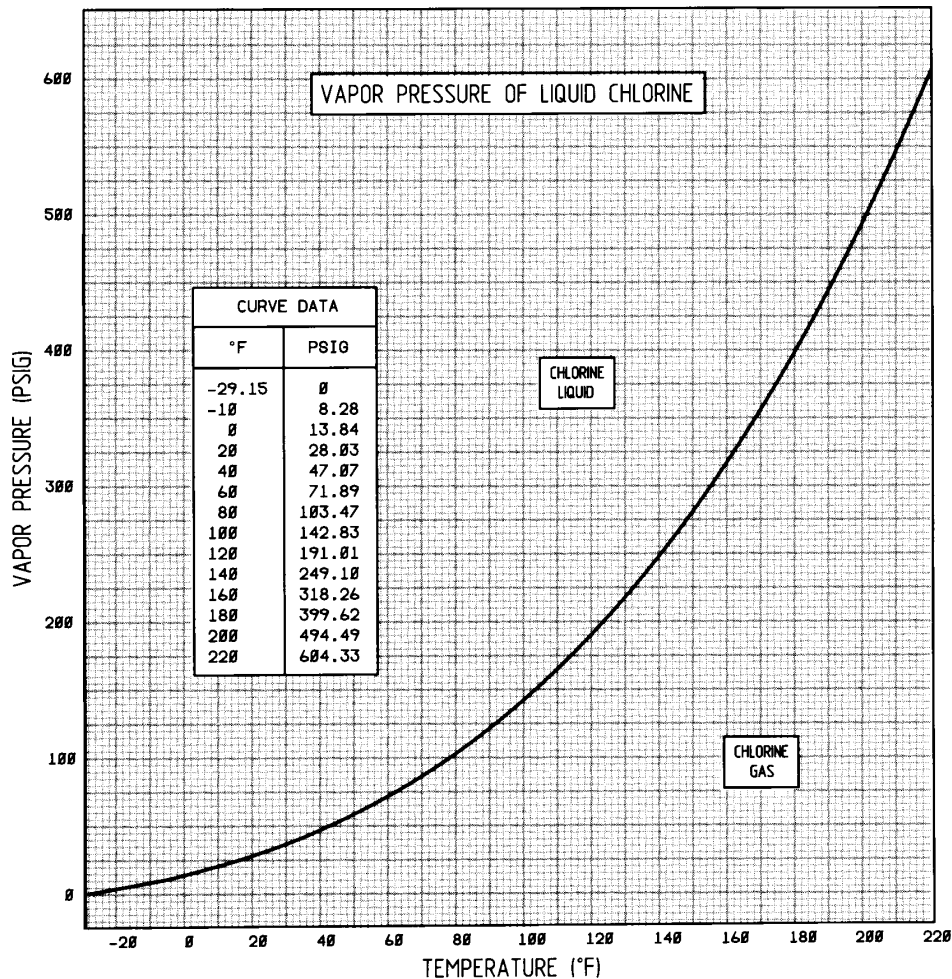

Figure 1 – Chlorine Pressure vs Temperature

SOURCE: THE CHLORINE MANUAL, FIFTH EDITION, PUBLISHED BY THE CHLORINE INSTITUTE, INC.

CHLORINE HANDLING MANUAL

Weight, Liquid

1 cf = 91.56 lb at 32° F.

Solubility in Water*

6.93 lbs./100 gals at 60° F and 1 atm.

Pressure vs Temperature

See Figure 1

***NOTE: Theoretical values shown. Actual solubility in water based on chlorinator performance has proven to be 3500 ppm or 2.92 lbs/100 gals maximum.**

Chlorine is an oxidizing agent and will support combustion but is not explosive or flammable. Many organic chemicals will react with chlorine, some violently. Steel will ignite spontaneously in the presence of chlorine at 483° F.

3 SUPPLY CONTAINERS

Table 1 gives details on the supply containers most commonly used with Evoqua Water Technologies equipment.

Some large installations that would normally use single unit tank cars but are not serviced by railroad facilities use tank motor vehicles (tank trailers) which usually range in capacity from 15 to 22 tons.

All supply containers must conform to appropriate Department of Transportation (DOT) and Canadian Transport Commission (CTC) regulations. It is the responsibility of the supply container manufacturer and the chlorine supplier to meet these requirements.

3.1 RATES

In general, using a remote vacuum type chlorinator, the maximum sustained gas withdrawal rate at which chlorine may be taken from a 100 or 150 pound cylinder is one pound per day per degree Fahrenheit (1.0 lb/24 hrs/°F). The corresponding rate for ton containers is about 8.0 lbs/24 hrs/°F. At an assumed liquid temperature of 70° F (and using a remote vacuum type chlorinator) the above figures translate into 70 lbs/24 hrs for cylinders and 560 lbs/24 hrs for ton containers. For a direct feed cylinder pressure operated chlorinator these rates become 42 and 336 lbs/24 hrs respectively. These rates can be increased substantially for brief periods. Do not place containers in a water bath or apply direct heat in order to permit higher withdrawal rates.

It is not practical to withdraw chlorine as a gas from tank cars (or tank trailers).

3.1.1 MANIFOLDING FOR GAS WITHDRAWAL

When higher gas withdrawal rates are required, cylinders or the gas valves (upper) of ton containers may be manifolded. A typical arrangement for manifolding cylinders is shown in Figure 2.

If cylinders or ton containers are manifolded, it is essential that all supply containers be at the same temperature to prevent the transfer of liquid chlorine from a warmer container to a cooler container, possibly resulting in a container becoming overfilled through reliquefaction of chlorine in the cooler container.

TABLE 1 - CHLORINE CONTAINER INFORMATION

TYPE OF CONTAINER	NET WEIGHT	TARE WEIGHT	GROSS WEIGHT	OUTSIDE DIAMETER	LENGTH
CYLINDERS	100 lb	63 - 115 lb	163 - 215 lb	8-1/4" - 10-3/4"	3'3-1/2" - 4'11"
	150 lb	85 - 140 lb	235 - 290 lb	10-1/4" - 10-3/4"	4'5" - 4'8"
TON CONTAINER	2000 lb	1300 - 1650 lb	330 - 3650 lb	2'6"	6'7-3/4" - 6'10-1/2"
SINGLE UNIT TANK CARS	16 tons	-	-	10'5" - 12'0"	32'2" - 33'3"
	30 tons	-	-	12'4-1/2" - 13'7"	33'10" - 35'11-1/2"
	55 tons	-	-	14'3" - 15'1"	29'9" - 43'0"
	85 tons	-	-	14'11" - 15'1"	43'7" - 50'0"
	90 tons	-	-	14'11" - 15'1"	45'8" - 47'2"

Dimensional data from Chlorine Manual, Fifth Edition, published by the Chlorine Institute, Inc.

(1) The 150 lb cylinder is generally most readily available. Either the 100 lb or 150 lb size may be shipped full or empty via truck or rail in small lots or in full truck or carloads.

(2) Chlorine from Single Unit Tank Cars is generally unloaded directly from the car as needed in order to eliminate the necessity of storage tanks. Cars are leased to the consumer during this period and are consigned to private sidings only. Two parallel tracks are recommended to facilitate the handling of cars and to permit continuous operation without shut-down periods while cars are being switched.

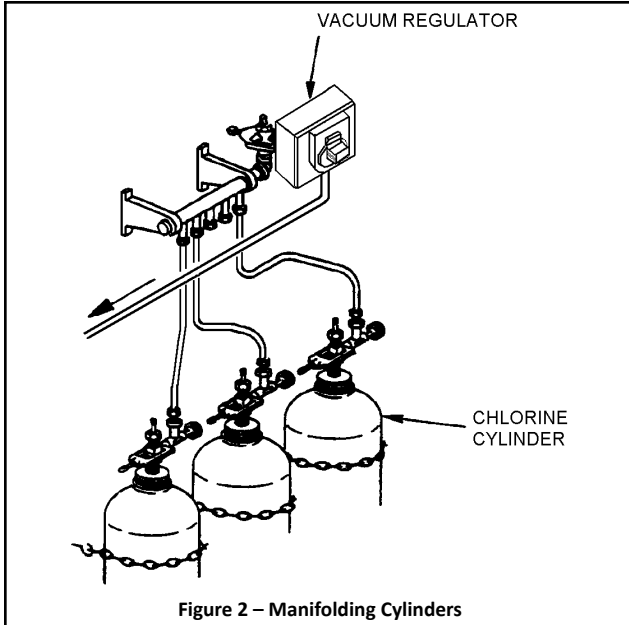

Figure 2 – Manifolding Cylinders

3.2 MAXIMUM LIQUID WITHDRAWAL RATE

The generally accepted alternate to manifolding ton containers is to withdraw liquid chlorine from the lower valve and use an evaporator. By this means, a ton container can be emptied in approximately five hours, which is equivalent to 9600 lbs/24 hrs.

Liquid can be withdrawn from tank cars at up to nearly 8,000 pounds per hour, or 192,000 pounds per 24 hours.

3.2.1 MANIFOLDING FOR LIQUID WITHDRAWAL

WARNING: IN ACCORDANCE WITH CHLORINE INSTITUTE RECOMMENDATIONS, DO NOT MANIFOLD TON CONTAINERS FOR SIMULTANEOUS LIQUID CHLORINE WITHDRAWAL. THIS MANIFOLDING CAN CAUSE OVER-PRESSURIZATION AND RUPTURE.

3.3 CONTAINER VALVES

Standard cylinder and ton container valves are identical in design, except that the cylinder valve includes a pressure relief device. Cylinder valves are shown in Figure 3 and ton container valves in Figure 4.

See Figure 5 for captive yoke type auxiliary container valves (valve connection style #820, recognized by the Compressed Gas Association as the only acceptable means of connecting to container valves). The external threads on the container valve are used only for securing the protective cap.

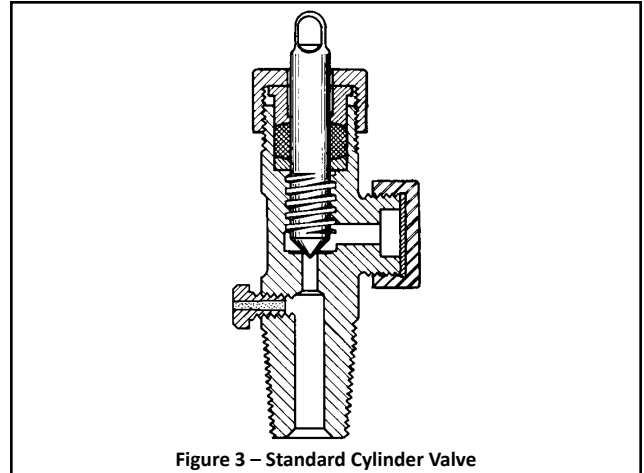

Figure 3 – Standard Cylinder Valve

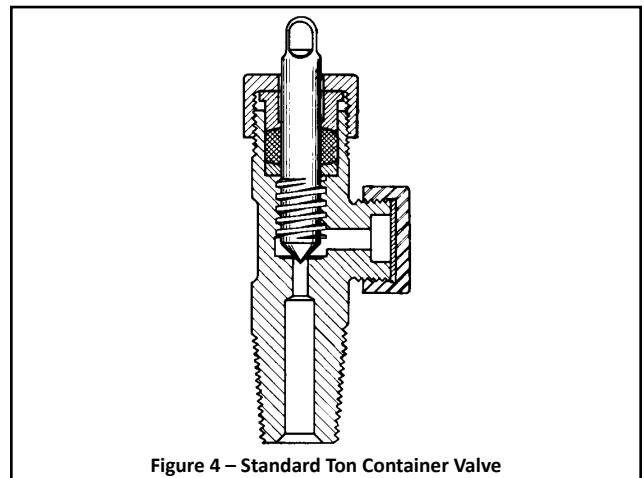

Figure 4 – Standard Ton Container Valve

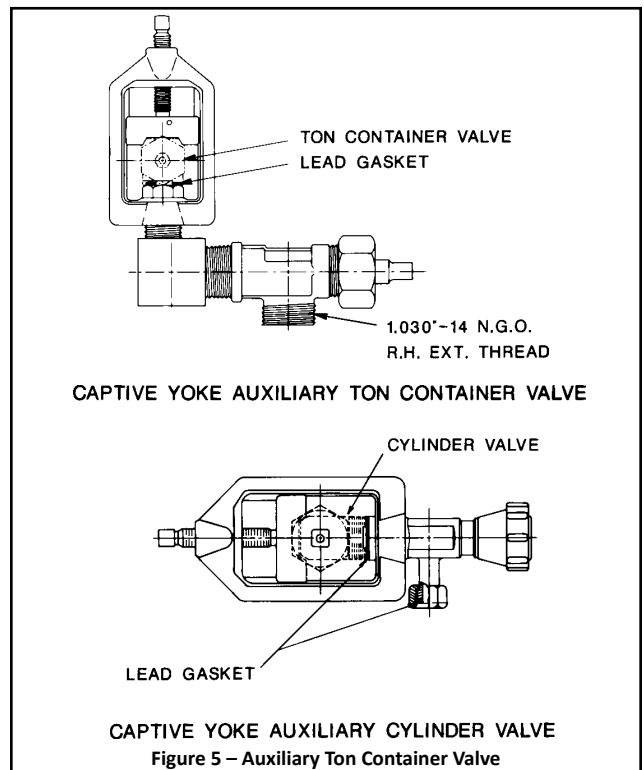

Figure 5 – Auxiliary Ton Container Valve

Cylinders are equipped with one valve that is normally used for gas withdrawal. Ton containers are equipped with two valves, as shown in Figure 6.

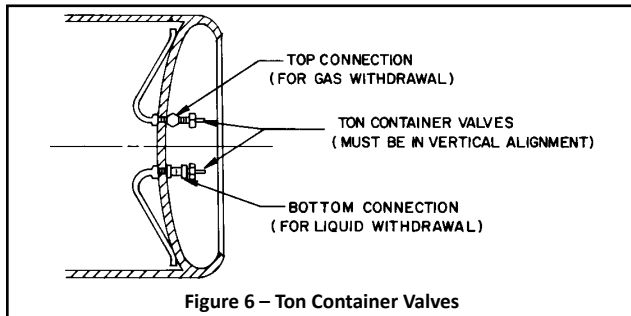

Figure 6 – Ton Container Valves

The upper valve is used for gas withdrawal and the lower valve for liquid withdrawal. Tank cars are equipped with four standard angle valves, as shown in Figure 7.

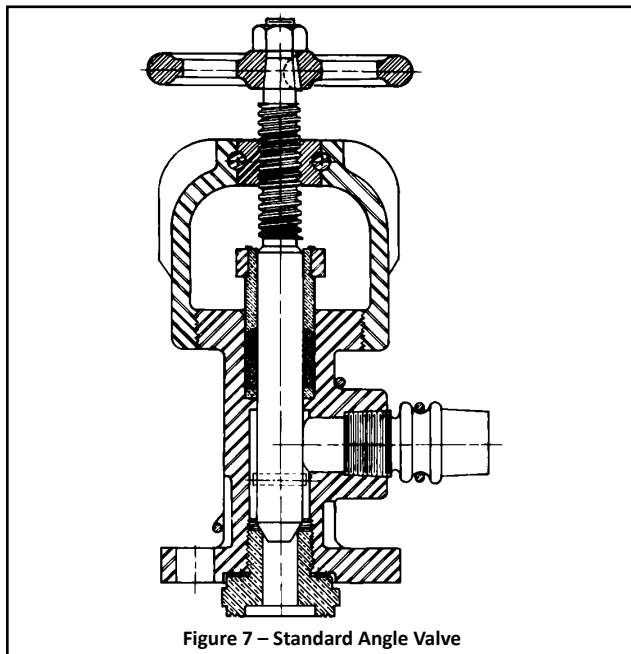

Figure 7 – Standard Angle Valve

Outlet is one-inch female ANSI Standard taper pipe thread. The liquid withdrawal valves are located on the longitudinal center line of the tank car. The valves on the transverse center line are connected to the vapor space and are used to obtain chlorine gas under pressure for testing the piping or for air padding the tank car.

3.4 PRESSURE RELIEF DEVICES

All chlorine supply containers are equipped with some type of device for relief of pressure. Cylinder valves have a fusible metal plug screwed into the body of the valve, as shown in Figure 3. The fusible metal melts when the temperature

increases to 158-165° F to relieve pressure and prevent rupture of the cylinder.

Ton containers are equipped with six fusible metal plugs (see Figure 8), three of which are in each end, spaced 120 degrees apart.

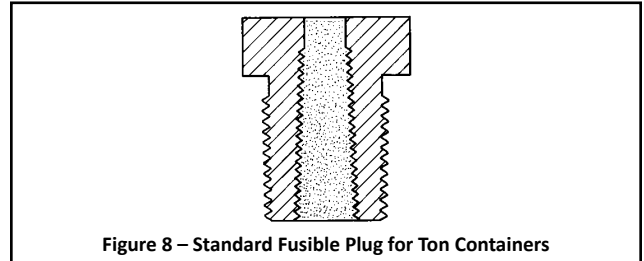

Figure 8 – Standard Fusible Plug for Ton Containers

Tank cars have an excess-flow valve (see Figure 9) located under each liquid valve. While this valve may close during a catastrophic pipe line failure, its main function is to close automatically if the angle valve is broken off in transit. Tank cars also have a pressure relief device (see Figure 10) located in the center of the manway. The relief level varies with the type of car or tank.

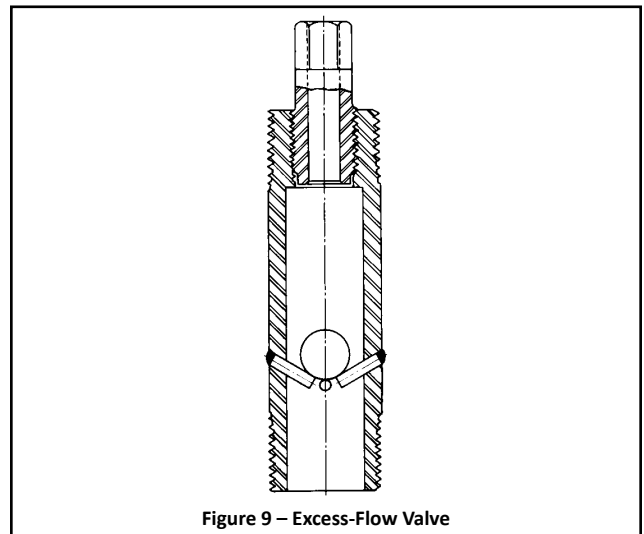

Figure 9 – Excess-Flow Valve

3.5 STORAGE OF CONTAINERS

Store chlorine containers of any type under cover and in cool, well ventilated locations protected from fire hazards and adequately protected from extreme weather conditions. During the summer months, full containers should be shielded from the direct rays of the sun, otherwise a dangerous build-up of pressure might result (see Figure 1 and Paragraph 3.3). If stored out of doors, keep containers in fenced-off areas for protection. Avoid storage in subsurface areas because chlorine is heavier than air and will not readily rise from

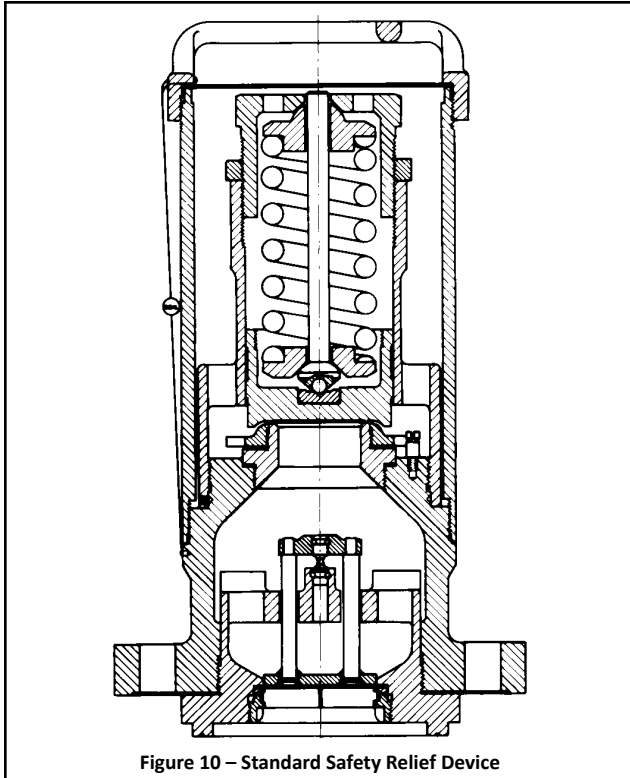

Figure 10 – Standard Safety Relief Device

subsurface locations should leaks occur. Do not store or use chlorine containers near other chemicals or gases.

WARNING: STORE CYLINDERS IN AN UPRIGHT POSITION. TO AVOID SEVERE PERSONAL INJURY OR EQUIPMENT DAMAGE, SUPPLY CYLINDERS MUST BE SECURED IN SUCH A MANNER (E.G., CHAIN) AS TO PREVENT THEIR BEING KNOCKED OVER. TON CONTAINERS MUST BE SECURED IN SUCH A MANNER (E.G., CROCKS) TO PREVENT THEIR ROLLING OUT OF PLACE.

Do not remove the protective cap or hood from cylinders or ton containers until they are ready to be put in actual use. Do not store containers in a heavily traveled area where physical contact damage could occur.

It is essential that areas used to house chlorine containers or equipment be continuously monitored for the presence of chlorine in the air. This may be a requirement of applicable laws and/or regulations.

When containers are moved from a storage area to an area where they will be used, allow sufficient time to stabilize the temperature, and therefore the pressure, of the container and the chlorine before it is used.

The chlorine inventory depends to a large extent on local availability. Consult with chlorine suppliers in the area; review appropriate fire code requirements concerning storage of oxidizing materials and other applicable laws and regulations.

When planning space for stored containers, sufficient space must be allowed for empty containers. The best way to determine the amount of chlorine remaining in a container is to weigh the container continuously on a scale. This also makes it possible to record the amount of chlorine used. Portable or dormant scales in beam, dial, or digital types and with varying platform sizes are available.

WARNING: ALWAYS REMOVE WHEELS AND AXLES OF PORTABLE SCALES SO THAT THE SCALE CANNOT MOVE WHEN CYLINDERS ARE ON THE PLATFORM.

Preferably, scales for cylinders should be installed with their platform flush with the floor to eliminate the necessity of lifting the cylinders. Some low profile scales such as the Wallace & Tiernan® Cylinder Scale are low enough that cylinders can be placed on the scale without lifting. Others are installed with ramps. If scales are pit mounted, a trapped drain should be provided.

Scales for ton containers are usually installed above the floor, since ton containers are usually handled by overhead conveyor. Many of these scales do not have platforms since the ton containers are usually supported by cradles or trunnions.

Special high-capacity scales are provided at some installations using tank cars. These scales are usually pit mounted below the railroad siding with the dial or digital unit housed above ground beside the track.

Some of the dial or digital scales are equipped with loss-of-weight recording systems providing a permanent record of chlorine usage.

3.6 HANDLING CONTAINERS

Always handle chlorine containers with utmost care. To prevent injury or damage, do not drop chlorine containers and do not permit containers to strike each other or other objects. To prevent damage to the valve, valve protecting caps or hoods must always be in place when containers are moved.

Handle cylinders with a simple two-wheel hand truck of the barrel pattern. Hand trucks should be well balanced and equipped with chains or clamps to prevent the cylinders from falling off the truck.

WARNING: NEVER LIFT CYLINDERS BY THE VALVE PROTECTING HOOD. THE HOOD MAY SEPARATE FROM THE CYLINDER, CAUSING THE CYLINDER TO FALL.

Never lift cylinders by sling or magnetic devices. If lifting is necessary, use a specially designed cradle. Contact your chlorine supplier for recommendations or information.

When moving ton containers, due consideration must be given to the fact that the liquid in the container represents a live load in addition to the dead load of the container and the liquid. The most accepted way of moving ton containers is by overhead conveyor and lifting beam (see Figure 11).

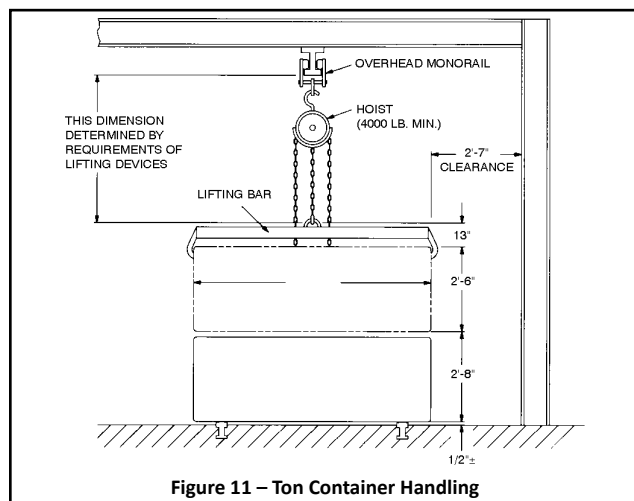

Figure 11 – Ton Container Handling

Rails or roller conveyors have also been used. Fork lift trucks, in addition to having adequate capacity, must have the containers restrained and be sufficiently stable to prevent tipping.

3.7 USING CONTAINERS

If containers have been stored in an area other than that in which they will be used, they should be allowed to stabilize at the new temperature before being used. Containers should always be used in the order in which they are received to avoid unnecessarily long storage and possible difficulty with valves that have not been opened or closed for too long a period.

WARNING: CYLINDERS ARE NORMALLY USED IN AN UPRIGHT POSITION FOR GAS WITHDRAWAL. TO AVOID SEVERE PERSONAL INJURY OR EQUIPMENT DAMAGE, SUPPLY CYLINDERS MUST BE SECURED IN SUCH A MANNER (E.G., CHAIN) AS TO PREVENT THEIR BEING KNOCKED OVER. TON CONTAINERS MUST BE USED IN A HORIZONTAL POSITION WITH THE TWO VALVES IN A VERTICAL LINE. TON CONTAINERS MUST BE SECURED IN SUCH A MANNER (E.G., CHOCKS) TO PREVENT THEIR ROLLING OUT OF PLACE.

When withdrawing gas from a ton container, connection is made to the upper valve (see Figure 6). Liquid withdrawal is accomplished by connecting to the lower valve.

It is recommended that special 3/8-inch square box wrenches, rather than adjustable wrenches, be used for opening cylinder and ton container valves. Length of the wrench should not exceed eight inches. It is good practice to leave the wrench in place so the valve can be closed quickly in case of an emergency. Maximum discharge can be accomplished with one full turn of the valve. Excessive force must not be used in opening valves. Never strike the wrench with anything other than the heel of the hand. Loosening the packing nut a maximum of 1/2 turn is acceptable, provided the packing nut is tightened after the valve is operated. Contact your chlorine supplier if these procedures do not permit operation of the valve.

Angle valves on tank cars must be opened fully to aid the operation of the excess flow valve.

Always test for leaks before putting new containers in service. The system can be pressurized by opening the container valve and then closing it. The valve can be opened again after it is determined that there are no leaks.

WARNING: ALWAYS WEAR PROTECTIVE CLOTHING WHEN CHECKING FOR LEAKS. REFER TO "PERSONNEL SAFETY" FOR INFORMATION ON HEALTH HAZARDS AND SAFETY PRECAUTIONS.

It is not unusual during humid conditions for condensation to collect on the outside of the container. A buildup of frost on the container indicates that withdrawal rates are too high to permit the surrounding air to supply the heat necessary to evaporate the liquid chlorine. Increasing the circulation of room temperature air past the container may correct the condition. Do not apply direct heat to the container in any way. It may be necessary to shut off the container valve and permit it to warm up again before putting it back in service.

After emptying the container, the valve must be closed before disconnecting to prevent the entry of moisture. After disconnecting, the valve cap and the valve protecting cap or hood must be replaced before the container is moved. Empty containers should be segregated from full containers and should be tagged.

Tank cars are unloaded by means of one of the liquid valves. One of the gas valves can be connected to the system to permit pressure testing with gaseous chlorine rather than liquid. The flexible connection used for tank car unloading must be designed for and installed in such a manner to allow for the significant increase in height as the car unloads. Since

tank car pressure is the only force causing the chlorine to discharge, many cars are padded with dry air by the producer or the user. Reference to Chlorine Institute Pamphlet 66, Chlorine Tank Car Loading, Unloading, Air Padding, Hydrostatic Testing, should be made for information on user air padding. It is essential that air padding pressure be kept as low as possible for satisfactory operation of the chlorination equipment since excessive air padding pressures can have a negative impact on evaporator performance. The depletion of the liquid chlorine supply in the car is accompanied by a sharp drop in tank car pressure.

After the angle valve is closed and the discharge line emptied, the piping may be disconnected. The valve outlet plugs should be replaced and the discharge piping capped immediately.

4 PIPING

4.1 PIPING MATERIALS AND JOINTS

If the chlorinator capacity is low enough, the vacuum regulator or the complete chlorinator may be mounted directly on a cylinder or ton container valve, totally eliminating pressure piping. In this case, reference to the equipment instruction book provides all necessary details.

Pressure connections from all chlorine containers are normally made by means of flexible connections made of copper tubing. Use yoke type connections at container valves. The chlorinator or vacuum regulator instruction book should be referred to for details for use of flexible connections along with the required auxiliary cylinder or ton container valves, header valves, and auxiliary header valves (if required).

WARNING: ALWAYS REPLACE FLEXIBLE CONNECTIONS ANNUALLY (OR SOONER IF THERE IS EVIDENCE OF DEGRADATION).

The usual practice for chlorine liquid or gas pressure lines, at the commonly encountered pressures and temperatures at chlorinator installations, is the use of 3/4 or 1.0 inch schedule 80 carbon steel seamless pipe with Class 3000 forged steel fittings; two-bolt flanges (commonly referred to as oval ammonia unions) are also often used. Both screwed and socket welded construction are common. Threaded joints should be made up using litharge and glycerine for permanent joints, white lead or TFE tape for others.

To facilitate maintenance, the number of line valves should be kept to a minimum. Insulation is required only in those cases where it is necessary to prevent chlorine gas lines from becoming chilled, or liquid lines from becoming overheated.

More complete details, along with ASTM and ANSI specifications, can be obtained by referring to Chlorine Institute Pamphlet 6, Piping Systems For Dry Chlorine.

WARNING: TWO COMMON CAUSES OF CHLORINE PIPING LEAKS ARE:

1. RE-USE OF GASKETS. THIS SHOULD NEVER BE DONE. ALWAYS HAVE AN ADEQUATE SUPPLY ON HAND AND ALWAYS USE NEW GASKETS OF THE CORRECT MATERIAL AND SIZE AS IDENTIFIED ON THE EQUIPMENT PARTS DRAWING.

2. IMPROPERLY MADE-UP THREADED PIPE JOINTS. SEE CHLORINE INSTITUTE MANUAL OR PAMPHLET 6 FOR RECOMMENDED PROCEDURE.

4.2 GAS PIPING INSTALLATION REQUIREMENTS

Reliquefaction of a gas should be avoided. If liquid chlorine is carried downstream to the chlorinator or vacuum piping, it may soften the plastic components and affect their structural strength. Liquid can wash any collected contaminants into the vacuum regulator and can also cause erratic surging, freezing, and pressure release, which can damage the diaphragm and control valves. Cold conditions in a gas pipe line (cold to the touch, dripping of water condensed from the atmosphere, frost, ice) are an indication that liquid chlorine is present in the line and is flashing to gas. Refer to the proper guidelines that follow.

It is important to observe the correct temperature conditions in conducting chlorine gas under pressure from the location of the containers to the point of use. To avoid difficulty with reliquefaction of chlorine, pressure piping and control equipment receiving gas under pressure should be at a higher temperature than that of the chlorine containers. In general, a difference of 5° to 10° F is recommended.

Pitch pressure lines uphill from the gas source toward the chlorinators if possible.

Install a pressure reducing valve or the chlorinator vacuum regulator close to, but higher than, the source of gas. The use of a chlorine pressure reducing valve is also recommended in those localities where severe temperature changes are likely to be encountered during a 24-hour period.

It is preferable to run chlorine pressure gas lines overhead through relatively warm areas rather than along the floor or through basement areas where lower temperatures may be encountered. Do not run these gas lines along exterior walls that may be cold in winter months. Do not run pressure gas lines under windows from which cold air descends in winter months.

If the source of gas is one or more ton containers connected to a manifold, install a drip leg of 1.0-inch schedule 80 seamless steel pipe approximately 18 inches long in a tee in the manifold with the lower end capped. Locate the drip leg immediately downstream of the last container connection to intercept the liquid that comes from the ton containers' gas education tubes when initially opened.

Gas may be withdrawn from two or more containers simultaneously provided all containers are at the same temperature. Refer to Paragraph 3.1.

The installation of chlorine gas strainers in pipe lines upstream from pressure reducing valves or vacuum regulators is a common practice. These strainers can also serve as traps for a small amount of liquid chlorine. Figure 12 illustrates a typical strainer.

4.3 LIQUID PIPING INSTALLATION REQUIREMENTS

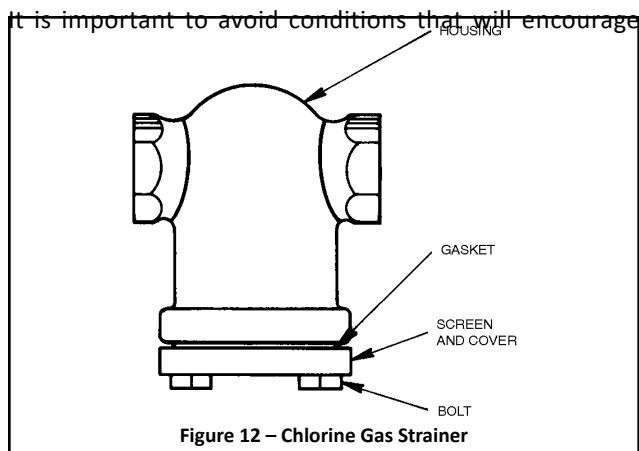

vaporization. Thus it is important to keep liquid chlorine lines as cool as, or cooler than, the containers themselves by eliminating restrictive fittings and always operating with fully opened line valves. Avoid running liquid chlorine lines through overheated areas where gasification is likely.

Valves in liquid chlorine lines should be kept to a minimum. It is particularly important to avoid situations where it is easy to close two valves in a line thus trapping liquid that, upon an increase in temperature, will expand and develop higher than acceptable pressures.

A liquid line pressure relief system (which includes a rupture disc and an expansion chamber) is required where liquid may be trapped in the line or where it is necessary to run lines a considerable distance. The relief system is detailed in Figure 13.

The expansion chamber provides an area for expansion in the event that valves at both ends of the line are closed. Relief system placement must be based not only on length of line but also placement of valves.

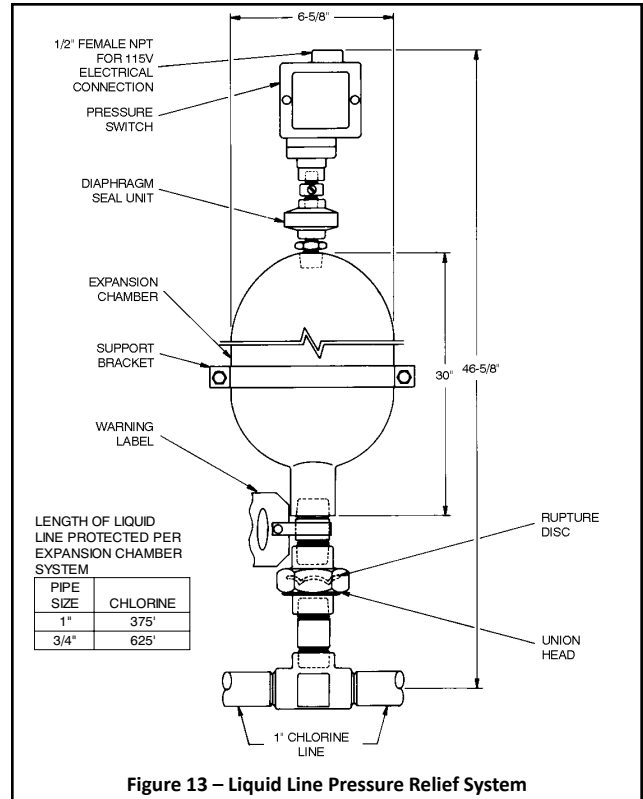

4.4 PRESSURE RELIEF AND VENT PIPING REQUIREMENTS

All pressure relief vent line systems must be treated as though they contain chlorine. Use the same materials for pressure relief vent lines as used for chlorine gas piping, unless the vent line is a combination pressure relief/vacuum relief line in which case the material must be suitable for moist chlorine gas (PVC or polyethylene tubing).

Vent lines must be run in such a way that moisture collecting traps are avoided. A continuous gradient is preferred. The end of all vent lines must be turned down and screened.

Manifolding of vent lines is an acceptable practice provided only like vents are manifolded (i.e., evaporator water vapor vents must be separate from gas pressure reducing valve pressure vents, etc.). The interior cross sectioned area of a common vent or pressure relief line should be approximately equal to the sum of the cross sectional areas of the individual vent lines.

WARNING: THE VENT LINE AND RELIEF LINE MUST TERMINATE IN AN AREA GAS FUMES CANNOT CAUSE INJURY TO PERSONNEL OR DAMAGE. DO NOT TERMINATE THE VENT LINE AND RELIEF LINE AT A LOCATION ROUTINELY USED BY PERSONNEL, SUCH AS WORK AREAS OR PATHWAYS NOR NEAR ANY WINDOWS OR VENTILATION SYSTEM INTAKES. IF AN AREA MEETING THESE REQUIREMENTS IS NOT AVAILABLE, REFER TO THE CHLORINE INSTITUTE'S CHLORINE MANUAL AND PAMPHLET NO. 9 FOR ALTERNATE METHOD OF RELIEF DISPOSAL.

4.5 VALVES

Yoke type auxiliary cylinder, yoke type auxiliary ton container, and header valves are described adequately in the chlorinator or vacuum regulator instruction book.

Line valves are used to isolate alternate sources of supply (manifolded banks of ton containers or tank cars), individual evaporators or pressure type chlorinators. Sufficient line valves should be provided for flexibility of system operation consistent with the recommended practice of eliminating redundant or unnecessary valves.

Valves are usually of approximately globe pattern as shown in Figure 14 or ball type as shown in Figure 15.

Care should be taken that only valves designed by the manufacturer specifically for chlorine service are used. Ball valves must include a provision for venting the cavity in the closed position to the upstream side.

4.6 PRESSURE GAUGES AND SWITCHES

Whenever pressure gauges and switches are used in chlorine liquid or gas lines, they must be of the type protected by a flanged diaphragm seal specifically designed for chlorine service to prevent the entry of chlorine into the gauge or

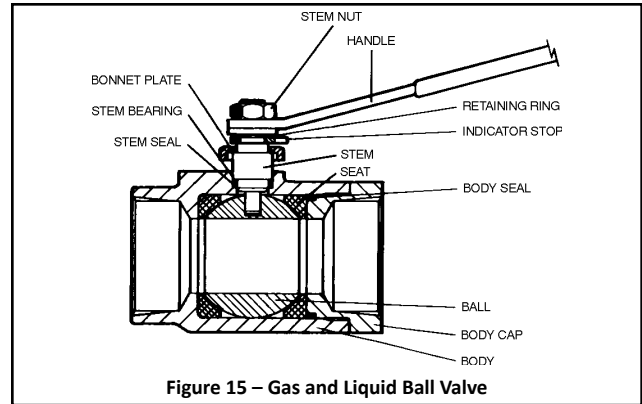

Figure 15 – Gas and Liquid Ball Valve

switch mechanism. The fill material must be suitable for chlorine service. The connection between the seal and the gauge or switch must not be broken. If the connection is inadvertently broken, the complete assembly must be discarded and replaced, unless it can be returned to the manufacturer for repair.

Frequently, valves are installed between chlorine lines and the gauge or switch diaphragm seal to permit removal without taking the line out of service. A means of relieving the pressure in the isolated piping, gauge, or switch is strongly recommended.

WARNING: RELEASING EVEN A SMALL AMOUNT OF LIQUID CHLORINE IS DANGEROUS AND REQUIRES EXTREME CAUTION TO AVOID SEVERE PERSONAL INJURY. ALWAYS USE PROTECTIVE EQUIPMENT WHEN RELIEVING PRESSURE, EVEN IN ISOLATED CHLORINE GAS PIPING.

Since small size line valves for chlorine are not readily available, many times a header valve is used as shown in Figure 16.

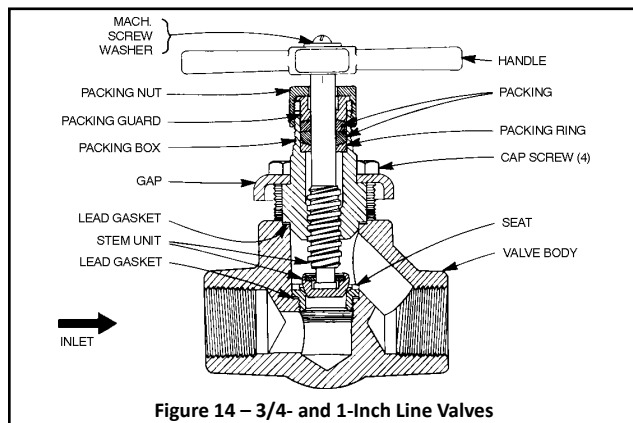

Figure 14 – 3/4- and 1-inch Line Valves

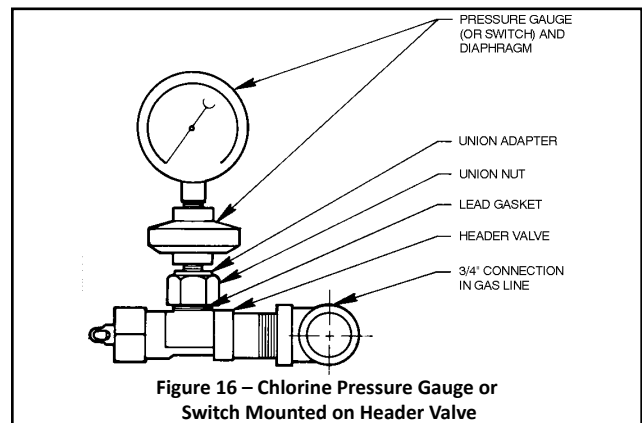

Figure 16 – Chlorine Pressure Gauge or Switch Mounted on Header Valve

4.7 PRESSURE RELIEF DEVICES

There are two types of pressure relief devices in use in chlorine piping systems. The first, as shown in Figure 13, is usually employed in liquid chlorine piping to protect the piping from rupture due to high pressure from thermal expansion of the liquid chlorine. It consists of a rupture disc that ruptures before the pipe line itself can rupture, an expansion chamber that allows for relief of the over-pressure condition without releasing chlorine to the atmosphere, and a pressure switch to warn of the disc rupture.

The second type, as shown in Figure 17, is usually used in gas piping at the evaporator discharge. This system consists of a rupture disc that keeps chlorine out of the valve during normal operation, a pressure relief valve, and a pressure switch to warn of disc rupture.

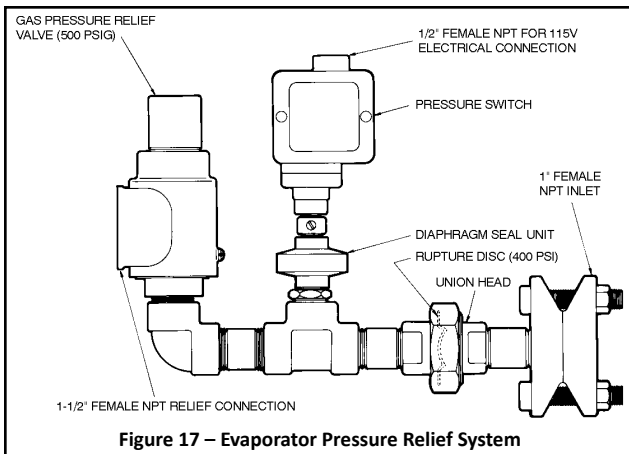

Figure 17 – Evaporator Pressure Relief System

WARNING: THE RELIEF LINE MUST TERMINATE IN AN AREA WHERE GAS FUMES CANNOT CAUSE DAMAGE OR INJURY TO PERSONNEL. DO NOT TERMINATE THE RELIEF LINE AT A LOCATION ROUTINELY USED BY PERSONNEL, SUCH AS WORK AREAS OR PATHWAYS, NOR NEAR WINDOWS OR VENTILATION SYSTEM INTAKES. IF AN AREA MEETING THESE REQUIREMENTS IS NOT AVAILABLE, REFER TO THE CHLORINE INSTITUTE'S CHLORINE MANUAL AND PAMPHLET NO. 9 FOR AN ALTERNATE METHOD OF RELIEF DISPOSAL.

4.8 PREPARATION FOR USE

Normal plumbing practices will result in the entry of cutting oils, greases, and other foreign materials into the piping.

In addition, the line will have been open to the atmosphere during construction, allowing moisture to enter. It is therefore essential that all piping be thoroughly cleaned and dried prior to exposure to chlorine.

WARNING: INCOMPLETE CLEANING CAN RESULT IN VIOLENT REACTIONS BETWEEN CHLORINE AND THESE MATERIALS.

Steam cleaning is an acceptable method for removal of the above materials. Provision must be made for removal of condensate and foreign materials. For alternate methods if steam is not available, refer to Chlorine Institute Pamphlet 6, Piping Systems for Dry Chlorine.

After proper cleaning, all chlorine piping should be hydrostatically tested to one and one half times the expected maximum operating pressure. Prior to testing, all gauges, switches, rupture discs, etc., that could be damaged during testing must be removed and connections plugged. Any moisture absorbing packing or gaskets left in the system during hydrostatic testing must be removed and replaced with new packing or gaskets. After hydrostatic testing, it is essential that all piping be thoroughly dried with inert gas (e.g., nitrogen) or dry air having a dew point of -40° F or below. The dew point of the air or gas leaving the piping must be checked and drying continued until the dew point is at or below -40° F, which may require quite some time.

WARNING: MOISTURE MUST BE REMOVED FROM ANY PART OF THE EQUIPMENT THAT IS NORMALLY EXPOSED TO DRY CHLORINE ONLY. WHILE DRY CHLORINE IS NON-CORROSIVE, MOIST CHLORINE IS EXTREMELY CORROSIVE TO COMMON METALS, SUCH AS BRASS OR STEEL, POSSIBLY RESULTING IN A LEAK AND SEVERE PERSONAL INJURY. ALSO, IF WATER IS TRAPPED IN A SECTION OF PIPING OR EQUIPMENT, SUBSEQUENT HEATING OR FREEZING OF THE WATER MAY RESULT IN HIGH ENOUGH PRESSURE TO RUPTURE THE PIPING OR EQUIPMENT, POSSIBLY CAUSING SEVERE PERSONAL INJURY.

A very acceptable alternate to hydrostatic testing, if proper facilities do not exist for drying, is to test with nitrogen or dry air having a dew point of -40° F or below. The same provision of removing equipment that could be damaged by test pressure applies.

WARNING: TO AVOID SEVERE PERSONAL INJURY, BEFORE PLACING THE PIPING SYSTEM INTO SERVICE, PRESSURE TEST WITH CHLORINE GAS, NOT LIQUID. EACH VOLUME OF CHLORINE LIQUID THAT LEAKS AND THEN EVAPORATES RESULTS IN APPROXIMATELY 460 VOLUMES OF CHLORINE GAS.

The chlorine container valve should be opened only slightly during this phase of testing or preferably closed again after pressurizing the system. The piping should be tested in the smallest sections permitted by the existing valves to minimize

the discharge of chlorine through any leaks.

WARNING: IT IS ESSENTIAL THAT PROPER BREATHING APPARATUS BE AVAILABLE BEFORE CHLORINE IS ADMITTED TO ANY PIPING SYSTEM OR EQUIPMENT. THIS APPARATUS WILL BE DISCUSSED FURTHER UNDER "PERSONNEL SAFETY".

Chlorine leaks are best located using a dauber moistened with commercial 26° Baume' aqueous ammonia (household ammonia is not strong enough) . A white cloud will be formed at the site of any leak. A plastic squeeze bottle that directs ammonia vapor, not liquid, at the joint being tested may also be used.

When a leak is detected, the system must be depressurized before corrective action is taken. The best method of depressurizing the system is through one of the chlorinators. At least one chlorinator must be readily available for this purpose before testing with chlorine begins.

5 PERSONNEL SAFETY

5.1 GENERAL

Proper consideration of personnel safety begins with the provision of properly sized and arranged housing so that operating personnel have adequate room to perform their duties. It is preferable that any room used for chlorine storage or equipment have two doors that open outward and that are equipped with panic bars.

Rooms housing chlorination equipment, and chlorine containers that are "in service" or "in reserve", should be heated when the room temperature falls below 50° F. Comfortable working temperatures of 65° to 75° F are recommended for the chlorine equipment room. The temperature of the chlorine container room (if separate) should normally be 5° to 10° F lower. All common methods of heating are acceptable, provided that care is taken to prevent overheating of chlorine containers. Radiators should not be located adjacent to containers. If space heaters are used, the warm air should be deflected away from the containers. Outside windows should be located or screened so that the rays of the sun do not fall directly on chlorine containers.

Natural ventilation may be adequate for a small chlorinator installation in a separate building when windows and doors can provide cross circulation; however, ventilation by means of a proper type electric fan is always recommended.

In all cases, installations must comply with appropriate regulations.

5.2 HEALTH HAZARDS

Exposure to a sufficiently high concentration of chlorine can result in difficulty in breathing and, if prolonged, finally death through suffocation. Chlorine's strong pungent odor may result in detection at levels as low as 1.0 ppm and most people will detect it by the time the concentration reaches 3.5 ppm. Concentrations of 5 ppm or more are so objectionable that only those who are unconscious or trapped will normally remain in the area. Increasing concentrations will produce eye irritation, coughing, throat irritation, vomiting, and labored breathing.

Even concentrations below the threshold of smell can result in minor eye and throat irritation if the exposure is long enough.

Liquid chlorine can cause burns and/or irritation when it is in contact with the skin or eyes.

Medical attention should be obtained immediately for personnel who have sufficient exposure to result in any symptoms beyond minor irritation. Properly trained and equipped first aid personnel are usually the first line of defense. While waiting for their arrival, the exposed individual must be removed to a safe area and be placed in a comfortable position. If breathing has stopped, artificial respiration must be started immediately. CPR administered by properly trained personnel is required if the heart has stopped.

If the exposed individual has difficulty breathing, oxygen should be administered only by those adequately trained in the procedure and the equipment used.

The proper procedure for emergency treatment of clothing or skin contaminated by chlorine is to flush the area with large quantities of water under a shower for at least 15 minutes. While still under the shower, affected clothing should be removed. No medical treatment or neutralization of the chlorine should be attempted except as directed by a physician.

Immediate flushing with tepid water should be administered if even small quantities of chlorine enter the eye or if the eye has been exposed to strong concentrations of chlorine. The eyelids must be parted and thorough flushing continued for at least 15 minutes. As mentioned previously for skin exposure, no medical treatment or neutralization should be attempted except as directed by a physician.

The attending physician may wish to refer to a Material Safety Data Sheet on chlorine as well as to the Chlorine Institute's Chlorine Manual and/or Pamphlet 63, First Aid and Medical Management of Chlorine Exposures.

5.3 SAFETY PRECAUTIONS

The first steps to be taken in providing proper safety precautions at any facility are the selection of safety equipment to be on hand, the proper location of the equipment, and the training of all personnel in proper procedures to avoid unnecessary chlorine releases and to deal with releases that occur.

Proper respiratory equipment is essential for all facilities regardless of size. For maximum safety, it is preferable to use air tank type pressure demand masks that have a self-contained air supply and, therefore, are suitable regardless of chlorine concentration.

All respiratory equipment must meet the requirements of the National Institute for Occupational Safety and Health. Following the respiratory equipment manufacturer's recommendation regarding maintenance and periodic testing is essential. This equipment should be stored outside the area containing chlorine or chlorine equipment in a manner protecting it from damage of any kind and so as to be readily available.

WARNING: DO NOT LOCK CABINETS OR CLOSETS IN WHICH RESPIRATORY EQUIPMENT IS STORED, AS THE EQUIPMENT MUST BE READILY AVAILABLE.

All personnel with no assigned responsibility for dealing with a chlorine release should be instructed to leave the area. Those responsible for correcting the situation should don respiratory equipment before doing so.

Protective clothing is recommended for handling even routine operations involving chlorine. In the event of a substantial release, protective clothing is required. Anyone desiring further information on protective clothing should refer to the Chlorine Institute Pamphlet 65, Protective Clothing for Chlorine.

Safety shoes, hard hats, and safety glasses should be used in accordance with standard plant practice.

Most leaks will occur in piping, valves, connections, and the pressurized portions of chlorine equipment. These leaks will usually be eliminated by tightening packing, replacing gaskets, or repairing the equipment.

WARNING: REPLACE FLEXIBLE CONNECTIONS ANNUALLY, OR SOONER IF THERE IS EVIDENCE OF DETERIORATION.

Emergency kits (meeting Chlorine Institute requirements) are available that can seal off most leaking areas of chlorine

containers (i.e., valves, fusible plugs, or container wall). If these are on hand they must be used only by personnel thoroughly familiar with their use. The chlorine supplier should be contacted immediately for information, assistance, and advice on the disposition of the leaking container. The container should always be repositioned, if possible, so the leak is gas rather than liquid.

WARNING: NEVER UNDER ANY CIRCUMSTANCE SPRAY WATER ON A CHLORINE LEAK. THIS WILL ONLY MAKE IT WORSE.

Wall charts are available from most chlorine suppliers that provide much of the information contained in this manual.

5.4 EMERGENCY ACTION PLANS

The best emergency plan includes routine practices that are designed to minimize emergencies. Proper maintenance of all equipment associated with the storage, handling, and use of chlorine in accordance with the manufacturer's instructions is essential.

All equipment and piping containing chlorine under pressure must be tested periodically for leaks following procedures covered in Paragraph 4.8. Since it is not unusual for areas used for chlorine storage and chlorine equipment to be relatively unattended, it is important for the air in these areas to be monitored continuously with chlorine detectors, so that warning of leaks is given as early as possible. As with most emergencies, the earliest detection helps to minimize the damage to equipment and personnel. In addition to warning of leaks when the areas are unattended, chlorine detectors should warn of the presence of minor amounts of chlorine that may not be detected by personnel in the area.

Some chlorine leaks are minor but all require immediate attention.

In the event of a major release of chlorine, there should be no delay in contacting the agency in the community that is responsible for handling hazardous material releases. Appropriate names and telephone numbers must be prominently posted.

The chlorine supplier is probably the best source of assistance for most chlorine users. In addition, the Chlorine Institute's Chlorine Emergency Plan (CHLOREP) can provide vital assistance. In the United States this plan is activated through CHEMTREC (toll free 800-4249300). In Canada, contact CANUTEC (call collect 613-996-6666). These names and numbers must also be posted prominently.

The person responsible for making any of the calls listed above must be sure to give the agency contacted complete details including facility name, address, telephone number, and the names(s) of personnel to contact for further information. The description of the emergency should include size of container, corrective action already taken, local weather conditions, injuries, proximity to populated areas, and directions for easiest access to the site.

It is vital that the emergency plan include use of the "buddy system", i.e., no personnel should be allowed to work alone in an area with a chlorine leak even if the second person is only standing by. As indicated earlier, all personnel not involved in locating and correcting the leak should leave the area travelling in a crosswind direction to an area that is upwind and above the leak. Since it may not be possible for all personnel to be equipped with respiratory equipment, they should be instructed to use a wet cloth or handkerchief over the nose and mouth while leaving the area.

Chlorine Institute Pamphlet 64, Emergency Control Planning Checklist for Chlorine Facilities, may be of assistance in preparing the emergency plan. A Material Safety Data Sheet for Chlorine, available from the Institute or the supplier, should also be consulted.

No emergency plan should be implemented until it is reviewed by the chlorine supplier and the agency in the community having responsibility for hazardous material handling and disposal.

If it is apparent that fire will threaten or is present in a chlorine storage area, it is preferable to remove the containers. If this is not possible, the containers must be protected from the heat of the fire by spraying them with water. Do not spray water on any leaking container, however, since water will react with the chlorine, forming acids that will make the leak worse.

5.5 CHEMICAL DISPOSAL FACILITIES

Part of the planning for emergencies entails provision for disposal of any released chlorine. In most cases little can be done about the chlorine already released to the atmosphere except to try to prevent its dissipation into areas where damage to equipment and personnel will result.

At some large installations, scrubbers have been installed so that areas containing chlorine or chlorine equipment can be sealed off and the air removed to a process that will absorb the chlorine. The design of such a system is complex and should only be attempted by those thoroughly familiar with the process.

Absorption systems have been provided at some facilities to permit a leaking container to be emptied quickly if this is deemed essential. One pound of chlorine can be absorbed by 1.4 pounds of sodium hydroxide (caustic soda), 3.7 pounds of sodium carbonate (soda ash), or 1.3 pounds of calcium hydroxide (hydrated lime).

WARNING: TO AVOID SEVERE PERSONAL INJURY WHEN USING CORROSIVE CHEMICALS, OBSERVE ALL SAFETY PRECAUTIONS RECOMMENDED BY THE CHEMICAL MANUFACTURER/ SUPPLIER.

In each case, one pound of the material should be dissolved in one gallon of water. Lime will actually be suspended in, rather than dissolved in, the water and requires constant agitation.

The tank and other equipment provided for an absorption system must be fabricated of materials suitable for the chemicals involved.

Provision must be made for dissolving the chlorine in the alkaline solution in such a way that the solution cannot be sucked back into the container.

Actually the safest way of disposing of the chlorine in the leaking container might be through the chlorination process, particularly if the process can absorb the chlorine at higher than normal rates without creating damage.

It is not generally permissible to ship a container damaged by leak or fire if it contains chlorine. If for some reason this seems necessary, the chlorine supplier must be contacted.