

Wallace & Tiernan[®]
an eVOQUA brand

SFC-PC CONTROLLER

BOOK NO. WT.050.590.003.UA.IM.0814

W3T109635

SFC-PC CONTROLLER

BOOK NO. WT.050.590.003.UA.IM.0211

SFC-PC CONTROLLER

EQUIPMENT SERIAL NO. _____

DATE OF START-UP _____

START-UP BY _____

Prompt service available from nationwide authorized service contractors.

ORDERING INFORMATION

In order for us to fill your order immediately and correctly, please order material by description and part number, as shown in this book. Also, please specify the serial number of the equipment on which the parts will be installed.

WARRANTY

Seller warrants for a period of one year after shipment that the equipment or material of its manufacture is free from defects in workmanship and materials. Corrosion or other decomposition by chemical action is specifically excluded as a defect covered hereunder, except this exclusion shall not apply to chlorination equipment. Seller does not warrant (a) damage caused by use of the items for purposes other than those for which they were designed, (b) damage caused by unauthorized attachments or modifications, (c) products subject to any abuse, misuse, negligence or accident, (d) products where parts not made, supplied, or approved by Seller are used and in the sole judgment of the Seller such use affects the products' performance, stability or reliability, and (e) products that have been altered or repaired in a manner in which, in the sole judgment of Seller, affects the products' performance, stability or reliability. **SELLER MAKES NO OTHER WARRANTY OF ANY KIND, AND THE FOREGOING WARRANTY IS IN LIEU OF ALL OTHER WARRANTIES, EXPRESS OR IMPLIED, INCLUDING ANY WARRANTY OF MERCHANTABILITY OR OF FITNESS OF THE MATERIAL OR EQUIPMENT FOR ANY PARTICULAR PURPOSE EVEN IF THAT PURPOSE IS KNOWN TO SELLER.** If Buyer discovers a defect in material or workmanship, it must promptly notify Seller in writing; Seller reserves the right to require the return of such defective parts to Seller, transportation charges prepaid, to verify such defect before this warranty is applicable. In no event shall such notification be received by Seller later than 13 months after the date of shipment. No action for breach of warranty shall be brought more than 15 months after the date of shipment of the equipment or material.

LIMITATION OF BUYER'S REMEDIES. The **EXCLUSIVE REMEDY** for any breach of warranty is the replacement f.o.b. shipping point of the defective part or parts of the material or equipment. Any equipment or material repaired or replaced under warranty shall carry the balance of the original warranty period, or a minimum of three months. Seller shall not be liable for any liquidated, special, incidental or consequential damages, including without limitation, loss of profits, loss of savings or revenue, loss of use of the material or equipment or any associated material or equipment, the cost of substitute material or equipment, claims of third parties, damage to property, or goodwill, whether based upon breach of warranty, breach of contract, negligence, strict tort, or any other legal theory; provided, however, that such limitation shall not apply to claims for personal injury.

Statements and instructions set forth herein are based upon the best information and practices known to Evoqua Water Technologies, but it should not be assumed that every acceptable safety procedure is contained herein. Of necessity this company cannot guarantee that actions in accordance with such statements and instructions will result in the complete elimination of hazards and it assumes no liability for accidents that may occur.



725 Wooten Road
Colorado Springs, Co 80915

INTRODUCTION

This instruction manual provides the information for installation, operation and maintenance personnel.

This instruction manual is intended for the operating personnel. It contains important information for safe, reliable, trouble-free and economical operation of the unit. Observance of this information helps to prevent hazards, lower repair costs, reduces down-times, and increases the reliability and service life of the unit.

The chapters on installation and maintenance are solely provided for trained service personnel. These sections contain important information on the installation, configuration and commissioning of the unit as well as information on its repair.

All persons working with the unit, must have read and understood the operating instructions, in particular, the safety instructions it contains.

Intended Use

The SFC (Single Function Controller) is exclusively designed for measurement and control tasks required for the treatment of waste water, potable water and industrial water.

The operational safety of the unit is only guaranteed if it is used in accordance with its intended application. The unit may only be used for the purpose defined in the order and under the operating conditions indicated in the technical specifications.

Compliance with the intended use also includes reading this operating manual and observing all the instructions it contains. All inspection and maintenance work must be performed at the prescribed intervals by qualified personnel.

The operator bears full responsibility if this unit is put to any use which does not comply strictly and exclusively with the intended use.

Table Of Contents

| | |
|--|-----------|
| Very Important Safety Precautions..... | SP-1 |
| Regional Offices..... | 1.010-1 |
| Technical Data..... | Section 1 |
| Installation..... | Section 2 |
| Setup and Control Functions..... | Section 3 |
| Operation..... | Section 4 |
| Maintenance..... | Section 5 |
| Spare Parts List..... | Section 6 |

GENERAL SAFETY INSTRUCTIONS

Evoqua Water Technologies attaches great importance to ensuring work on its system is safe. This is taken into account in the design of the system, by the integration of safety features.

Safety Instructions

The safety instructions in this documentation must always be observed. These do not impact any additional national or company safety instructions.

Safety Instructions on the System

All safety instructions attached to the system itself must be observed.

Technical Standard

The system or unit has been constructed in accordance with state-of-the-art technology and the accepted safety regulations. In the event of the system or unit being used by persons who have not been adequately instructed, risks hazard to of such persons or third parties and damage to the system or unit itself or to other property are possible. Work described in this operating manual may only be performed by authorized personnel.

Personnel

The operator of the system must ensure that only authorized and qualified specialized personnel are permitted to work with and on the unit within their defined scope of authority. "Authorized specialists" are trained technicians employed by the operator, by Evoqua Water Technologies, or, if applicable, the service partner. Only qualified electricians may perform work on electrical components.

Spare Parts/Components

Trouble-free operation of the system is only guaranteed if original spare parts and components are used as described in this operating manual. Failure to observe this instruction may incur the risk of malfunction or damage to the system.

Modifications and Extensions

Never attempt to perform any modifications or conversions to the unit without the written approval of the manufacturer.

SFC-PC CONTROLLER

Electrical Power

During normal operation, the control unit must remain closed. Before starting any assembly, inspection, maintenance, or repair work, the system must be switched OFF, and the switch must be secured against reactivation. Connect all cables in accordance with the wiring diagram.

Waste Disposal

Ensure safe and environmentally-friendly disposal of reagents and replaced parts.

WARRANTY CONDITIONS

The following must be observed for compliance with warranty conditions:

- Installation, commissioning by trained and authorized personnel.
- Intended use.
- Observation of the operational parameters and settings.
- The unit may only be operated by trained personnel.
- An operating log book must be kept.
- Only approved calibration chemicals may be used.
- The unit must not be exposed to ambient conditions outside those specified.
- Maintenance work must be executed at recommended intervals.
- Use of original Evoqua Water Technologies spare parts.

If any of the above conditions are not met, the warranty could be void.

SPECIFIC OPERATING PHASES

Normal Operation

Never employ procedures which could affect safety.

Only operate the unit when the housing is closed.

Inspect the unit at least once daily for externally visible damage and faults. Inform the responsible person/authority immediately of any detected changes (including any changes in the operating performance).

In the event of malfunctions, switch the unit off immediately. Have malfunctions remedied immediately.

SFC-PC CONTROLLER

Installation and Maintenance Work

Always perform installation or maintenance work in accordance with this operating manual.

Secure the unit against activation during installation and maintenance work.

Always retighten released screw connections.

Never use corrosive cleaning agents. Use only a damp cloth to clean the unit.

Ensure safe disposal of reagents and replaced parts in accordance with environmental regulations.

SFC-PC CONTROLLER

VERY IMPORTANT SAFETY PRECAUTIONS

This page provides very important safety information related to safety in installation, operation, and maintenance of this equipment.

WARNING

TO AVOID POSSIBLE SEVERE PERSONAL INJURY OR EQUIPMENT DAMAGE, OBSERVE THE FOLLOWING:

ALL USERS OF THIS EQUIPMENT SHOULD BE MADE AWARE OF THE PROBLEMS ASSOCIATED WITH HANDLING HAZARDOUS MATERIALS IN EITHER LIQUID OR GASEOUS FORM AND OF THE EFFECTS OF EXPOSURE TO THEIR FUMES. REFERENCE SHOULD BE MADE TO THE LITERATURE AVAILABLE FROM THE SUPPLIERS OF THESE CHEMICALS, PARTICULAR ATTENTION BEING PAID TO THE INFORMATION AND ADVICE ON PROTECTIVE CLOTHING.

THIS EQUIPMENT IS CONNECTED TO LINE VOLTAGE. IT IS ESSENTIAL THAT THE UTMOST CARE IS TAKEN WHEN WORK IS CARRIED OUT ON EQUIPMENT WHERE LINE VOLTAGES ARE PRESENT. IT IS RECOMMENDED THAT ALL POWER SUPPLIES ARE SWITCHED OFF WHENEVER POSSIBLE.

WHEN DEALING WITH HAZARDOUS MATERIAL, IT IS THE RESPONSIBILITY OF THE EQUIPMENT USER TO OBTAIN AND FOLLOW ALL SAFETY PRECAUTIONS RECOMMENDED BY THE MATERIAL MANUFACTURER.

DO NOT DISCARD THIS INSTRUCTION BOOK UPON COMPLETION OF INSTALLATION. INFORMATION PROVIDED IS ESSENTIAL TO PROPER AND SAFE OPERATION AND MAINTENANCE.

ADDITIONAL OR REPLACEMENT COPIES OF THIS INSTRUCTION BOOK ARE AVAILABLE FROM:

Evoqua Water Technologies
725 Wooten Road
Colorado Springs, CO 80915
Phone: (800) 524-6324

NOTE

Minor part number changes may be incorporated into Evoqua Water Technologies products from time to time that are not immediately reflected in the instruction book. If such a change apparently has been made in your equipment and does not appear to be reflected in your instruction book, contact your local Evoqua Water Technologies sales office for information.

Please include the equipment serial number in all correspondence. It is essential for effective communication and proper equipment identification.

SFC-PC CONTROLLER

REGIONAL OFFICES

INSTALLATION, OPERATION, MAINTENANCE, AND SERVICE INFORMATION

Direct any questions concerning this equipment that are not answered in the instruction book to the Reseller from whom the equipment was purchased. If the equipment was purchased directly from Evoqua Water Technologies, Colorado Springs, CO contact the office indicated below.

UNITED STATES

725 Wooten Road
Colorado Springs, CO 80915
TEL: (800) 524-6324

CANADA

If the equipment was purchased directly from Evoqua Water Technologies, Canada, contact the nearest office indicated below.

ONTARIO

Evoqua Water Technologies Ltd.
2045 Drew Road
Mississauga, Ontario
L5S 1S4
(905) 944-2800

QUEBEC

Evoqua Technologies des Eaux Itée
505 Levy Street
St. Laurent, Quebec
H4R 2N9
(450) 582-4266

SFC-PC CONTROLLER

SECTION 1 - TECHNICAL DATA

List of Contents

| | PARA. NO. |
|---|-----------|
| Versions | 1.1 |
| Specifications..... | 1.2 |
| SFC Electronic Module and Input Modules | 1.2.1 |
| Scope of Supply | 1.3 |
| Standard | 1.3.1 |
| Description | 1.4 |
| Versions | 1.4.1 |
| Design..... | 1.5 |
| SFC Electronic Module..... | 1.5.1 |

1.1 Versions

There are two versions of the SFC.

They differ in the type and number of inputs and outputs that are available and in terms of functionality.

Version 1 (SFC with sensor measuring module)

This analyzer or analyzer/controller supports all applications 1-3 (see section 4.4, "Applications") and is available with or without control capabilities.

- slot for 1 sensor module
- 4 relays
- 2x mA input
- 1x feedback input
- 2x digital input
- 1x temperature input PT 1000
- 1x mA output
- 1x SD card receptacle
- 1x CAN interface
- 1x RS485 interface
- 1x RS232 interface for Gateway
- 1x interface for firmware updates

Version 2 (SFC without sensor measuring module)

This controller supports only applications 3 (see section 4.4, "Applications") without recording measured values via the sensor measuring module. The SFC-SC is a direct proportional controller. The SFC-PC is a compound loop PID controller.

- 2 relays
- 1x mA input
- 1x feedback input
- 2x digital input
- 1x mA output
- 1x interface for firmware updates

1.2 Specifications

1.2.1 SFC Electronic Module and Input Modules

| | |
|-------------------------------|---|
| Dimensions (W x H x D) | 7.3" x 10.4" x 5.7" (185mm x 265mm x 145mm) |
| Weight | approx. 5.5 Lbs (2.5 kg) |
| Protection category | Nema 4X (IP 66), UL, CE |
| Power supply | 100 - 240 VAC \pm 10%, 50 - 60 Hz, 15 W Fuse 1A (T) Type: TR5 or 24 VDC \pm 20%, 15 W Fuse 1A (T) Type: TR5 |
| Operating conditions | Ambient temperature: 0 to 50 °C (32 to 122 °F) Environment: No direct sunlight Atmospheric pressure: 11 to 15 PSI (75 to 106 kPa) Storage temperature: 4 to 158 °C (-20 to 158 °F) Noise emission: <45 dB |
| Digital inputs | 2 x for floating contact (< 100 Ohm) Power supply through SFC (12 V) D1: Sample water flow switch / freely selectable in menu D2: Freely selectable in menu |
| Measurement inputs | 1 x feedback input <ul style="list-style-type: none"> • Positioner position feedback • Potentiometer 1 kOhm or 5 kOhm, 0 - 1 V, 0 - 20 mA (selectable using DIP switch) 1 x mA/V input (electronically isolated up to 50 V to ground) plug-in cards for measured value input from external analyzer 1 x mA input for flow rate 0 - 20 mA / 4 - 20 mA 1 x mA input for external setpoint or dosing factor 0 - 20 mA / 4 - 20 mA (not available with analyzer only version) |

SFC-PC CONTROLLER

| | |
|---|--|
| Interfaces | 1 x RS232 for firmware upload (not electronically isolated) <ul style="list-style-type: none">• ChemWeb-Server• OPC Server Data Access V2.0• CMS Software 3.0• SECO-S7 *The RS485 interface is electronically isolated up to 50 V to ground |
| Display and operating unit | 1 x Operating panel with 9 keys 1 x Graphics display - Resolution 128 x 64 pixels and White background illumination |
| Relay | 2 relay outputs (each with two-way switch) Switching values 5 A, 250 V AC, 1250 VA max. 5 A, 220 V DC, 150 W max. UL/CSA-rating - 5 A, 1/6 HP 125, 250 V AC 5 A, 30 V DC, 30 W max. 1 A, 30 V DC - 0.25 A, 125 V DC |
| mA output | 1 x ma output (freely configurable): Outputs 0/4 - 0-20mA Accuracy < 0.5 % FS Load max. 500 Ohm Temperature drift max. 0.2 % / 10 °C Load monitoring Electrically isolated up to 50 V to ground |
| Memory card | 1 x SD memory card slot for installing an SD memory card |
| mA/V measuring module for analog input | |
| Sensor input: | mA signal or V signal |
| Temperature drift: | max. 0.2% / 10k |
| Linearity error: | < 0.1% |
| Calibration: | Pre-calibrated |
| Measuring ranges: | 0/4 to 20 mA (scalable) or 0 to 10 V (scalable) |

1.3 Scope of Supply

1.3.1 Standard

Depending on the individual order, the scope of supply includes the following:

Electronic module SFC
including accessories set and mounting set, comprising of:

- 4x screws \varnothing 5mm
- 4x dowels \varnothing 8mm
- 4x washers
- 3 multiple seal inserts 2x6mm
- 3 multiple seal inserts 4x5mm
- 3 reducing sealing rings \varnothing 8mm
- 4 bolts for multiple seal inserts 5mm
- 2 bolts for multiple seal inserts 6mm
- DIN rail

1.4 Description

1.4.1 Versions

SFC (Single Function Controller)

The SFC-PC is available in two different voltage variations:

- 100 to 240 VAC
- 24 VDC

1.5 Design

1.5.1 SFC-PC Electronic Module

The SFC-PC electronic module consists of a plastic housing with a removable cover.

The housing contains:

- IC board
- Housing ducts for the cables of the sensor measuring modules
- the cable glands
- the mA/V input module

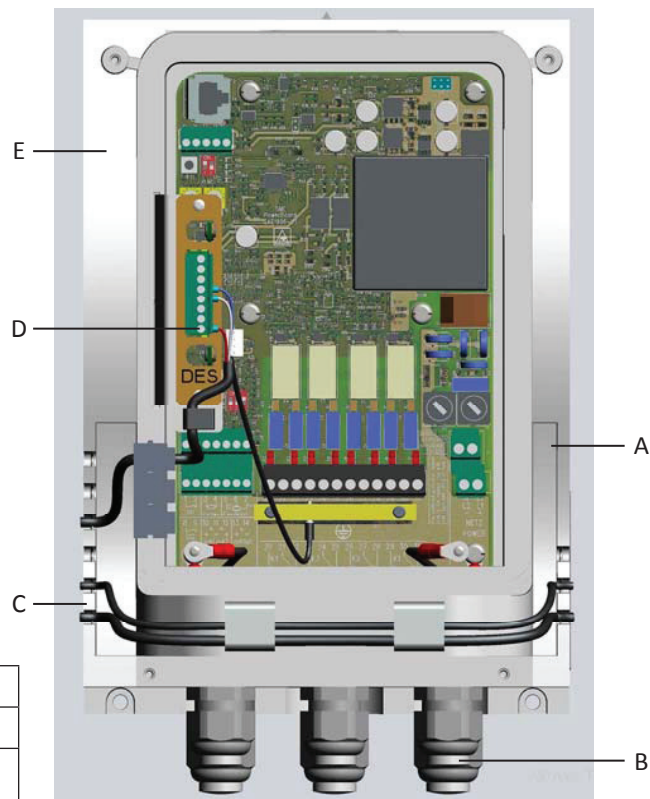

| | |
|---|--|
| A | IC board |
| B | Cable glands |
| C | Housing ducts for the cables of the sensor measuring modules |
| D | Slot for mA/V input module |
| E | Housing |

Figure 1.1 - SFC basic with card and cable

SFC-PC CONTROLLER

The following are integrated into the cover:

- Front panel board with graphic display and interface connections
- Insertable strips
- SD memory card slot - card not included

| | |
|---|-------------------|
| A | Housing cover |
| B | Front panel board |
| C | Insertable strips |
| D | Memory card slot |

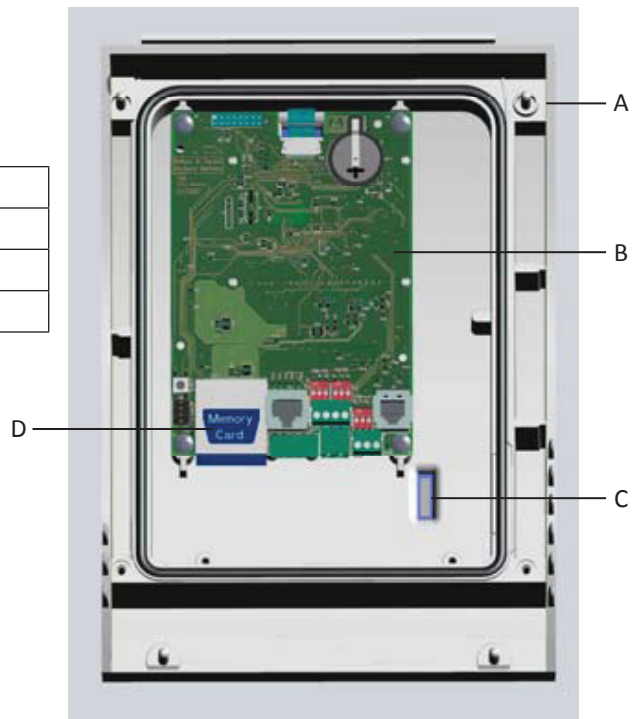

Figure 1.2 - SFC operating front (rear)



SFC-PC CONTROLLER

SECTION 2

SFC-PC CONTROLLER

SECTION 2 - INSTALLATION

List of Contents

| | PARA./DWG. NO. |
|--|-------------------|
| Transport and Storage | 2.1 |
| Transport | 2.1.1 |
| Storage | 2.1.2 |
| Installation | 2.2 |
| Opening the Housing..... | 2.2.1 |
| Installation with Mounting Rail | 2.2.2 |
| Installation without Mounting Rail..... | 2.2.3 |
| Commissioning | 2.3 |
| Installation Guide | 2.3.1 |
| Insert the Sensors and Connect | 2.3.2 |
| Mounting the Housing Covers..... | 2.3.3 |
| Switching the Device On..... | 2.3.4 |
| Setting the Applications | 2.3.5 |
| Positioner Calibration with Compound Loop and Single Feedback Closed Loop with Control | 2.3.6 |
| Positioner Calibration with SFC (Application 3) or Ratio Control (Application 2) | 2.3.7 |
| System Shut Down..... | 2.4 |
| Illustrations | |
| Dimensions | |
| Top Hat Rail Assembly, SFC Controller | 50.590.100.090 |
| Wall Mount Assembly, SFC Controller | 50.590.100.100 |
| Schematic Wiring - SFC | 50.590.155.030A-D |
| Installation Wiring | |
| Connecting SFC to Motor Controlled Actuators Used With V10K and S10K Gas Feeders; Encore® 700 and Chemtube Series Metering Pumps | 50.590.130.010 |
| Connecting SFC to Motor Controlled Actuators Used With V-2000 Gas Feeders..... | 50.590.130.020 |
| Connecting SFC to Pulse Controlled Device | 50.590.130.030 |
| Connecting SFC to Motor Controlled Actuators Used With V-75, V-100 and V-500 Gas Feeders | 50.590.130.040 |
| Connecting SFC to Motor Controlled Actuators Used With 44 Series Metering Pumps | 50.590.130.050 |
| Connecting SFC to Motor Controlled Actuators Used With Series 43-300 HATD Pumps..... | 50.590.130.060 |

SFC-PC CONTROLLER

List of Contents (Cont'd)

| | PARA./DWG. NO. |
|--|----------------|
| Installation Wiring (Cont'd) | |
| Module Mounted SFC Controller | |
| V-2000 Module Mounted Gas Feeder..... | 50.590.130.070 |
| Remote Mounted SFC Controller | |
| V-2000 Module Mounted Gas Feeder..... | 50.590.130.080 |
| SFC Controller in Wall Mounted | |
| V-2000 Gas Feeder..... | 50.590.130.090 |
| Remote Mounted SFC Controller | |
| V-2000 Wall Mounted Gas Feeder | 50.590.130.100 |
| Panel Mounted SFC Controller | |
| LVN-2000 Liquid Chemical Feed System | 50.590.130.110 |
| Remote Mounted SFC Controller Without Junction Box - LVN-2000 Liquid Chemical Feed System..... | 50.590.130.120 |
| Remote Mounted SFC Controller With Junction Box - LVN-2000 Liquid Chemical Feed System..... | 50.590.130.130 |

2.1 Transport and Storage

2.1.1 Transport

The unit is supplied in standard packaging. During transport the packaged unit must be handled carefully and should not be exposed to wet weather or moisture.

Check that the transport packaging is undamaged. In the event of damage please inform the transport company immediately.

If the device is damaged, please contact the respective Evoqua Water Technologies agency immediately. Keep the packing until the unit has been correctly installed and put into operation.

2.1.2 Storage

Store the unit and the sensors in a dry condition without any residual water in a dry place. Storage temperature, see section 1.2, "Specifications".

2.2 Installation

The device must be protected against rain, frost and direct sunlight and should not be installed outdoors. It must be mounted horizontally on a flat wall with an ambient temperature of 32 to 122 °F (0 to 122 °C). The air in the room should be non-condensing.

2.2.1 Opening the Housing

1. Remove the housing cover of the flow block assembly, by lightly pressing the two buttons on the top of the housing (optional).
2. Loosen the four screws on the cover of the SFC electronic module.



CAUTION: The indication and operator controls on the cover of the SFC electronic module are connected to the housing with strain relief cables.

3. Carefully remove the cover of the SFC electronic module and leave to hang on the strain relief cables.

2.2.2 Installation with Mounting Rail (see drawing 50.590.100.090)

1. Fasten the mounting rail to the wall with two screws.
2. Hook the electronic module onto the mounting rail so that it is flush to the right and fasten to the wall with two screws.

2.2.3 Installation without Mounting Rails (see drawing 50.590.100.100):

The modules can be hooked onto suitable tallow-drop screws by the top holding fixtures instead of onto the mounting rail. Proceed with the installation as described above.

2.3 Commissioning

2.3.1 Installation Guide

Commissioning procedure:

When the unit has been mounted, the sensor measuring module can be equipped (not applicable to unit version 2). The electrical connections can then be setup in accordance with the required application. To set applications, refer to section 2.3.11, "Setting the Applications".

The following table contains the individual commissioning steps in their correct sequence. More detailed information is contained in the chapters listed in the "Chapter Referece" column.

NOTE: If this installation sequence cannot be complied with, please contact you Evoqua Water Technologies service department.

SFC-PC CONTROLLER

Commissioning using the example of application 2:

| Sequence | Task | Section | Completed |
|----------|---|-----------------|--------------------------|
| 1 | Open housing cover | 2.2.1 | |
| 2 | Setup electrical connection in accordance with the application. | Wiring Diagrams | <input type="checkbox"/> |
| 3 | Install mA/V module | 2.3.2 | <input type="checkbox"/> |
| 4 | Close the housing cover | 2.3.3 | <input type="checkbox"/> |
| 5 | Switch the unit on | 2.3.4 | <input type="checkbox"/> |
| 6 | Set the language | 2.3.4 | <input type="checkbox"/> |
| 7 | Set the application | 2.3.5 | <input type="checkbox"/> |
| 8 | If another operating mode is activated, switch to "Manual" | 4.3.1 | <input type="checkbox"/> |
| 9 | Set the time | 4.3.1 | <input type="checkbox"/> |
| 10 | Set the date | 4.3.1 | <input type="checkbox"/> |
| 11 | Enter system name | 4.3.1 | <input type="checkbox"/> |
| 12 | Set the trend graphs assignment | 4.3.1 | <input type="checkbox"/> |
| 13 | Set module descriptions | 4.3.1 | <input type="checkbox"/> |
| 14 | Select control mode | 4.3.1 | <input type="checkbox"/> |
| 15 | Set dosing output, and adjust positioner running time, Tp, and max. pulses if necessary | 4.3.1 | <input type="checkbox"/> |
| 16 | On positioner with feedback calibrate Ym | 2.3.6 | <input type="checkbox"/> |
| | With feedback signals, such as mA signal, 0-1V, 5kOhm, the DIP switch S4 must be adjusted on the IC board. Factory setting: 1kOhm potentiometer | 2.3.6 | |
| 17 | Check setpoint and dosing factor, adjust if necessary | 4.3.1 | <input type="checkbox"/> |
| 18 | Check setpoint and dosing source, adjust if necessary | 4.3.1 | <input type="checkbox"/> |

SFC-PC CONTROLLER

| Sequence | Task | Section | Completed |
|----------|--|---------|--------------------------|
| 19 | Check flow rate source, adjust if necessary | | <input type="checkbox"/> |
| 20 | Check flow rate direction, adjust if necessary | | <input type="checkbox"/> |
| 21 | Check control variable 2, adjust if necessary (ratio control only) | | <input type="checkbox"/> |
| 22 | Check X direction, adjust if necessary (ratio control only) | | <input type="checkbox"/> |
| 23 | Check X factor, adjust if necessary (ratio control only) | | <input type="checkbox"/> |
| 24 | Adjust values for Xp and Tn on control loop (single feedback closed-loop control only) | | <input type="checkbox"/> |

NOTE: These values may be optimized later by adaption or manually.

| Sequence | Task | Section | Completed |
|----------|---|---------|--------------------------|
| 25 | Adjust values for Tconst and Tvar on control (combi-control only) | | <input type="checkbox"/> |
| 26 | Check max. Lin. corr., adjust if necessary (combi-control only) | | <input type="checkbox"/> |
| 27 | Check control factor, adjust if necessary (Combi-control only) | | <input type="checkbox"/> |
| 28 | Check Yout factor, adjust if necessary | | <input type="checkbox"/> |
| 29 | Check measuring range, adjust if necessary | | <input type="checkbox"/> |
| 30 | Check limit values, adjust if necessary | | <input type="checkbox"/> |
| | Input and output settings: | | |
| 31 | Check flow rate signal settings such as signal, unit, factor, format, measuring range start and end value, adjust if necessary | | <input type="checkbox"/> |
| 32 | Check flow rate limit values, adjust if necessary | | <input type="checkbox"/> |
| 33 | Check external set point/dosing factor setting such as signal and factor, adjust if necessary (only if using an external set-point/dosing factor) | | <input type="checkbox"/> |

SFC-PC CONTROLLER

| Sequence | Task | Section | Completed |
|----------|---|---------|--------------------------|
| 34 | Check limit values for external set point/dosing factor, adjust if necessary (only if using an external setpoint/dosing factor) | | <input type="checkbox"/> |
| 35 | Check mA signal, adjust if necessary (only if mA output is used) | | <input type="checkbox"/> |
| 36 | Check mA allocation, adjust if necessary (only if mA output is used) | | <input type="checkbox"/> |
| 37 | Check settings for digital inputs 1-2, adjust if necessary | | <input type="checkbox"/> |
| 38 | Configure RS485 interface as required | | <input type="checkbox"/> |
| 39 | Configure CAN interface as required | | <input type="checkbox"/> |
| 40 | Check function of alarms 1-4, adjust if necessary | | <input type="checkbox"/> |
| 41 | Configure alarm 1-4 assignment as required | | <input type="checkbox"/> |
| 42 | Via Mode-Man.Dos, check that all connected actuators and dosing pumps are working properly | | <input type="checkbox"/> |
| 43 | Switch to operating mode "Auto" | | <input type="checkbox"/> |

SFC-PC CONTROLLER

2.3.2 Insert the mA/V Input Card and Connect

Arrangement of the plug-in cards and cables:

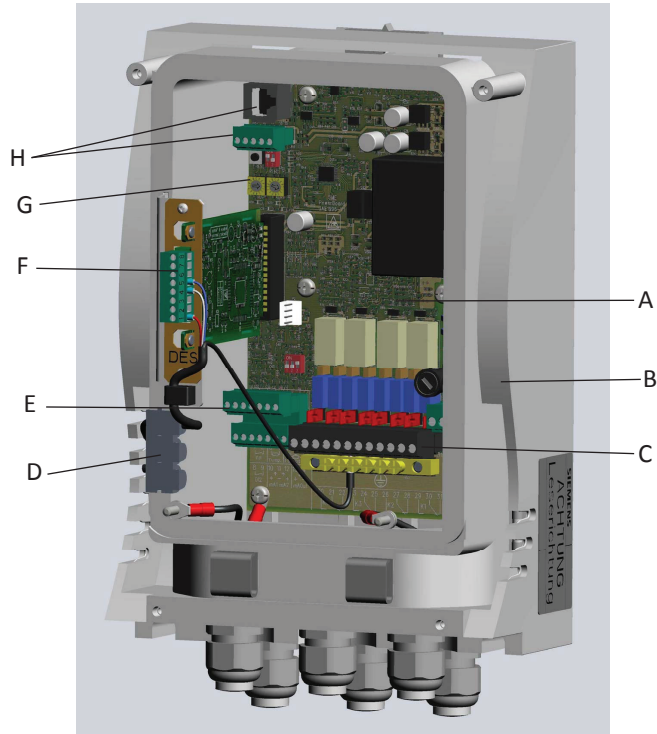

| | |
|---|--|
| A | IC board |
| B | Housing |
| C | Relay terminal |
| D | Sensor cable duct |
| E | Terminal signal inputs/outputs |
| F | mA/V input module |
| G | Coding switch IC board |
| H | Connecting plug or terminal at the front panel board |

Figure 2.1 - Electronic Module Cutaway

NOTE: The coding switch of the IC board may not be changed. If changed, proper function of the SFC can no longer be guaranteed. The settings must remain as shown on the following figure.

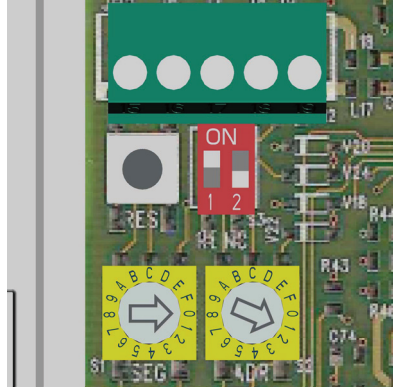

Figure 2.2 - Settings View

2.3.3 Mounting the Housing Covers

1. Ensure that the cable bushes are fitted correctly.
2. Carefully fit the housing cover of the electronic module and secure with the four housing screws.
3. Carefully place the housing cover onto the flow block assembly and snap into place.

2.3.4 Switching the Device On



WARNING: THE DEVICE IS NOT EQUIPPED WITH A MAINS SWITCH AND IS IN OPERATION AS SOON AS THE SUPPLY VOLTAGE IS APPLIED. WHEN ENTERING OPERATING DATA IT MUST BE TAKEN INTO ACCOUNT THAT THESE COULD DIRECTLY INFLUENCE THE CONNECTED SYSTEM COMPONENTS.

Activate the power supply to the device.

The following appear in succession on the graphic display.

During the first commissioning, the language setup menu always appears first. Open the menu with the "Enter" key and set the required language using the up and down arrow keys. Then press "Enter" to confirm the selection. When the country language is set, this screen is no longer shown.

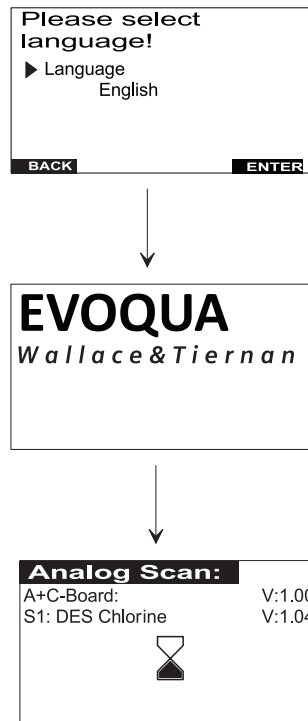

Figure 2.3 - Basic display in main menu

2.3.5 Setting the Applications

- Starting from the basic display, restart the system by selecting “Reset” under the “System” menu, and then selecting “System Restart” ... “Yes”. “Evoqua Wallace & Tiernan” appears.

When this appears, press the "left" and "right" arrow keys simultaneously for at least two seconds, in order to obtain the display of the softkey "APPLIC".

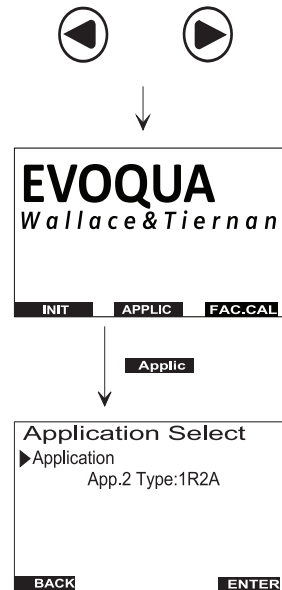

Figure 2.4 - Application selection

- Select the “APPLIC” softkey. The “Application Select” menu appears.
- Select the set application with the “ENTER” softkey.
- Another application can now be set with the “Up” or “Down” arrow keys (see section 3.4, Applications).
- Select “ENTER” to program the set application. Select “BACK” to return to the basic display.

2.3.6 Positioner Calibration with Compound Loop Control and Single Feedback Closed Loop Control

Only possible with selection of "El.Pos.w.Ym".

Automatic calibration:

1. Ensure that the feedback signal is correctly set on the IC board (factory setting 1kOhm potentiometer) see section 3.12, "Actuator Feedback".
2. Starting with the basic display in the main menu, open the "Dosing" window from the "Module Type" menu.
3. Select the parameter "Act. Calibr. Auto" and confirm the selection.
4. Select the "Auto" function and confirm the selection. Feedback signal alignment starts automatically.

The motor moves to the end positions $Y_m = 100\%$ and $Y_m = 0\%$. The end of the alignment is indicated by the message, "YM calibration was complete". If an error occurs during automatic setting, an error is indicated and the setting is terminated.

5. Determine the running time of the positioner from 0% to 100%.
6. Enter the determined running time in the "Dosing" window under Ty.

NOTE: If automatic alignment is not successful, perform alignment manually.

Manual calibration:

1. Starting with the basic display, open the „Dosing“ window from the "Module Type" menu.
2. Select and confirm the parameter "Act.Calibration.Manual“.
3. Open the "000%" menu with the Enter key and close the positioner using the arrow-down key until the limit switch turns off.
4. Save with the Enter key.
5. Open the "100%" menu with the Enter key and open the positioner using the arrow-up key until the limit switch turns off.
6. Save with the Enter key.

NOTE: There must be a distance of at least 60 % of the total path between the set 0% position and the 100% position.

7. Check the position in a second operation:

Select the "MANUAL" operating mode. Move to various positions via the "MAN.DOS" key and check dosing capacity. Repeat calibration at 0% and 100%, if necessary.

8. Determine the running time of the positioner from 0% to 100%.

9. Enter the determined running time in the "Dosing" menu under Ty.

2.3.7 Positioner Calibration with SFC (Application 3) or Ratio Control (Application 2)

In these applications the linearization of the control output is possible, such as for example with a gas feeder which has positioner feedback. Here, for example, 30% control (opening) does not equal 30% dosing capacity. Calibration of the positioner feedback allows up to eleven dosing capacity points to be aligned, in order to obtain dosing that is as linear as possible.

For this purpose, the number of support points to be calibrated can be selected in the "Dosing" menu - "Ym Calib.Points". It is possible to calibrate 2, 3, 6 or 11 support points. The more support points are selected, the more accurate is the dosing.

- Starting from the basic display, select the „Dosing“ menu.
- In the "Ym Calib.Points" menu, select the number of calibration support points.
- Select the "Act.Calibration.Man" menu and confirm with the Enter key.
- The dosing outputs to be calibrated are shown on the display (max. 11).

000% 0.0 (calibration point 0% dosing)

020% 20.0 (calibration point 20% dosing)

040% 40.0 (calibration point 40% dosing)

060% 60.0 (calibration point 60% dosing)

080% 80.0 (calibration point 80% dosing)

100% 100.0 (calibration point 100% dosing)

The calibration points can be selected using the up/down arrow keys. Press Enter to calibrate the support points, and use the up/down arrow keys to open/close the positioner until the actual dosing shown on the dosing capacity indicator (e.g. gas feed inspection glass) agrees with the calibration point (e.g. 20%). Save the value by pressing the Enter key.

- Select the next calibration point and align the actuator position as described.

NOTE: All calibration points must be aligned or checked in order to obtain linear dosing output.

2.4 System Shut Down



CAUTION: Danger of uncontrolled dosing of chlorine or pH correction medium: Shut down dosing system, close positioner!

1. Switch off the power supply.

SFC-PC CONTROLLER

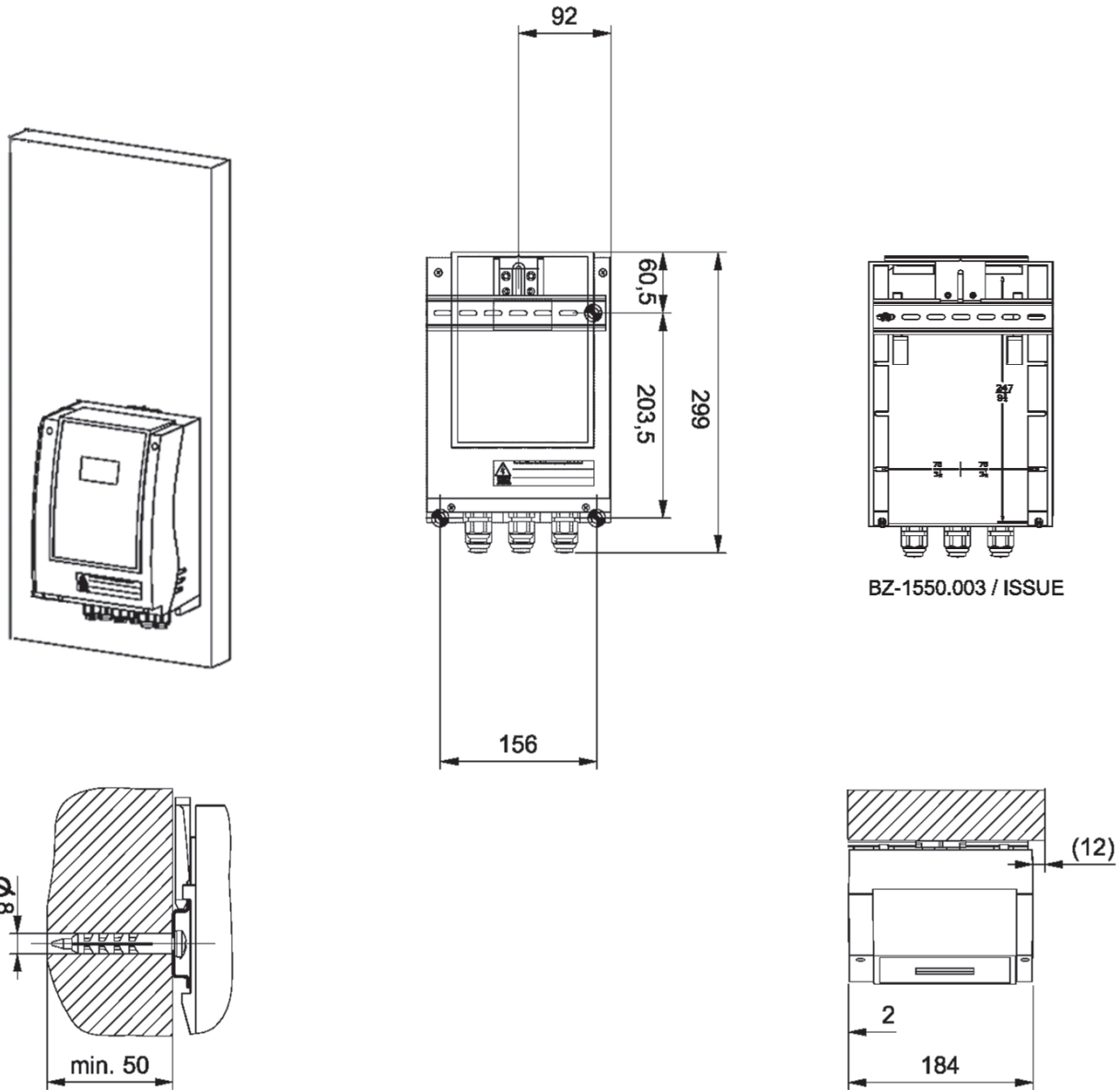

TOP HAT RAIL ASSEMBLY - DIMENSIONS

50.590.100.090

ISSUE 0 7-09

SFC-PC CONTROLLER

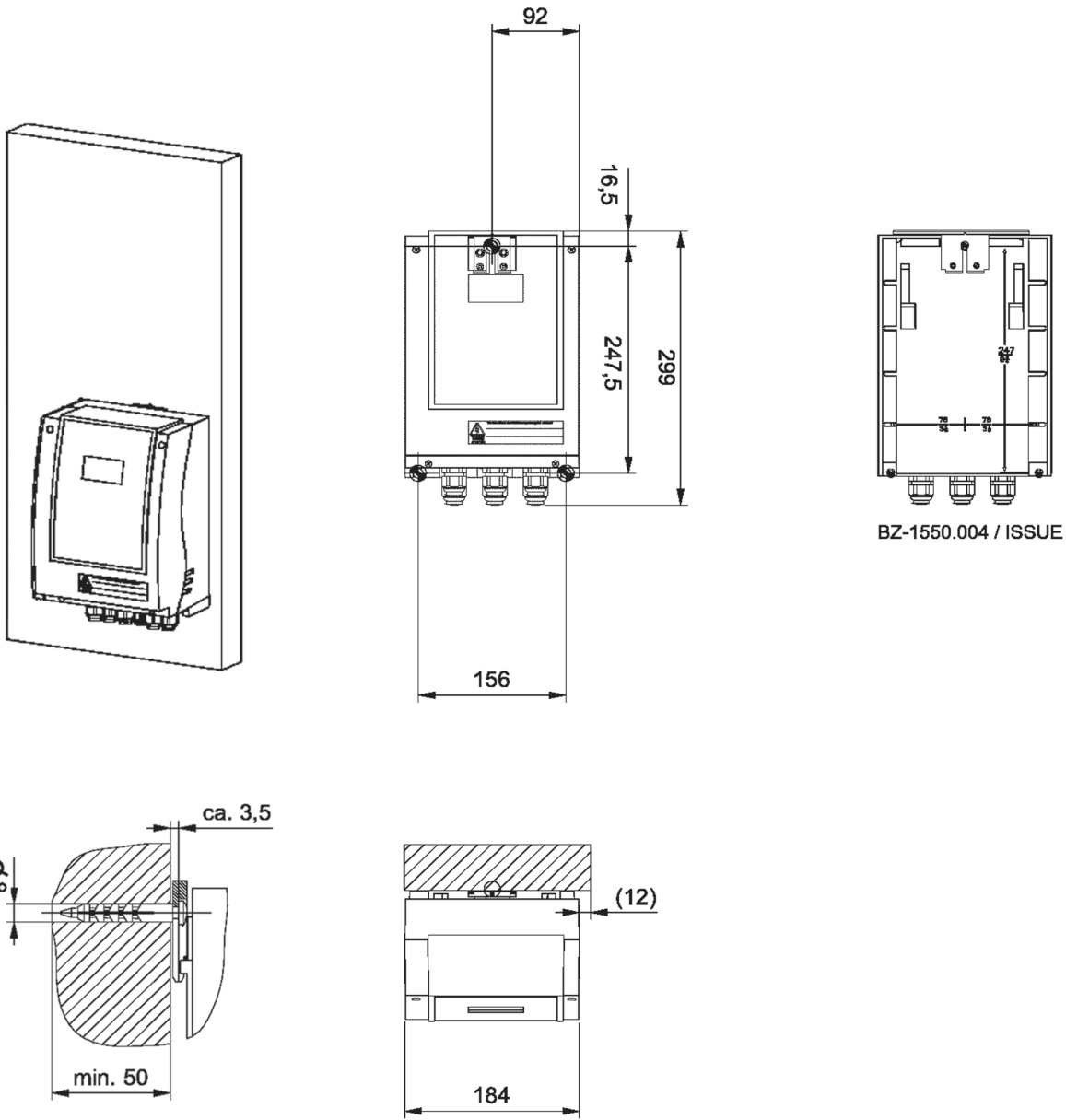

BZ-1550.004 / ISSUE

WALL MOUNT ASSEMBLY - DIMENSIONS

50.590.100.100

ISSUE 0 7-09

SFC-PC CONTROLLER

IC-Board (Mother board)

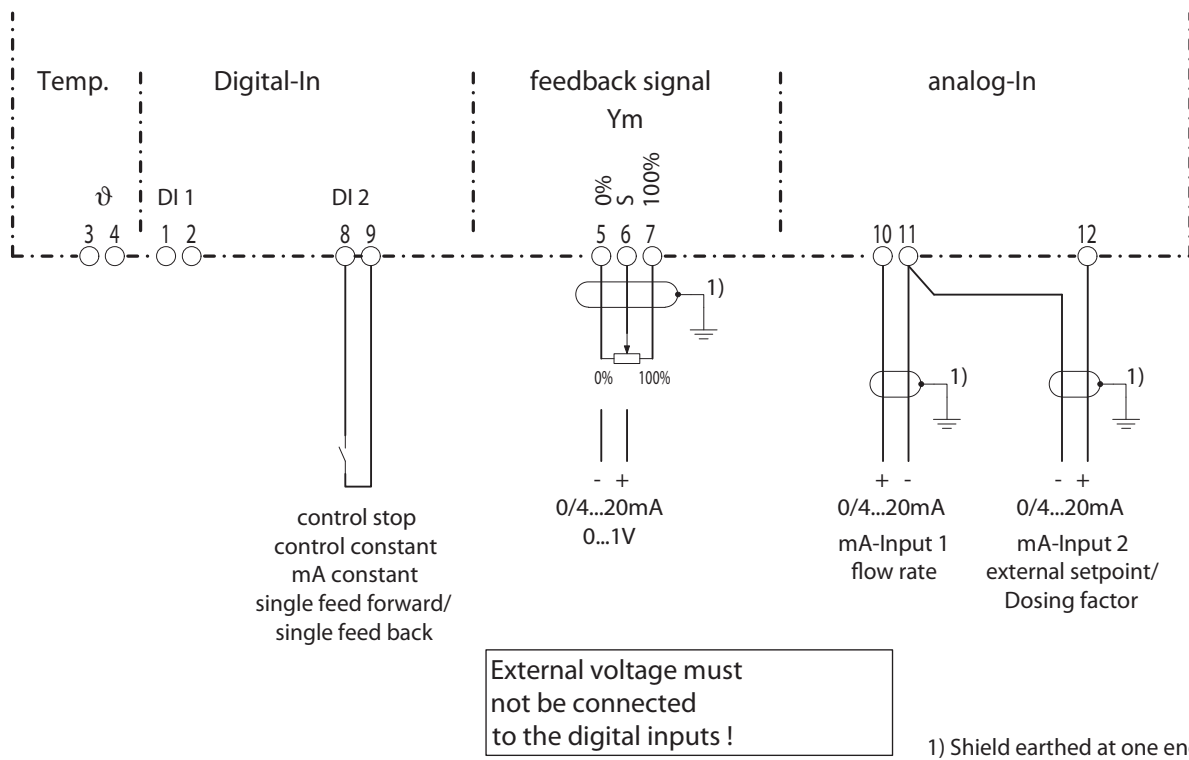
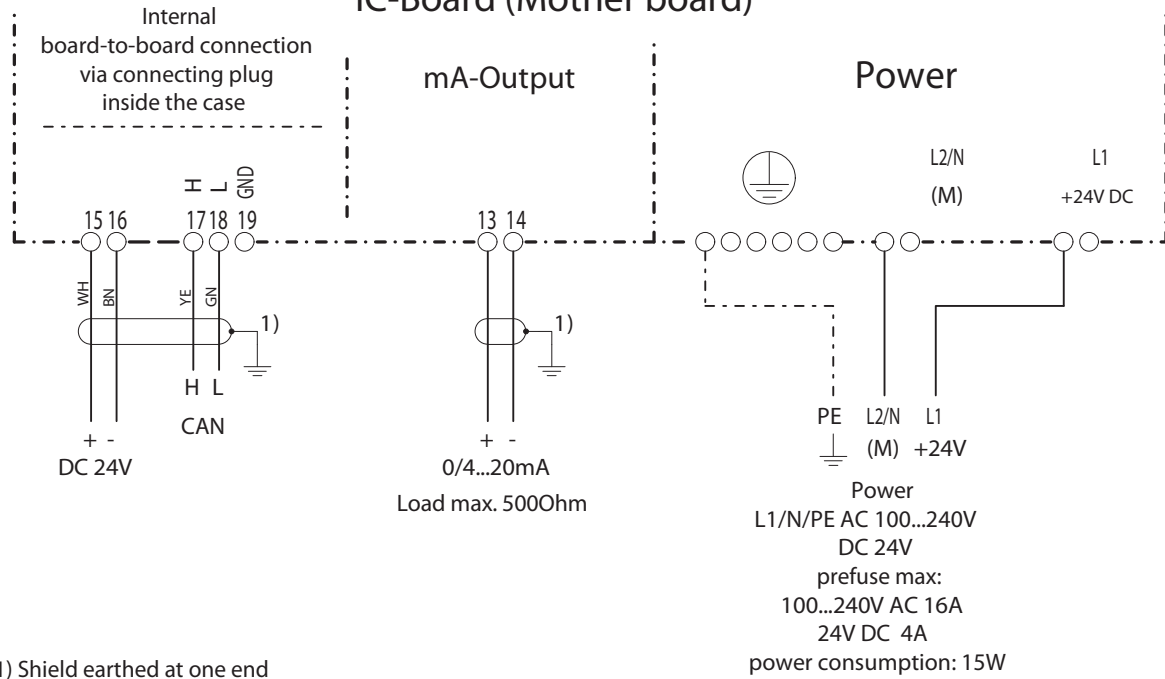

SFC - SCHEMATIC WIRING

50.590.155.030A

ISSUE 0 7-09

Connections front panel-Board (Display board)

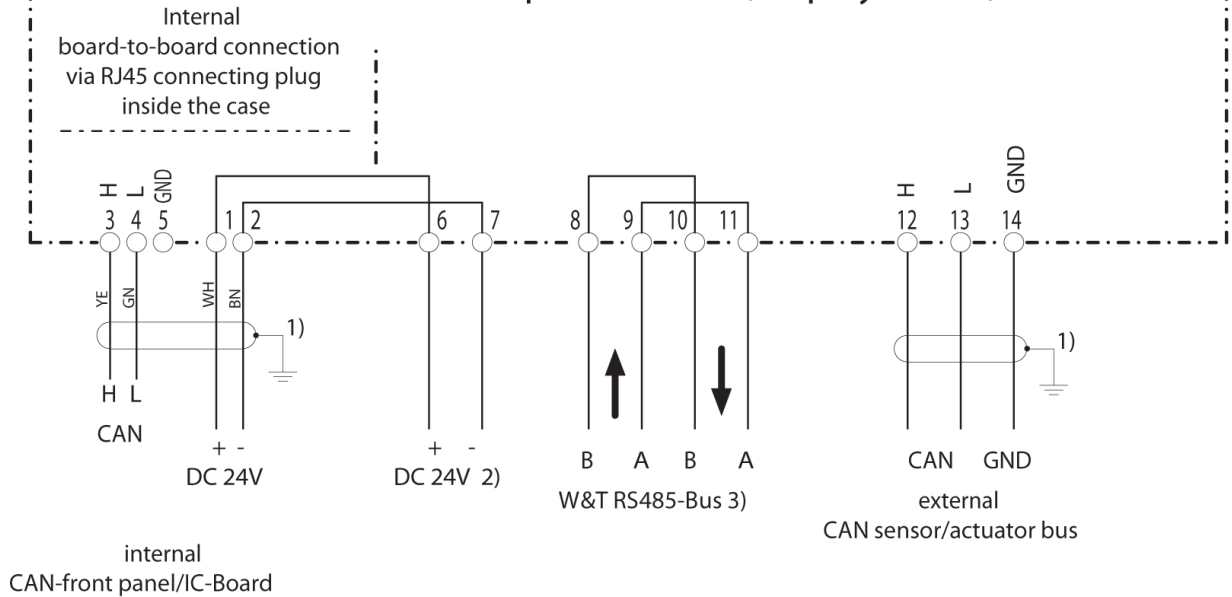

1) Shield earthed at one end

2) Only use if not using terminals 1 + 2 or preassembled plug cable

3) For shielding concept or RS485 bus design, please refer to the RS485 instructions provided with the SFC unit.

SFC- SCHEMATIC WIRING

50.590.155.030B

ISSUE 0 7-09

SFC-PC CONTROLLER

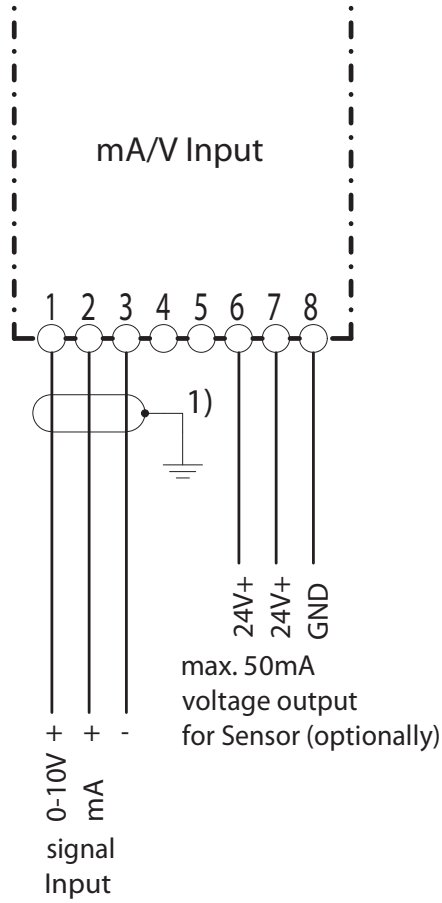

SFC - SCHEMATIC WIRING

50.590.155.030C

ISSUE 0 7-09

Relay-outputs IC-Board (Mother board)
(application 1)

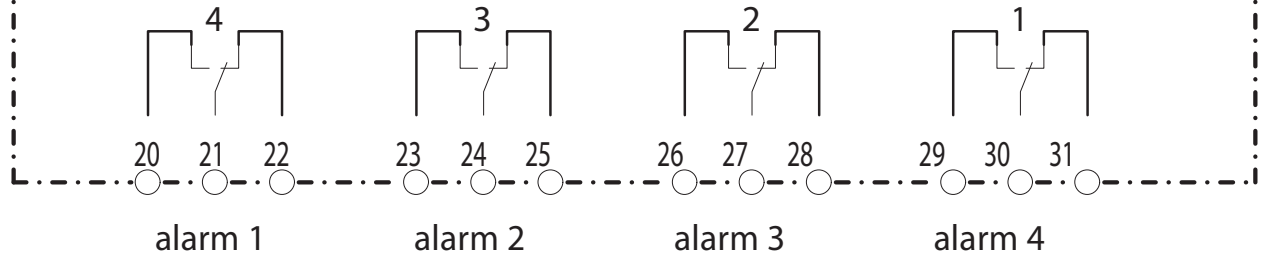

SFC- SCHEMATIC WIRING

50.590.155.030D

ISSUE 0 7-09

SFC-PC CONTROLLER

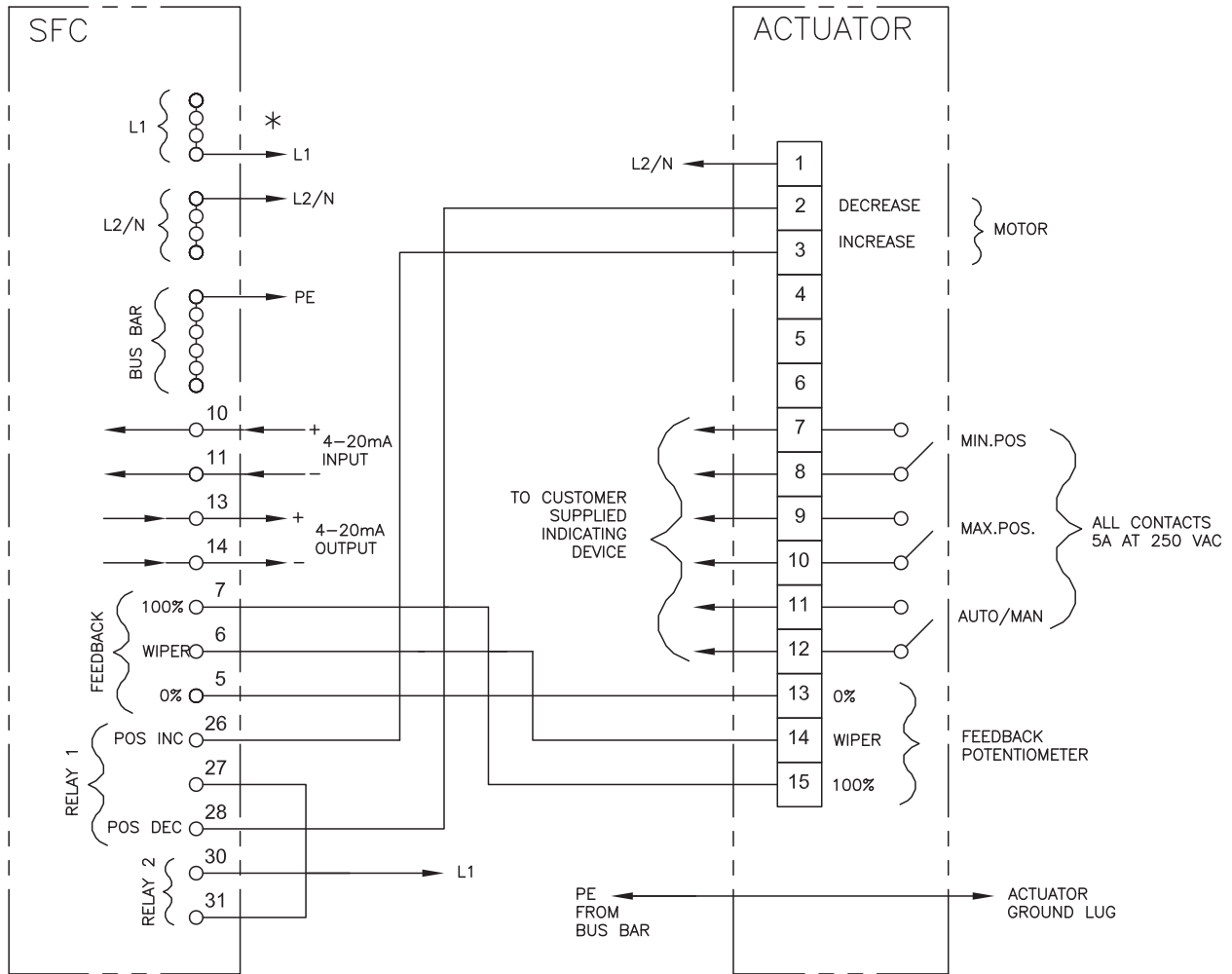

NOTE: — FIELD WIRING (NOT BY EVOQUA WATER TECHNOLOGIES) MUST CONFORM TO LOCAL ELECTRICAL CODES.
 * POWER, L1/N AC, 100...125 VAC.
 L1/L2 AC, 220...240 VAC.

CONNECTING SFC TO MOTOR CONTROLLED ACTUATORS - INSTALLATION WIRING

Used with V10K and S10K Gas Feeders; Encore® 700 Series Metering Pumps;
 and LVN-2000 Liquid Chemical Feed System
 V-Notch - W2T11479 (115VAC); UXA96285 (230VAC)
 Pump - W3T108074 (115VAC); W3T108075 (230VAC)

50.590.130.010

ISSUE 3 6-14

SFC-PC CONTROLLER

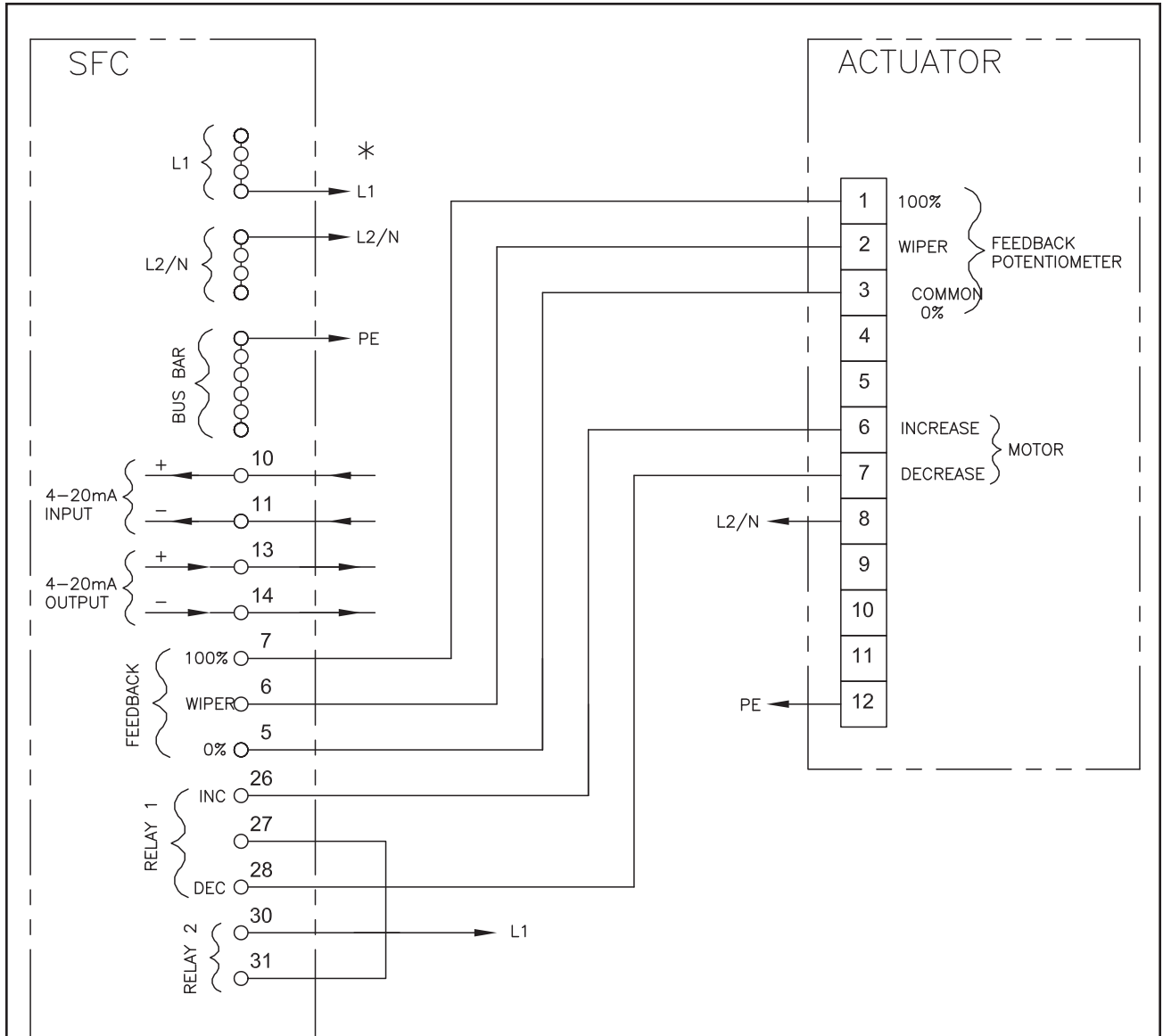

NOTES:

1. — FIELD WIRING (NOT BY EVOQUA WATER TECHNOLOGIES) MUST CONFORM TO LOCAL ELECTRICAL CODES.
2. RELEVANT INTERNAL FACTORY WIRING FOR W3T110034 ACTUATOR TERMINALS IS AS FOLLOWS:

| WIRE # | TERMINAL |
|--------|----------|
| 16 | 4 |
| 17 | 4 |
| 18 | 5 |

3. ACTUATOR KIT W3T124548 REQUIRED FOR PROPER SFC-SC RELAY OPERATION.
4. * POWER, L1/N, 100...125 VAC.
L1/L2, 220...240 VAC.

CONNECTING SFC TO MOTOR CONTROLLED ACTUATORS - INSTALLATION WIRING

Used with V-2000 Gas Feeders
V-Notch - W3T110034

50.590.130.020

ISSUE 3 6-14

SFC-PC CONTROLLER

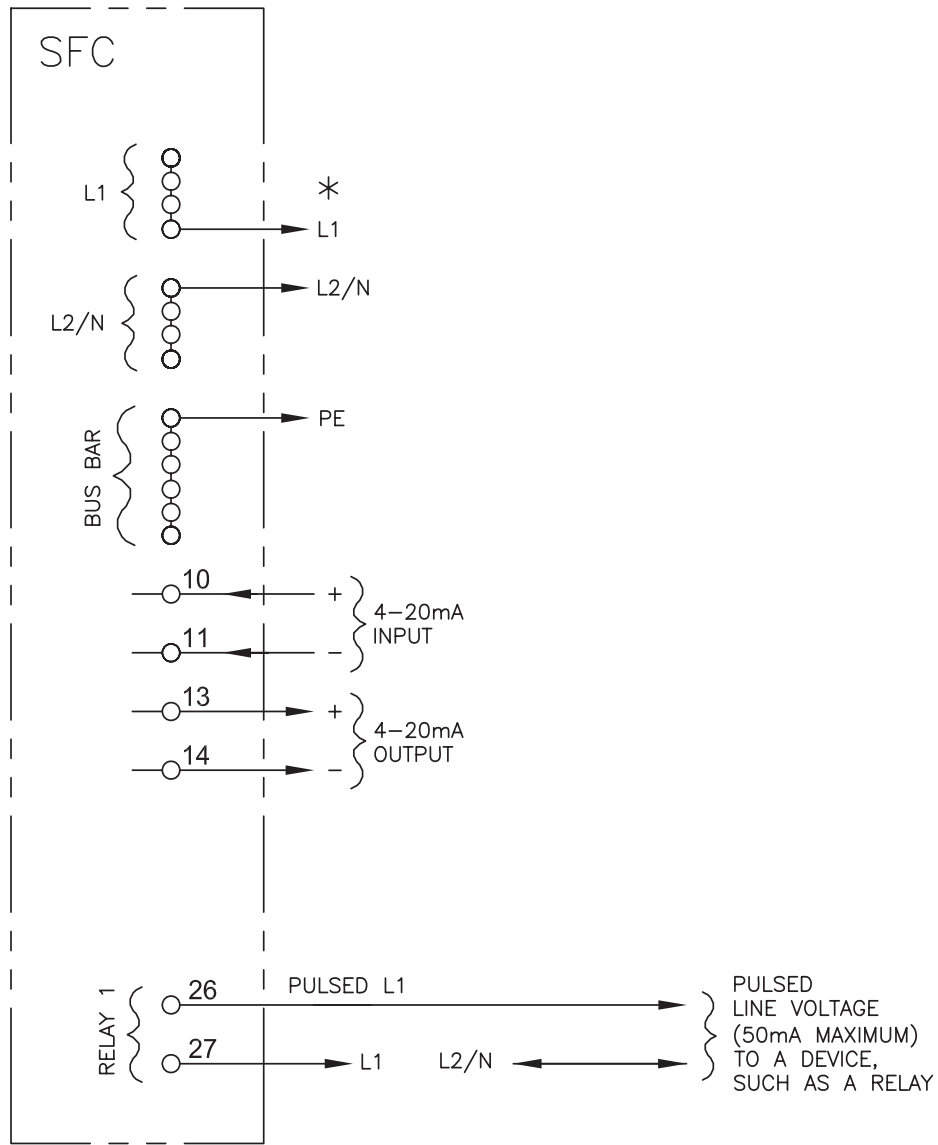

NOTE: — FIELD WIRING (NOT BY EVOQUA WATER TECHNOLOGIES) MUST CONFORM TO LOCAL ELECTRICAL CODES.
 * POWER, L1/N, 100...125 VAC.
 L1/L2, 220...240 VAC.

CONNECTING SFC TO PULSE CONTROLLED DEVICE - INSTALLATION WIRING

50.590.130.030

ISSUE 2 6-14

SFC-PC CONTROLLER

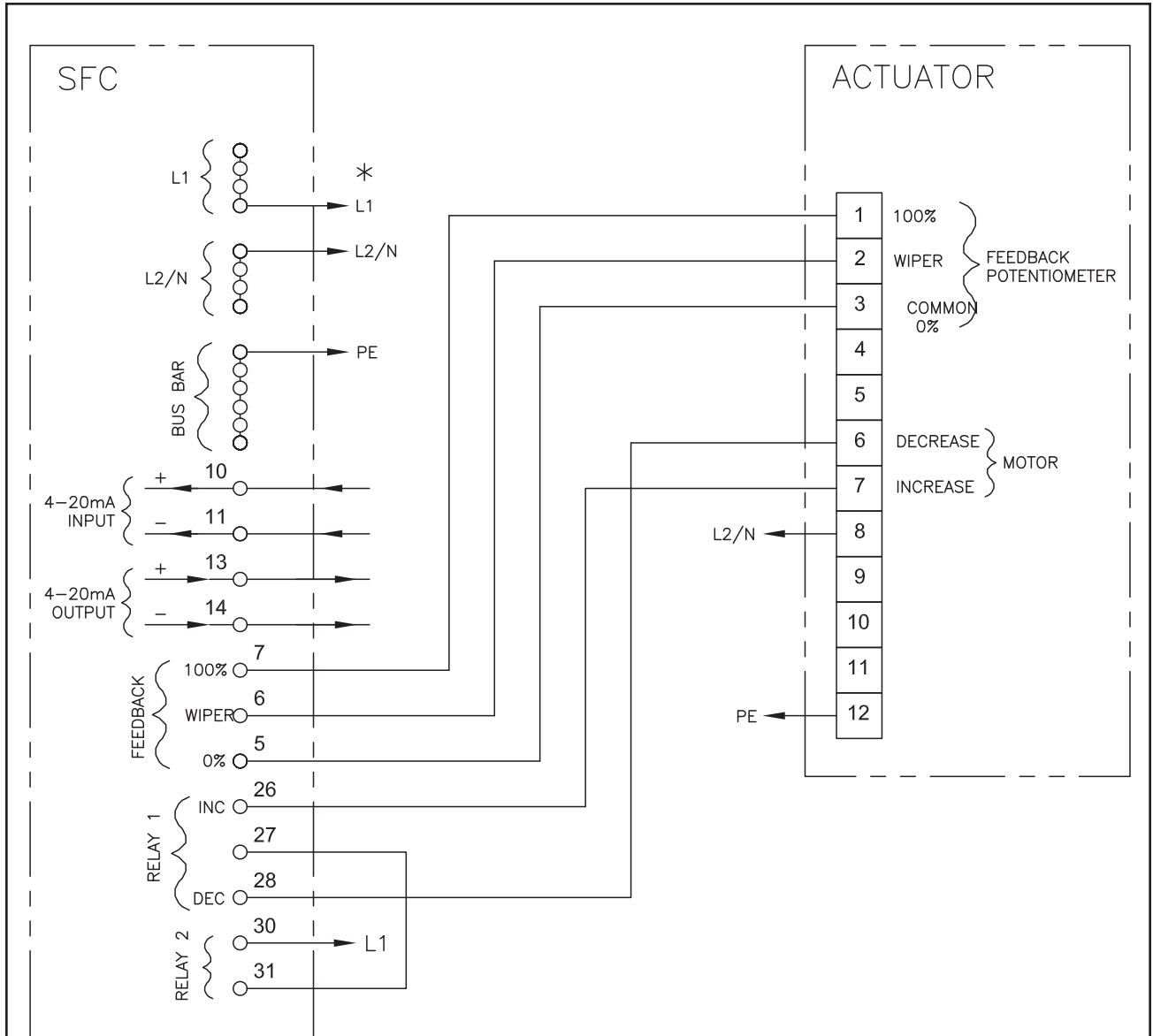

NOTES:

1. — FIELD WIRING (NOT BY EVOQUA WATER TECHNOLOGIES) MUST CONFORM TO LOCAL ELECTRICAL CODES.
2. RELEVANT INTERNAL FACTORY WIRING FOR U29202 ACTUATOR TERMINALS IS AS FOLLOWS:

| WIRE # | TERMINAL |
|--------|----------|
| 16 | 4 |
| 18 | 4 |
| 17 | 5 |

3. ACTUATOR KIT W3T124548 REQUIRED FOR PROPER SFC-SC RELAY OPERATION.
4. * POWER, L1/N, 100...125 VAC.
L1/L2, 220...240 VAC.

CONNECTING SFC TO MOTOR CONTROLLED ACTUATORS - INSTALLATION WIRING

Used with V-75, V-100 and V-500 Gas Feeders
V-Notch - U29202

50.590.130.040

ISSUE 3 6-14

SFC-PC CONTROLLER

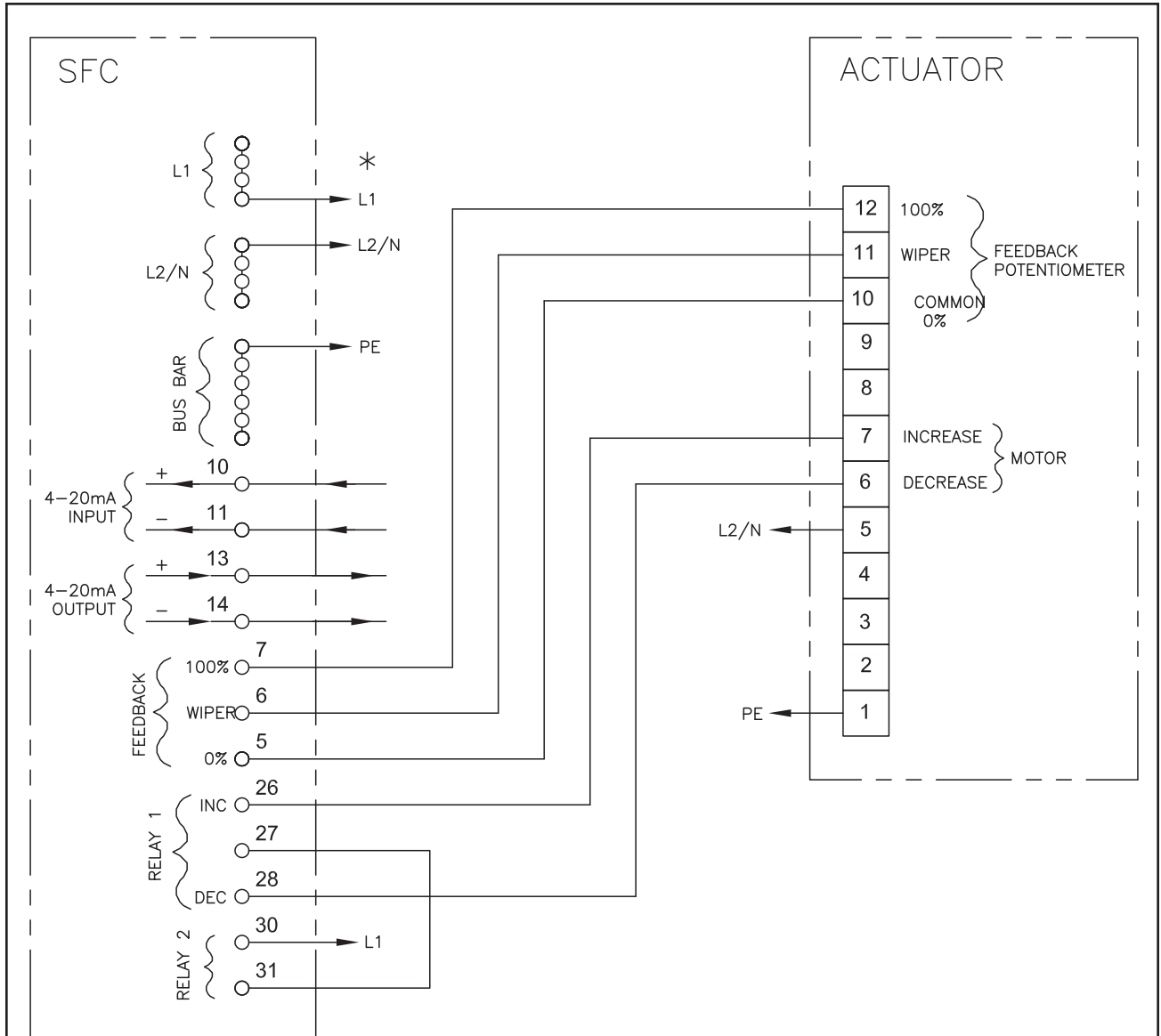

NOTES:

1. — FIELD WIRING (NOT BY EVOQUA WATER TECHNOLOGIES) MUST CONFORM TO LOCAL ELECTRICAL CODES.
2. RELEVANT INTERNAL FACTORY WIRING FOR U27960 ACTUATOR TERMINALS IS AS FOLLOWS:

| WIRE # | TERMINAL |
|--------|----------|
| 16 | 9 |
| 17 | 9 |
| 18 | 8 |

3. ACTUATOR KIT W3T124548 REQUIRED FOR PROPER SFC-SC RELAY OPERATION.
4. * POWER, L1/N, 100...125 VAC.
L1/L2, 220...240 VAC.

CONNECTING SFC TO MOTOR CONTROLLED ACTUATORS - INSTALLATION WIRING

Used with 44 Series Metering Pumps
Pump - U27960

50.590.130.050

ISSUE 3 6-14

SFC-PC CONTROLLER

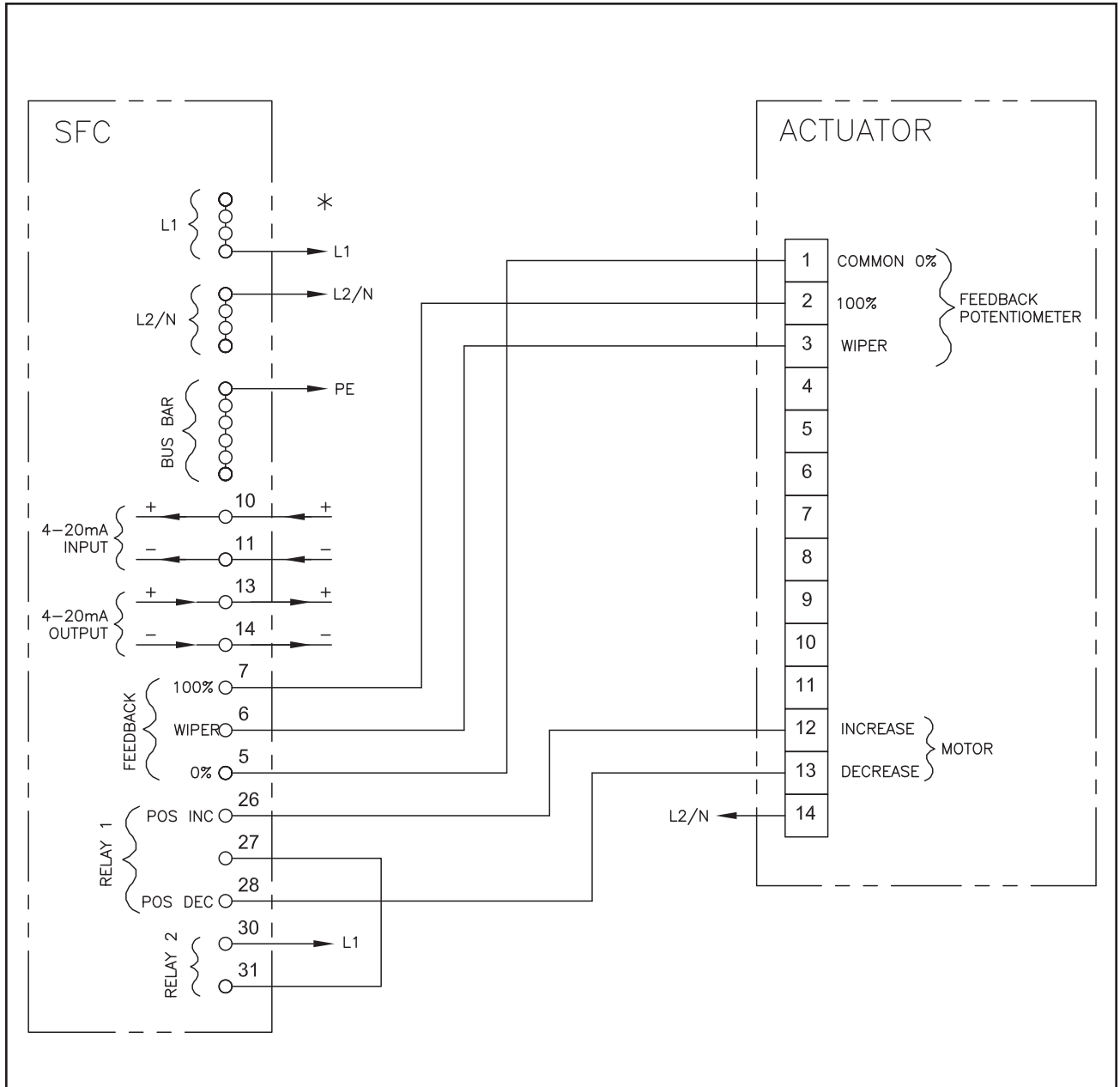

NOTE: —FIELD WIRING (NOT BY EVOQUA WATER TECHNOLOGIES) MUST CONFORM TO LOCAL ELECTRICAL CODES.

* POWER, L1/N, 100...125 VAC
L1/L2, 220...240 VAC

CONNECTING SFC TO MOTOR CONTROLLED ACTUATORS - INSTALLATION WIRING

Used with Series 43-300 HATD Pumps
Pump - U28342

50.590.130.060

ISSUE 3 6-14

SFC-PC CONTROLLER

JUNCTION BOX

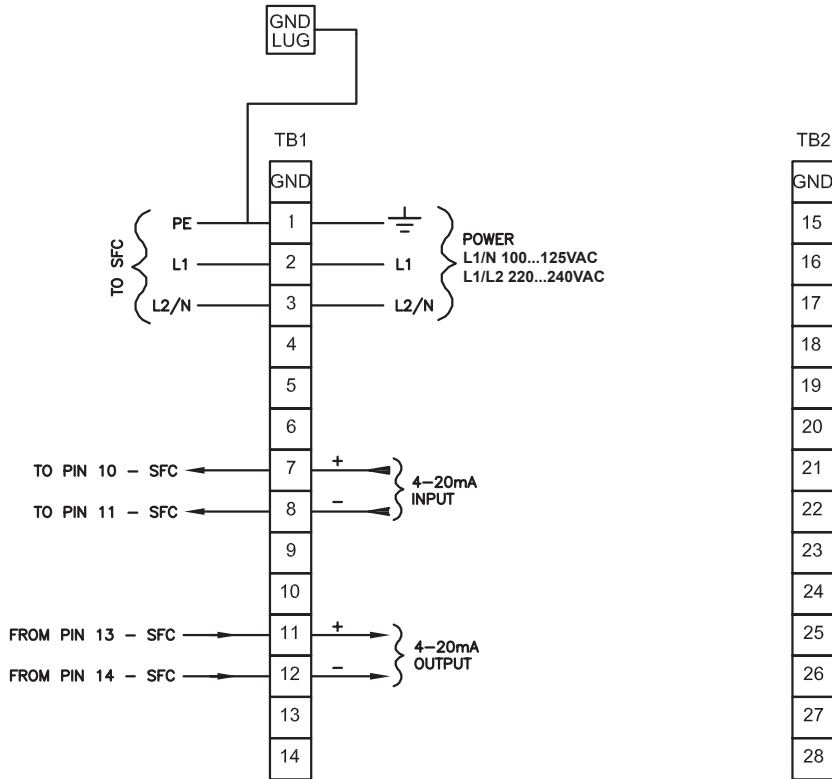

NOTE: —FIELD WIRING (NOT BY EVOQUA WATER TECHNOLOGIES) MUST CONFORM TO LOCAL ELECTRICAL CODES.

MODULE MOUNTED SFC CONTROLLER
V-2000 MODULE MOUNTED GAS FEEDER - INSTALLATION WIRING

50.590.130.070

ISSUE 2 6-14

SFC-PC CONTROLLER

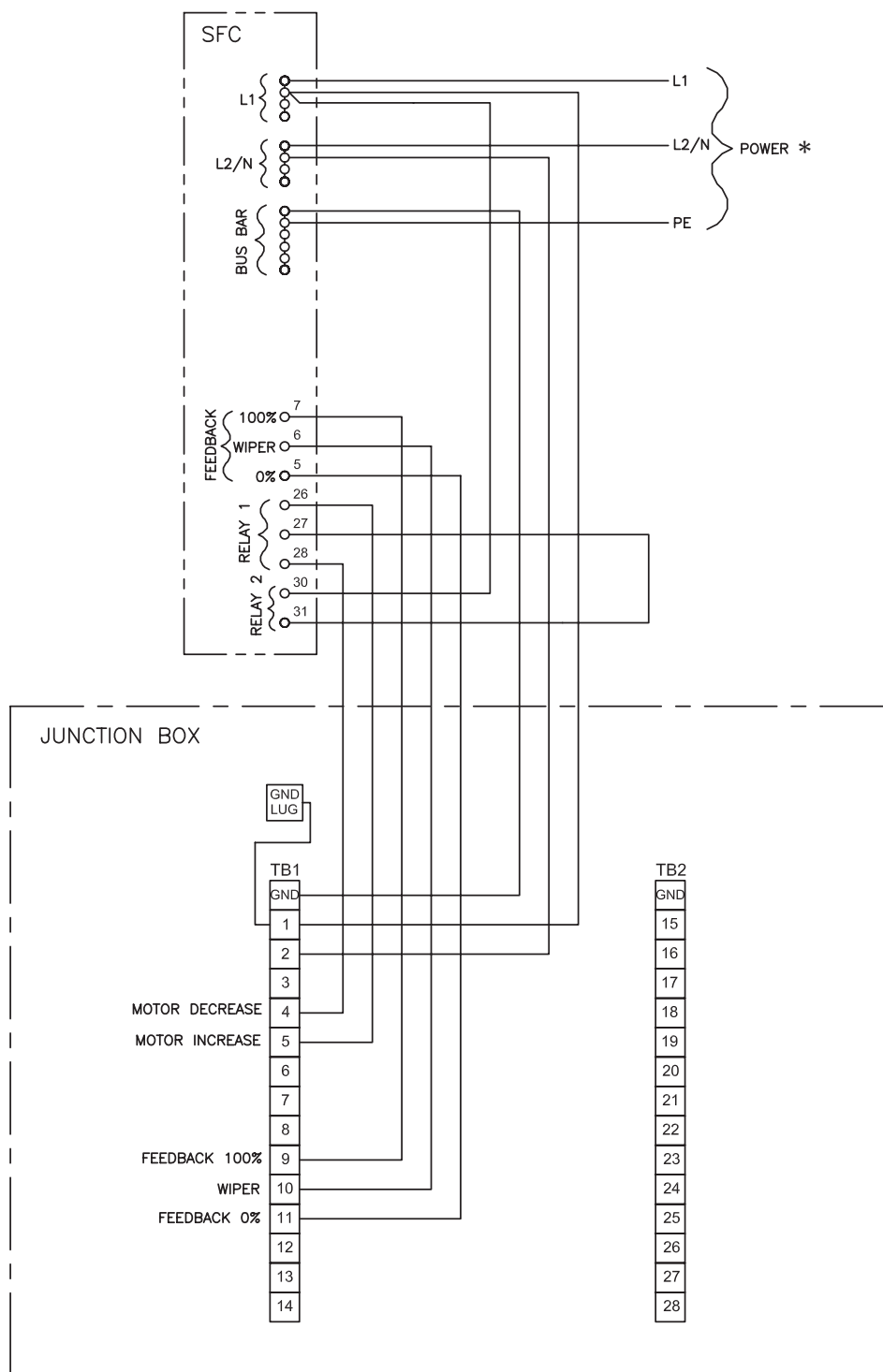

NOTE: —FIELD WIRING (NOT BY EVOQUA WATER TECHNOLOGIES) MUST CONFORM TO LOCAL ELECTRICAL CODES.
 * POWER, L1/N, 100...125 VAC.
 L1/L2, 220...240 VAC.

REMOTE MOUNTED SFC CONTROLLER
 V-2000 MODULE MOUNTED GAS FEEDER - INSTALLATION WIRING

50.590.130.080

ISSUE 2 6-14

SFC-PC CONTROLLER

JUNCTION BOX

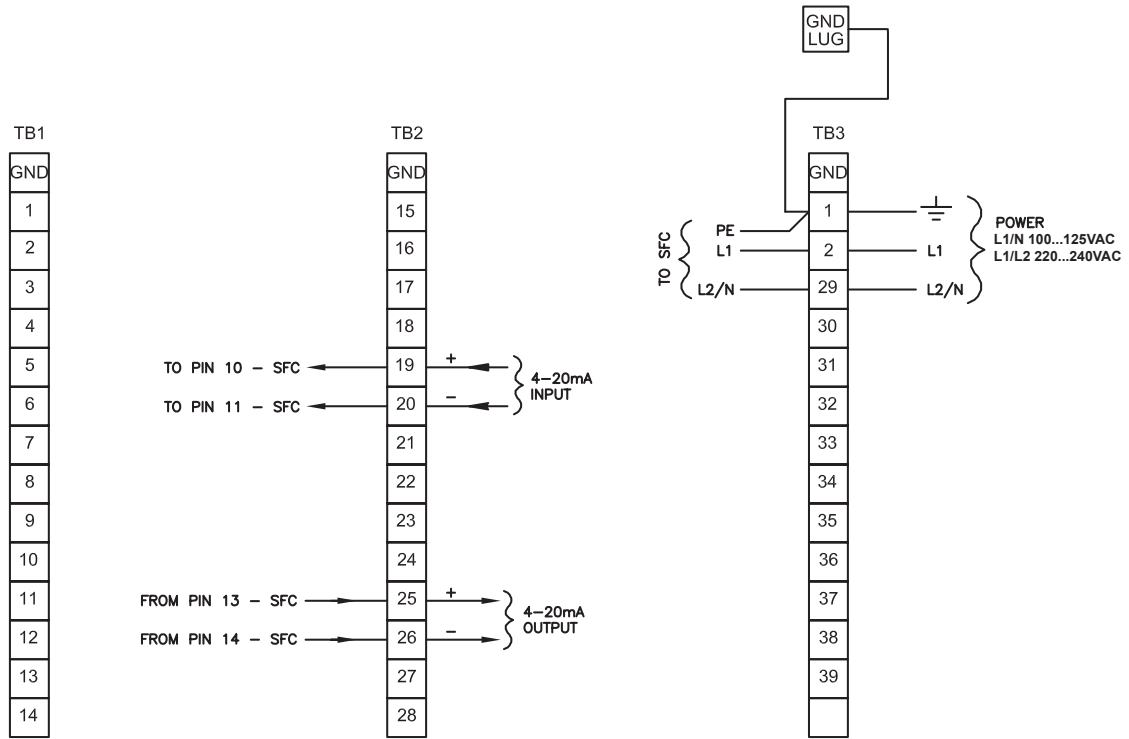

NOTE: —FIELD WIRING (NOT BY EVOQUA WATER TECHNOLOGIES) MUST CONFORM TO LOCAL ELECTRICAL CODES.

SFC CONTROLLER IN WALL MOUNTED V-2000 GAS FEEDER - INSTALLATION WIRING

50.590.130.090

ISSUE 2 6-14

SFC-PC CONTROLLER

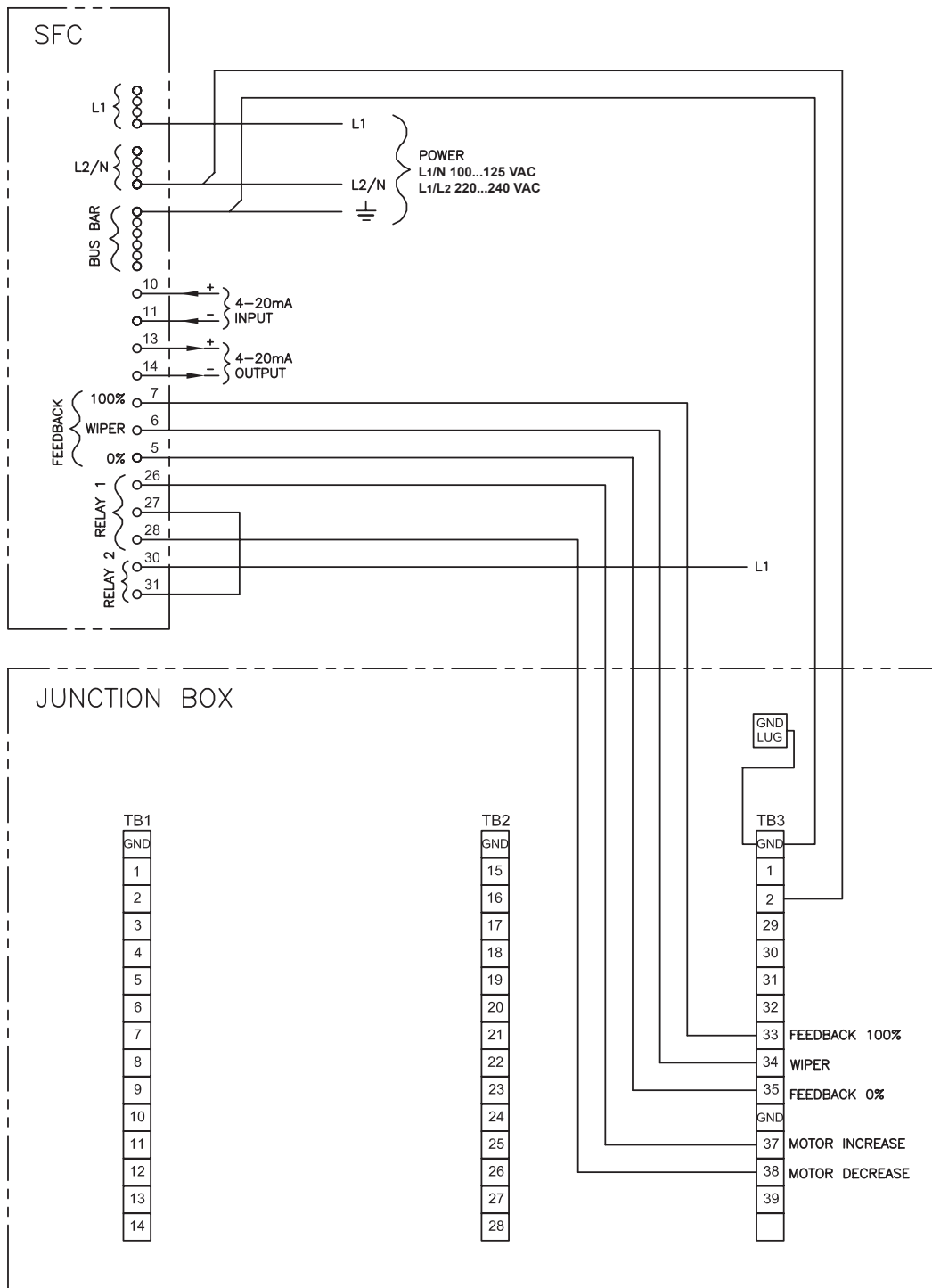

NOTE: —FIELD WIRING (NOT BY EVOQUA WATER TECHNOLOGIES) MUST CONFORM TO LOCAL ELECTRICAL CODES.

REMOTE MOUNTED SFC CONTROLLER
V-2000 WALL MOUNTED GAS FEEDER - INSTALLATION WIRING

50.590.130.100

ISSUE 2 6-14

SFC-PC CONTROLLER

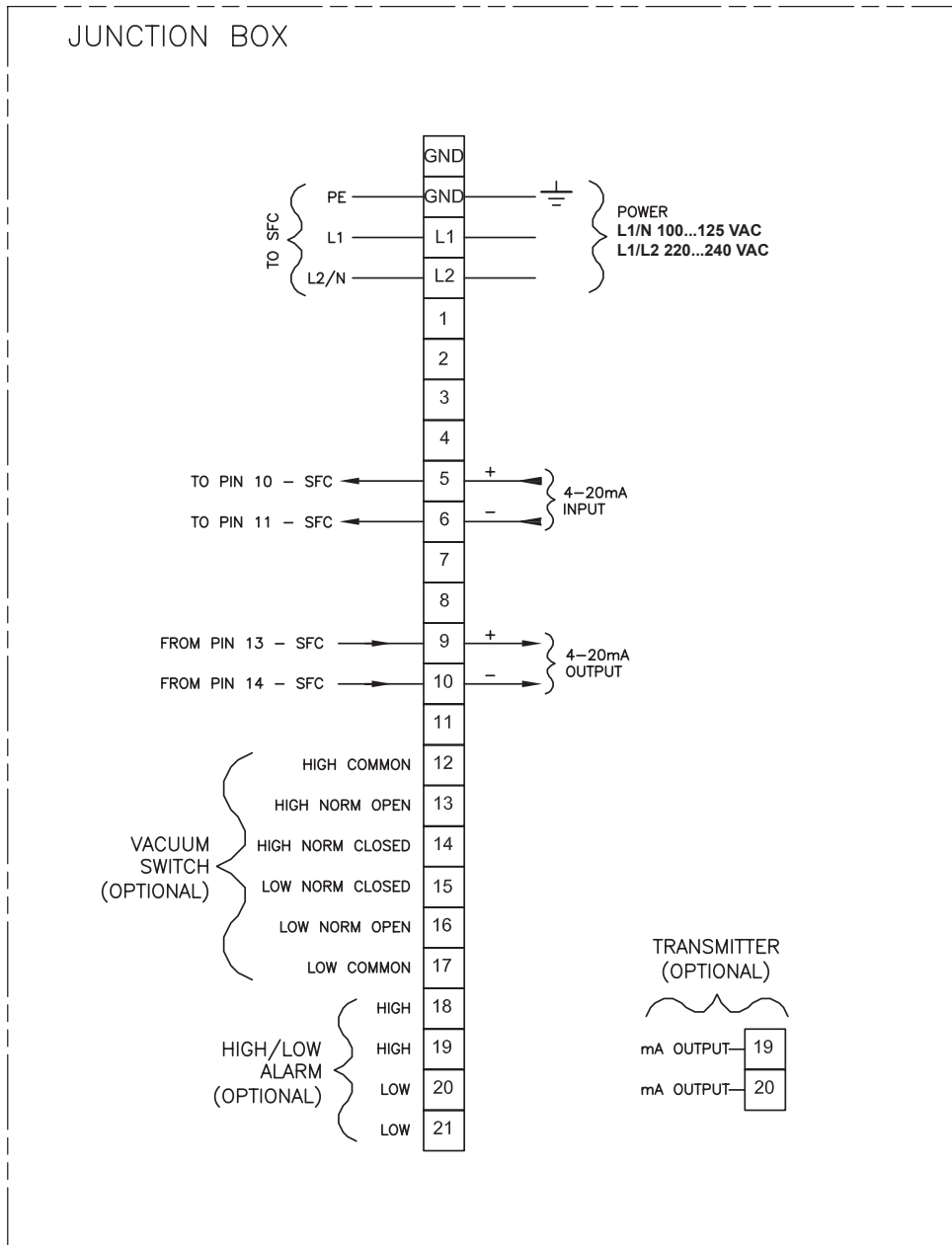

NOTE: —FIELD WIRING (NOT BY EVOQUA WATER TECHNOLOGIES) MUST CONFORM TO LOCAL ELECTRICAL CODES.

PANEL MOUNTED SFC CONTROLLER
LVN-2000 LIQUID CHEMICAL FEED SYSTEM - INSTALLATION WIRING

50.590.130.110

ISSUE 2 6-14

SFC-PC CONTROLLER

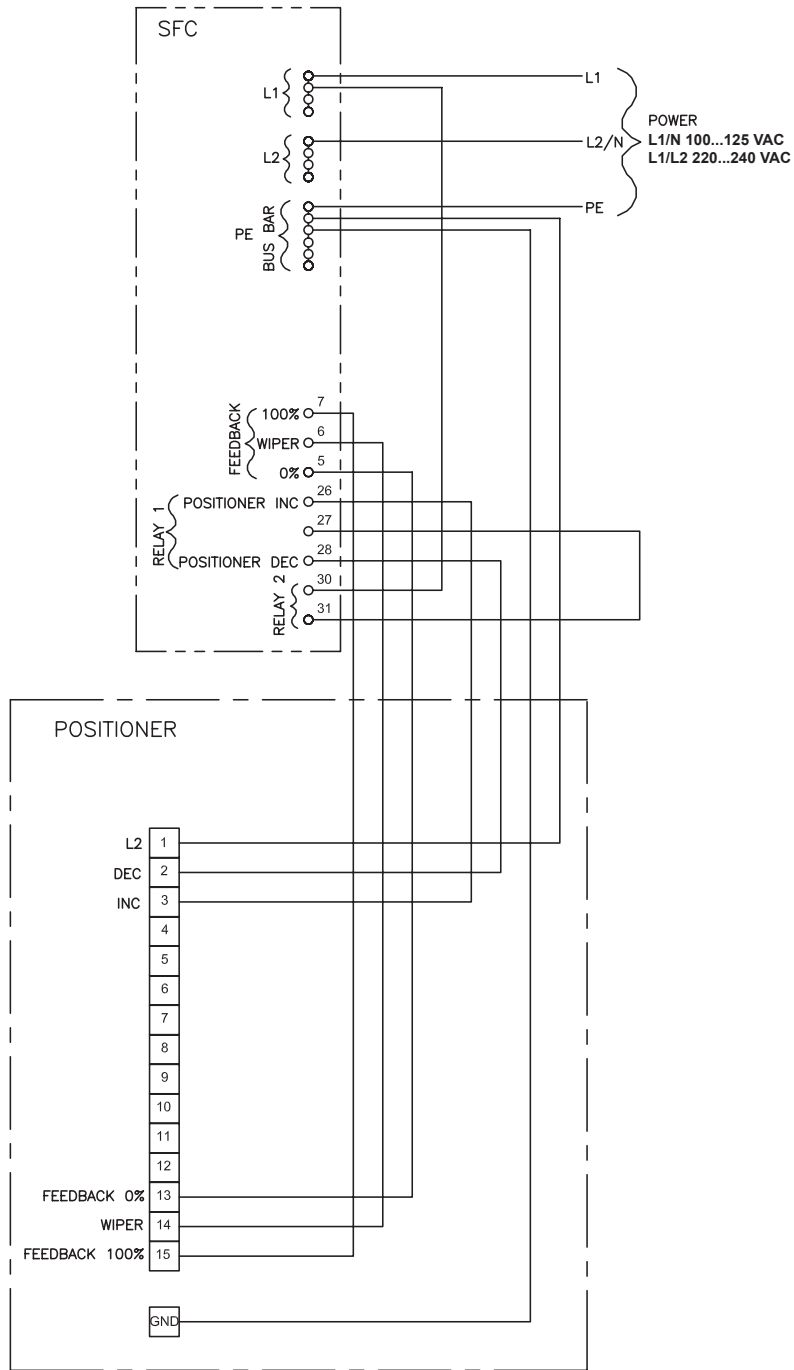

NOTE: —FIELD WIRING (NOT BY EVOQUA WATER TECHNOLOGIES) MUST CONFORM TO LOCAL ELECTRICAL CODES.

REMOTE MOUNTED SFC CONTROLLER WITHOUT JUNCTION BOX
LVN-2000 LIQUID CHEMICAL FEED SYSTEM - INSTALLATION WIRING

50.590.130.120

ISSUE 2 6-14

SFC-PC CONTROLLER

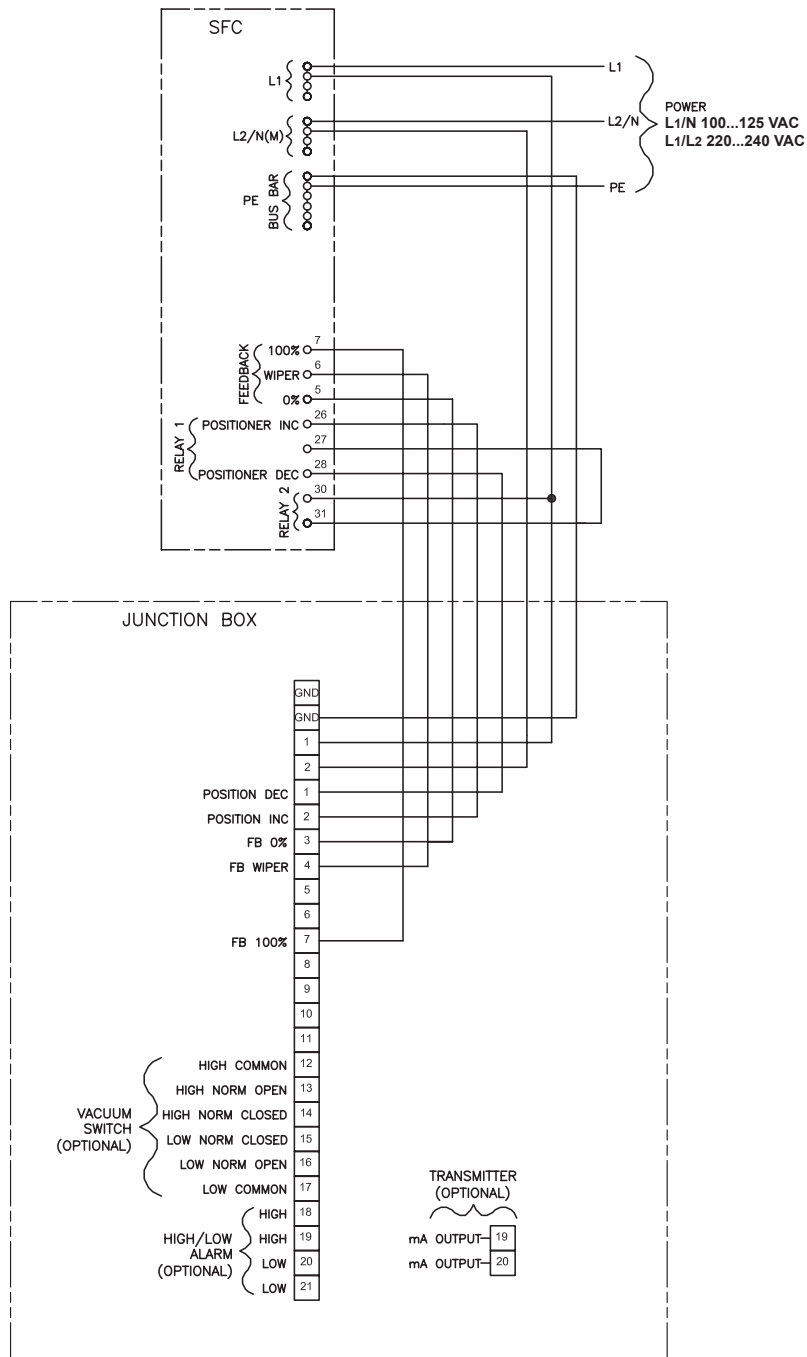

NOTE: —FIELD WIRING (NOT BY EVOQUA WATER TECHNOLOGIES) MUST CONFORM TO LOCAL ELECTRICAL CODES.

REMOTE MOUNTED SFC CONTROLLER WITH JUNCTION BOX LVN-2000 LIQUID CHEMICAL FEED SYSTEM - INSTALLATION WIRING

50.590.130.130

ISSUE 2 6-14



SFC-PC CONTROLLER

SECTION 3

SECTION 3 - SETUP AND CONTROL FUNCTIONS

List of Contents

| | PARA. NO. |
|------------------------------|-----------|
| General Information | 3.1 |
| Measurement Inputs | 3.2 |
| Outputs..... | 3.3 |
| Applications | 3.4 |
| Controller Outputs..... | 3.5 |
| Controller Parameters | 3.6 |
| Alarms | 3.7 |
| Adaption | 3.8 |
| Serial Interfaces | 3.9 |
| CAN Interface | 3.10 |
| Serial Firmware Update | 3.11 |
| Actuator Feedback..... | 3.12 |
| Digital Inputs | 3.13 |
| SD Memory Card | 3.14 |
| Unit Configuration | 3.15 |

3.1 General Information

The SFC-PC is a special control device for use on potable water, industrial process water and waste water.

Typical applications:

- Measurement and monitoring of water parameters
- Flow-controlled potable water chlorination (combi-control)
- Flow-controlled fluoroide dosing (combi-control)
- pH single feedback closed-loop control
- Chlorine single feedback closed-loop control
- Quantity-proportional dosing of disinfectants (ratio control)
- Quantity-proportional dosing of disinfectants with linearization of the actuator (with positioner)

As an option, two additional control signal inputs can be installed to log flow rate and external setpoint using combi-control or ratio control.

The intergrated graphic display shows the following:

- Measured values
- Mode
- Bar graph with limit values
- Setpoint and measuring range
- Description of customized measuring points
- etc.

The menus are easy to use, displayed in plain text and are slected using softkeys.

A 30-day trend enables you to view past measured values of up to two selectable process variables (with SD card). Without SD card, the trend from 0-24 hours is displayed.

With the SD card installed, a measured value file is saved for every month, with the available measured values and the associated time. The file is a text file and can be opened with every editor.

A mA output and a RS485 bus interface, including Wallace & Tiernan protocol, are available to connect systems. Three different process applications, which reflect the variety of on-site conditions, are integrated into the SFC to simplify commissioning.

The Cl_2^{++} value is a pH-compensated chlorine measurement (optional). This requires a pH-measurement in the same sample water as the 3-electrode cell (Not applicable to Micro/2000® and Deox/2000®).

The graphic display shows the measured data, limit values and setpoints as numeric values, diagrams or a trend line.

3.1.1 Applications

The control functions available to the SFC-PC are determined by the type of application selected.

- Single feedback closed loop control
- Combi-control
- Ratio control

3.1.2 Controller Outputs

Controller outputs for positioners, dosing pumps, pulse pumps, continuous mA output as well as a sample line dosing contact. CAN actuators are also supported.

3.1.3 Adaption Program

The adaption program automatically determines the control parameters when commissioning the single feedback closed loop control (chlorine, chlorine dioxide, ozone and potassium permanganate modules only).

3.1.4 Safety Functions

The following safety functions are integrated into the control if configured accordingly:

- Safety cut-off if dosing tank signals empty and also if the sample water supply fails
- Dosing time delay (D1)
- Alarms
- External stop for all controllers with digital input
- "Positioner closed" function in the event of a power failure (only if positioner has external power supply)
- Password protection on two levels

3.1.5 Configuration Switch-Over

The SFC gives the option of either saving internally or loading all necessary operating parameters as a configuration. A maximum of two configurations are possible. These can also be copied to or loaded from the optionally installed SD card.

3.1.6 Interfaces

The SFC supports the following links:

RS485 Interface

- CMS 3.0:
Visualization software for archiving and display of measured values on PCs with Windows operating systems
- SECO-S7:
PLC driver for data links to Evoqua PLC, Type S7-300
- OPC-Server Data Access V2.0:
Server software for Windows operating systems for data links to visualization system with OPC client capability
- ChemWeb-Server:
Measured value archiving and display, remote diagnosis, remote access with standard browser with Internet and e-mail capability
- Process control systems of different manufacturers
(refer to the manual "RS485 Bus Interface for MFC" WT.050.580.002.UA.IM for description, specification and protocol)

CAN Interface

- The SFC has an integrated CAN interface. This is used for data exchange between CAN-capable actuators and measuring and control devices. (See section 3.10, CAN Interface, for description and bus system.)

3.2 Measurement Inputs

3.2.1 mA/V Input Module

The mA/V input module is used for connecting sensors or external measurements with mA or voltage output signal. 0/4 – 20 mA signal or 0 – 10 V input voltage are possible.

Various controller functions are available depending on the application selected. If the mA/V module is used with the "Process Control" option (PC), combi-control and ratio control are also available.

As measured value display, the unit and display format can be freely selected in the menu.

3.2.2 mA Inputs of the IC Boards

The IC board integrates two mA inputs (mA 1 and mA 2) for recording process parameters.

| | |
|------------|--|
| mA input 1 | Used for recording the flow rate signal as 0–20 mA or 4–20 mA signal. |
| mA input 2 | Used for recording an external setpoint value or dosing factor as 0–20 mA signal. Both input signals can be freely scaled in the menu (see Inputs/Outputs menu). |

3.3 Outputs

3.3.1 mA Output

The mA output of the SFC is electronically isolated and can be parameterized to 0–5 mA, 0–10 mA, 0–20 mA or 4–20 mA in the menu. Any measured value, actuator output (Y_{out}) or temperature can be assigned to the mA outputs.

3.3.2 Relay Outputs

The SFC has a maximum of four relays, each with a two-way switch. These switches are assigned various switching tasks depending on the selected application (see section 3.4 - Applications). The corresponding diagrams for the three applications are in section 5 - SFC Wiring Diagrams. In order to switch larger inductive load, we recommend installing an additional contact such as a contactor or load relay, in order to guarantee the contacts have a longer service life.

Protection of the relay contacts of alarm and control outputs is provided at the factory using RC circuits. These provide radio interference suppression for inductive loads such as pumps, motors, etc.

Connection of small loads

When connecting small loads to the mains voltage, e.g. contactors or positioners with low power consumption (e.g. V10K), the closed-circuit current via the RC circuits can suffice to activate the loads (humming of the positioner, contactor is not deactivated, etc.). In this case, the plug-in jumpers of the relevant contacts should be removed to deactivate the RC circuits.

| | | | |
|----|-------|----|---------|
| K1 | J6/J7 | K3 | J10/J11 |
| K2 | J8/J9 | K4 | J12/J13 |

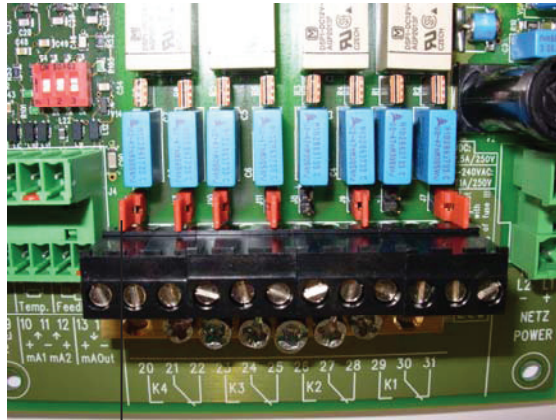

Plug-in jumpers

Figure 3.1 - Connection diagram

3.4 Applications

The configuration of the system is determined by:

- The Version of the SFC
- The required measurement and control parameters
- The installed components
- The selection of the suitable application
- The type of sensor module installed

The SFC provides the option to customize the system to the various on-site systems using five integrated applications.

- Factory setting of version 1 - analyzer = application 1
- Factory setting of version 1 - analyzer/controller = application 2
- Factory setting of version 2 = application 3

The connections are determined by selecting the applications 1, 2, or 3. Factory settings are always set for the respective application. However, these can be customized to the respective system.

NOTE: The defined application 1, 2, or 3 must be entered the first time the device is switched on (see section 2.3.10, “Switching the device on”). It is then not possible to change this for the defined configuration, otherwise the incorrect controller outputs are activated.

The three applications 1, 2, and 3 are shown below.

3.4.1 Application 1 - Process Measurement

With application 1, the SFC operates exclusively as a measuring device. A maximum of four freely configurable alarm relays are available. The type of measurement is determined by the type of the sensor measuring module. Controller outputs are not supported in this application.

Figure 3.16 gives an overview of the available inputs and outputs of the SFC.

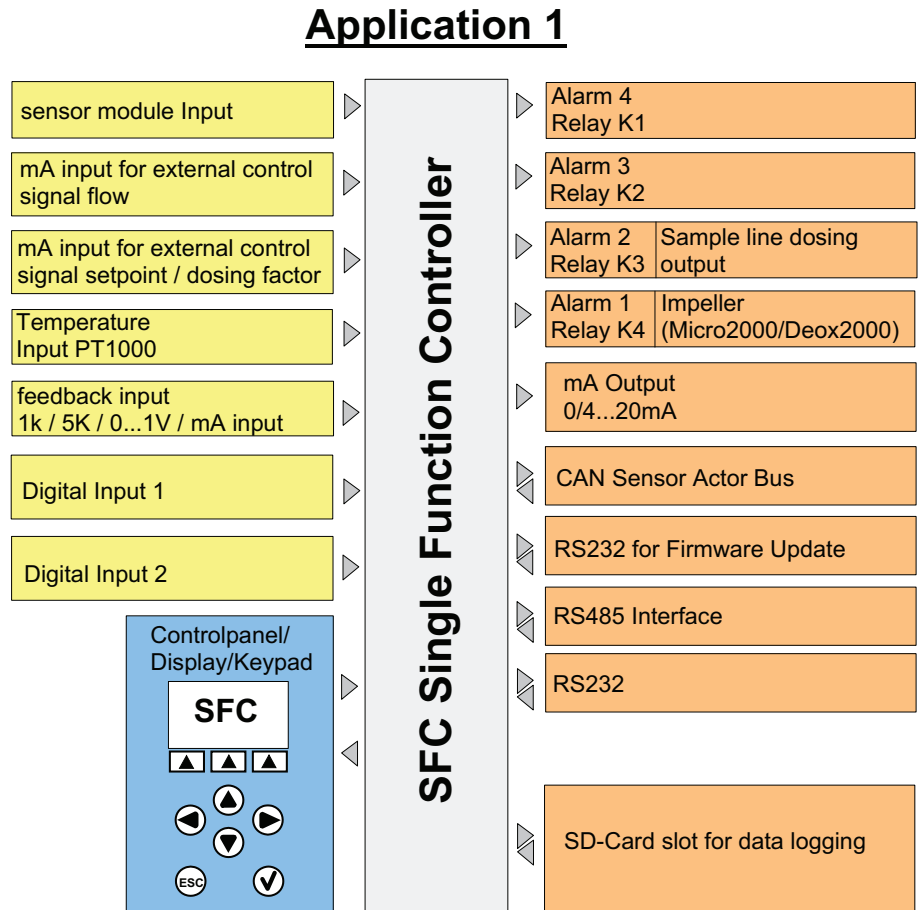

Figure 3.2 - Application 1

Figure 3.3 shows a sample implementation of application 1 as individual process measurement. The measured value can be forwarded via mA signal or CAN bus to a higher-level controller.

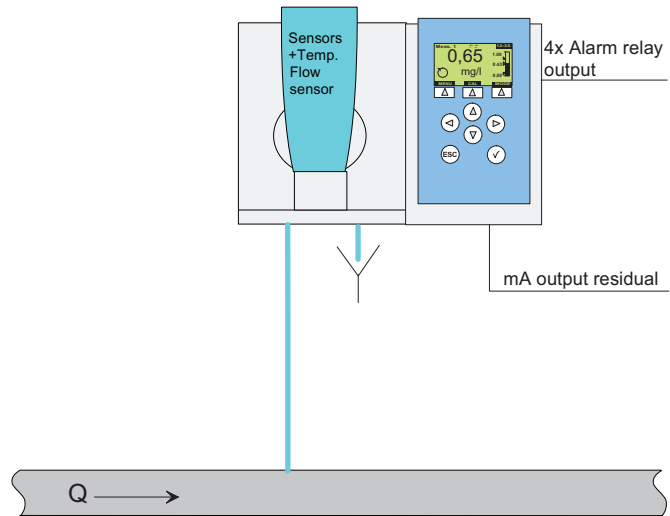

Figure 3.3 - Process measurement

3.4.2 Application 2

In application 2, the SFC works as a measuring device and as a control device. Various controller modes can be selected depending on the installed sensor measuring module:

- Sensor measuring module without "Process Control" option (PC)
 - ◆ Single feedback closed loop control
- Sensor measuring module with "Process Control" option (PC)
 - ◆ Single feedback closed loop control
 - ◆ Combi-control
 - ◆ Ratio control

Application 2

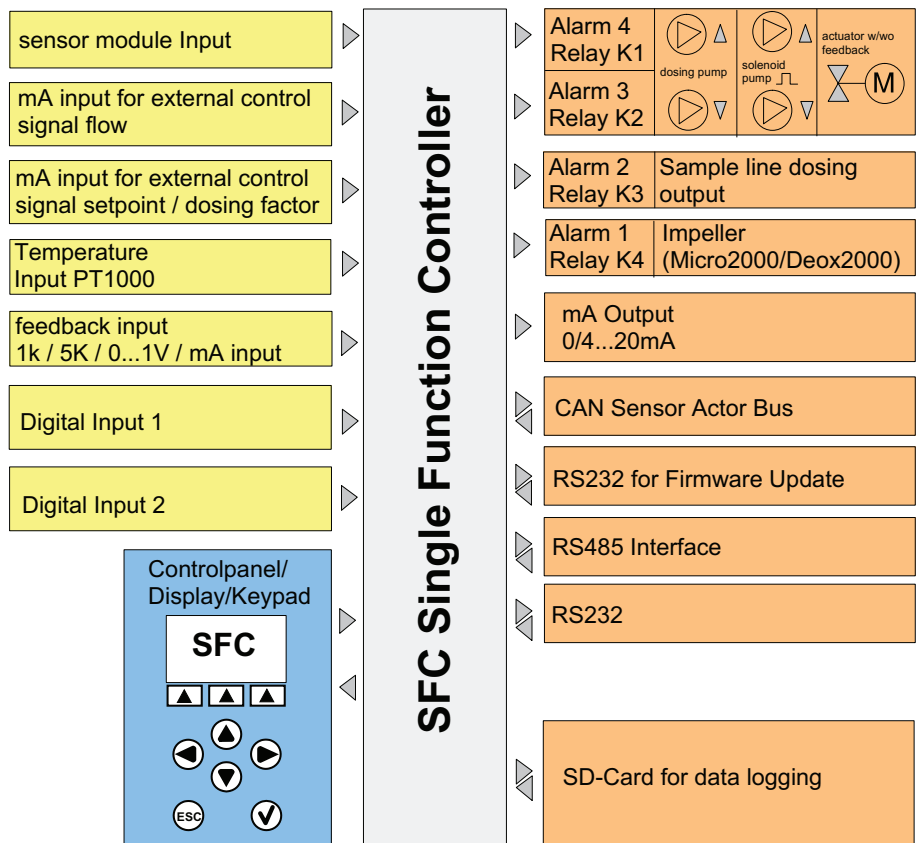

Figure 3.4 - Application 2

Controller functions in Application 2

The following integrated control modes are available for selection:

- Ratio control (with Process Control option)
- Single feedback closed loop control
- Combi-control (with Process Control option)
- Ratio control with linearization of the positioner output, with actuators with feedback output, (max. 11 calibration points) (with Process Control option).

Online measurements can be transmitted direct from the SFC by means of a sensor measuring module and from external measuring systems via mA input signal. External control signals, such as flow rate and external setpoint, are recorded by two integrated mA inputs. The SFC system can record a main measurement and two external control signals. In addition, measuring inputs for temperature, actuator feedback and two digital inputs are available.

3.4.2.1 Ratio Control and Flow Proportional

This operating mode controls the quantity-proportional dosing of disinfectants. The ratio control with process measurement is only supported with sensor measuring modules with the Process Control option.

A typical application is simple flow-controlled potable water chlorination, as shown in the following figure.

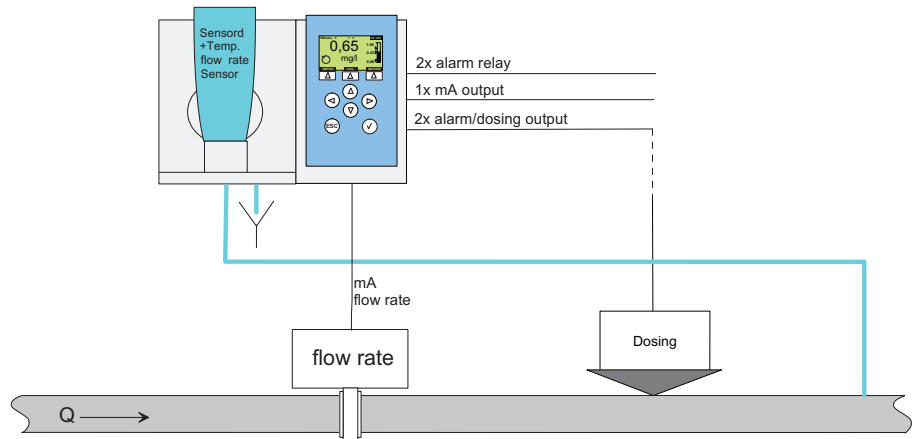

Figure 3.5 - Process measurement with ration control

Required module configuration:

- MOD1 -To record the measured value

Input signals:

- Module 1 measured value recording
- Flow rate measurement (0/4 – 20mA) scalable
- Second control variable is possible via sensor measuring module
- Internal or external dosing factor (0/4 – 20 mA)

The following controller outputs are possible:

- Dosing pump
- Pulse pump
- Positioner with feedback 1kOhm/5kOhm/0 –1 V/mA signal
- mA analog output

Ratio Control Theory of Operation

The flow rate is recorded and the dosing rate adjusted proportionally to the flow rate using the flow rate sensor with linear mA/V output signal.

For the flow signal settings, see menu “Input/Output” – “Flow Wq”.

NOTE: If the measuring range end value of the flow meter is not identical with the actual maximum flow rate, a factor for adjusting the flow rate signal should be input in the menu "Inputs/Outputs" - "Flow Wq".

For example: Measuring range flow meter = 5000 l/h / max. flow rate = 2500 l/h => factor = 5000: 2500 = 2.0

The ratio between control variables and dosing output is determined by the internal dosing factor (control "Dos.Fact.Source" = internal), or it can also be set by an external mA/V input signal (Dos.Fact.Source = external).

You can switch between internal and external dosing factor (DF) via the digital input (“Dos.Fact.Source” = “external with DI3” or “internal with DI3”).

It is possible that a second control variable “Measured Value X” (measured value from module 1) will proportionally or reverse proportionally influence the ratio control (“X-direction” = direct / inverse variable).

The second control variable X is activate if the parameter “Control Variable X” “Measured Value X” (second control variable deactivated by “Off” setting (factory setting)).

SFC-PC CONTROLLER

The amplification factor for this parameter is defined by the X-factor input parameter.

The controller output is calculated in this operating mode as follows:

$$Y_{out} = Wq \times DF \times (X\text{-measured value} \times X\text{-factor}) \times Y_{out\text{-factor}}$$

| | |
|-------------------------|--|
| <i>Wq</i> | <i>Control variable 1 flow in %</i> |
| <i>DF</i> | <i>Set dosing factor in %</i> |
| <i>X-measured value</i> | <i>Control variable 2 measured value sensor measuring module 1 in %</i> |
| <i>Yout</i> | <i>Amplification factor for X measured value</i> |
| <i>Yout</i> | <i>Determined controller output value %</i> |
| <i>Yout factor</i> | <i>This factor gives the option of increasing the dosing output by a dosing factor DF of 100% when the setpoint value is not reached. Increase the dosing output. Setting range: 1.0– 4.0 Factory setting: 1</i> |

NOTE: If this factor is increased, there is a danger that the setpoint value will also not be reached with a higher flow rate value, because the Yout value takes the value 100 % prematurely.

Single Feedback Closed-Loop Control with Process Measurement

This operating mode controls the desired measured variable according to the provided setpoint. Single feedback closed loop control is supported with all sensor measuring modules (with and without the Process Control option).

The following figure shows a typical application of a chlorine single feedback closed loop control for tanks which are circulated in cycles.

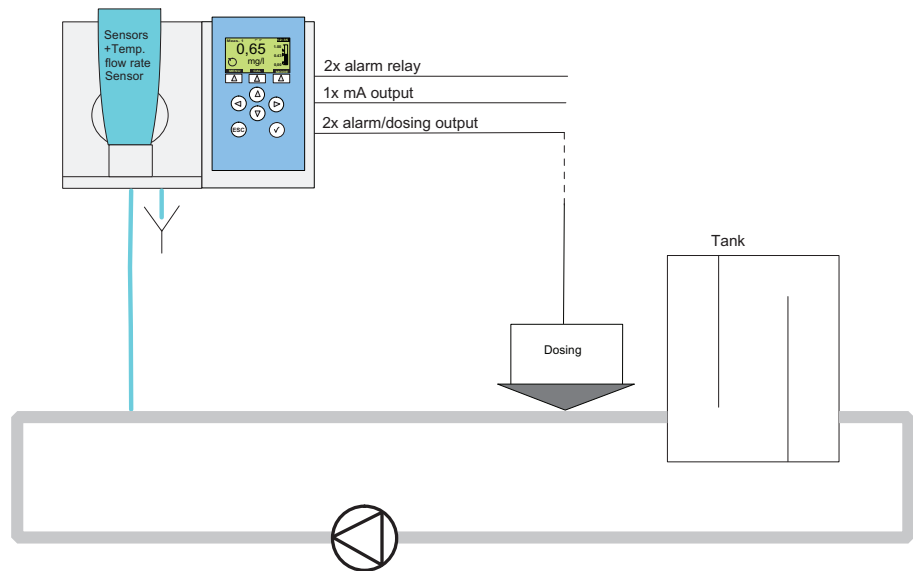

Figure 3.6 - Process measurement with single feedback closed loop control

NOTE: This control operating mode is only available when application 2 is selected.

Required module configuration:

- Sensor measuring module for measured value recording

Input signals:

- Measured value recording module
- Internal or external setpoint module

The following controller outputs are possible:

- Dosing pumps
- Solenoid pump
- Positioner with/without feedback (1kOhm/5kOhm/0-1 V/mA)
- Continuous
- CAN actuator

Single Feedback Closed-Loop Control Theory of Operation

A PI controller is used to control the measured variables of the sensor measuring module continuously and without control deviation from the desired setpoint. It continuously determines the required dosing output.

The setpoint can be set within the measuring range (at "Setpoint Source" = internal).

SFC-PC CONTROLLER

Xp and Tn are control parameters to be set. They can also be automatically determined via the integrated adaption during a chlorine control.

An external setpoint from 0–100 % can be provided via the mA/V input signal (“Setpoint Source” = external) You can switch between internal and external setpoint via the digital input (“Setpoint Source” = “external with DI3” or “internal with DI3”).

The control direction can be selected with the parameter “Control Direction” = direct or inverse (e.g. direct = chlorination, inverse = dechlorination).

The controller output is calculated in this operating mode as follows:

$$Y_{out} = Y_{pi} = e_k \times K_p \times (1 + t/t_n)$$

| | |
|------------------------|--|
| <i>t</i> | <i>Controller cycle time</i> |
| <i>t_n</i> | <i>Integral action time</i> |
| <i>K_p</i> | <i>Control amplification 100 / X_p</i> |
| <i>e_k</i> | <i>Setpoint-actual value control deviation</i> |
| <i>Y_{pi}</i> | <i>PI controller output variable</i> |
| <i>Y_{out}</i> | <i>Determined controller output value %</i> |

Compound Loop with Process Control

The compound loop control is a combination of the ratio control with additional single feedback closed-loop control to correct control deviations. The combi-control is only supported with sensor measuring modules with the Process Control option.

The following figure shows a typical chlorine combi-control as implemented in the treatment of potable water.

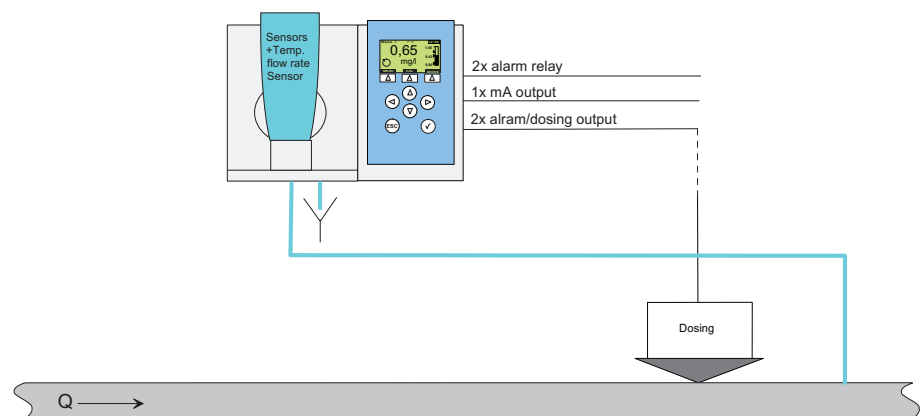

Figure 3.7 - Process measurement with combi-control

Required module configuration:

- Sensor measuring module for measured value recording

Input signals:

- Flow rate measurement (0/4–20mA) scalable
- Measured value recording module
- Internal or external setpoint module

Output parameter:

- Dosing pumps
- Solenoid pump
- Positioner with/without feedback (1kOhm/5kOhm)
- Continuous
- CAN actuator

Compound Loop Control Theory of Operation

The combi-controller outputs a dosing rate proportional to the flow rate, which does not have a fixed dosing factor proportional to the flow rate as in the ratio control, but varies depending on demand.

To detect control deviations, the sensor measuring module records the control variable and a setpoint is specified, which are compared with the integrated single feedback closed-loop control.

The internal setpoint can be set within the measuring range. “Setpoint Source” must be set to “internal”. An external setpoint from 0–100 % can be provided via the mA/V input signal. “Setpoint Source” must be set to “external”. You can switch between internal and external setpoint via the digital input. The “Setpoint Source” must be set to “external with DI3” or “internal with DI3”.

The X_p and T_n control parameters of this higher-level single feedback closed-loop control are automatically determined by the integrated fuzzy logic T_{const} and T_{var} process times to be entered at 100 % flow rate. Because the T_{var} process time changes, T_{var} , X_p and T_n are continuously updated by the integrated fuzzy logic.

The SFC operates internally with a dosing factor table for 0 – 105% flow. In 5% intervals, the device determines the required dosing factors automatically during operation based on the corresponding flow rate. The single feedback closed-loop control corrections are transferred into the dosing factor table during this process. Non-linearities in the control loop are learned this way. This quickly activates the setpoint if flow rate changes occur.

The dosing factor table can be checked in the "Diagnosis" menu. It is possible to delete the dosing factor table and to initialize it with a particular dosing factor (factory setting: 50%), for example, in order to prevent too high dosing factors during commissioning. To do this, the required dosing factor must be entered in the menu "System" - "Reset" - "Dosing Factors".

The control operating mode can be switched between ratio control and single feedback closed-loop control via digital input.

The control direction can be selected with the parameter "Control Direction" = direct or inverse (e.g. direct = chlorination, inverse = dechlorination)

Behavior in Operation

Operation after a flow rate change:

The single feedback closed-loop control remains switched off (Ypi stop function) during the disturbance variables (flow rate change, positioner running time, dead time from line lengths). This maintains a stable control, which means the control operates with the dosing factor from the dosing factor table applicable for the new flow rate. The time the single feedback closed-loop control is switched off is determined by the fuzzy module and is therefore variable ("PI" display in seconds).

A larger change in the setpoint deletes all learning meters, in order to reinitialise the dosing rate curve when the setpoint is reached. However, the learned dosing factors remain initially unchanged. Inactivated flow rate values are automatically preassigned a dosing factor. The single feedback closed-loop control is always active.

Control deviations that occur are quickly offset by the PI single feedback closed-loop control during continuous flow.

A positive jump in the flow rate causes a brief drop below the setpoint due to the running time of the positioner and the dosing delay. Therefore, the PI controller freezes for a brief period ("PI" display in seconds).

A negative jump in the flow rate causes the setpoint to be briefly exceeded due to the running time of the positioner and the dosing delay. Therefore, the PI controller freezes for a brief period ("PI" display in seconds).

The PI controller is not deactivated if the flow rate is continuously rising or falling if the dosing rate can quickly adjust to these changes. This is true of fast positioner running times and loops without dosing delay.

Special Functions

- The control direction can be switched.
- Automatic determination of the control parameter using the integrated fuzzy module. The fuzzy module determines the control parameter from the embedded Tconst and Tvar process times.
- The setpoint can be switched between internal and external
- Ypi stop function during a change in control variable
- Control variable Wq available optionally as proportional or indirect proportional as well as factor adjustment
- Smooth switch from compound loop control to ratio control or residual only control via digital input 1, 2 or 3 available

$$\text{Yout} = \text{Wq} \times (\text{DF}_{\text{Wq}} + \text{ek} \times \text{Kp} \times (1 + \text{t}/\text{tn})) \times \text{Yout factor}$$

Ratio
Feedback control

| | |
|------------------------|--|
| <i>t</i> | <i>Internal controller cycle time</i> |
| <i>tn</i> | <i>Integral action time</i> |
| <i>Kp</i> | <i>Control amplification 100 / Xp</i> |
| <i>ek</i> | <i>Setpoint-actual value</i> |
| <i>DF_{Wq}</i> | <i>Learned dosing factor for the current flow rate</i> |
| <i>Wq</i> | <i>Flow rate signal in %</i> |
| <i>Yout</i> | <i>Determined controller output value %</i> |
| <i>Yout factor</i> | <i>This factor gives the option of increasing the dosing output by a dosing factor DF of 100% when the setpoint value is not reached.</i> <i>Increase the dosing output.</i> <i>Setting range: 1.0– 4.0</i> <i>Factory setting: 1</i> |

NOTE: If Yout factor is increased > 1, there is a danger that the setpoint value will also not be reached with a higher flow rate value, because the Yout value takes the value 100 % prematurely.

Determining Compound Loop Control Process Times

To adjust the control for compound loop control, the Tconst and Tvar process times must be entered in the parameter menu path. These times refer to control loop dead times, which on the one hand are independent of the control variables, and on the other hand depend proportionally on the control variables.

The constant dead time < Tconst > (independent of control variable) consists of the control variable measurement dead time (measuring dead time) and possible dosing delays.

The variable dead time $\langle T_{var} \rangle$ depends on the current control variable and is entered in the menu at a control variable of 100%.

The following calculation examples apply for the use of the SFC for flow-controlled chlorine dosing with chlorine overfeed correction (potable water control loop).

Determining the Control Variable Independent Dead Time T_{const}

The control variable independent dead time T_{const} consists of the measuring dead time and the dosing dead time.

Calculating the Measuring Dead Time

Calculation 1:

The sample water is extracted right after the mixture loop and fed to the measuring cell.

The sample water dead time depends on the nominal diameter and length of the sample water line and the flow rate to the measuring cell. A flow rate of 36 l/h is assumed for the Depolox® 5 measuring cell.

The following equation applies to the Depolox® 5:

$$t_{mw}(\text{Depolox}^{\circledR} 5) = (d_{mw} \times d_{mw} \times l_{mw}) : 7.65 \text{ (result in min)}$$

In general, this equation applies:

$$t_{mw} = (4.71 \times d_{mw} \times d_{mw} \times l_{mw}) : Q_{mw} \text{ (result in min)}$$

d_{mw} = Internal diameter of the sample water line in cm

l_{mw} = Length of the sample water line in meter

Q_{mw} = Flow rate to the measuring cell in l/h

Example

The sample water line is 10 m long and connected to a Depolox® 5 chlorine measuring cell.

$$t_{mw} = (0.6 \times 0.6 \times 10) : 7.65 \text{ min} = 0.47 \text{ min, (i.e. approx. 28 sec.)}$$

Calculation 2:

The sample comes from the sample water pump (bypass line).

Sample water dead time depends on the flow rate of the sample water pump, nominal diameter of the bypass line and its length up to the sample water branch pipe to the measuring cell.

$$T_{by} = (4.71 \times d_{by} \times d_{by} \times l_{by}) : Q_{by}$$

- d_{by} = Internal diameter of the bypass line in cm
- l_{by} = Length of the bypass line from the sample water extraction point to the sample water branch pipe to the cell in m
- Q_{by} = Flow rate to the bypass pump in l/h (result in min)

Check whether the length of the sample water line to the measuring cell can be neglected. If so, establish the sum from calculation 1 and 2.

Calculation 3:

The sample water distraction is carried out as in calculation 1 and/or 2. To increase the exposure time, the sample water is also sent through a delay tank.

The exposure time in the delay tank must be added to the calculated time.

Determining the Dosing Dead Time (Dosing Delay)

Dosing dead times arise from long dosing lines and positioner running times.

Calculation 1:

Determining the dead time based on dosing line length

The dosing dead time can be determined as follows:

$$t_{dos} = (4.71 \times d_{dos} \times d_{dos} \times l_{dos}) : Q_{dos} \text{ (result in min)}$$

- d_{dos} = Internal diameter of the dosing line in cm
- l_{dos} = Length of the dosing line in m
- Q_{dos} = Dosing line flow rate in l/h

Calculation 2:

If rapid control variable changes are expected in the system, which the dosing equipment cannot adjust to (e.g. positioner running times, dosing pump cycle times), the dosing delay time should be assumed under all circumstances to be half of the positioner running time t_p or the cycle time t_{cp} .

At a positioner running time of 80 seconds, a value of approx. 40 s should be assumed as the constant dosing delay.

The sum of the measured dead time and the dosing delay is displayed in the < Tconst > menu in minutes.

Determining the Control Variable Dependent Tvar Dead Time

The control variable dependent Tvar dead time depends on the nominal flow rate, the internal diameter of the line and the distance between where the chlorine is added and the sample water extracted.

$$t_{\text{var}} = (d_{\text{pipe}} \times d_{\text{pipe}} \times l_{\text{pipe}}) : 212.3 \times Q_{\text{nom}} \quad (\text{result in min})$$

d_{pipe} = Internal diameter of the pipeline in cm

l_{pipe} = Distance between where chlorine is added and sample water extracted in m

Q_{nom} = Nominal flow rate in m³/h (reflects the flow rate, which is preset for the controller as 100% flow signal)

If there are special reaction tanks in the system, they must be treated separately.

3.4.3 Application 3 - Ratio Control without Process measurement

In application 3, the SFC operates exclusively as a ratio control. The installation of a sensor measuring module is not supported in this application.

The dosing capacity of the connected device is controlled automatically, depending on a measuring signal (external flow rate control signal) and a settable dosing factor. When actuators with feedback are involved, it is possible to adjust the non-linearity using a maximum of 11 calibration points.

Application 3

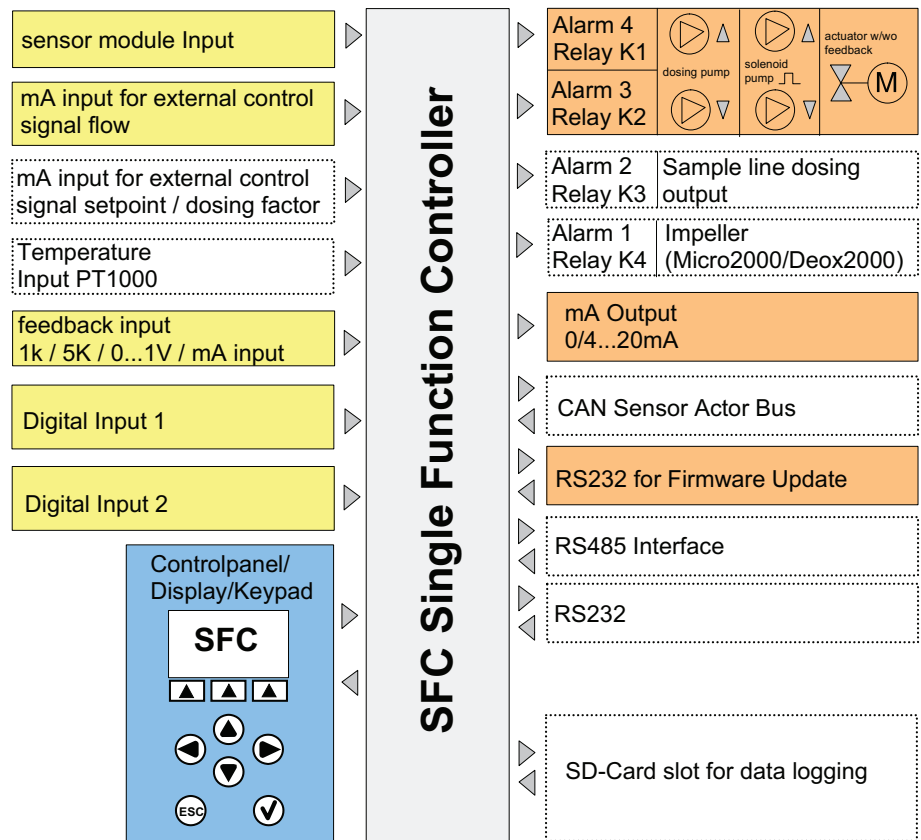

..... The features with dotted lines are included as an option

Figure 3.8 - Application 3

Ratio Control without Process Measurement

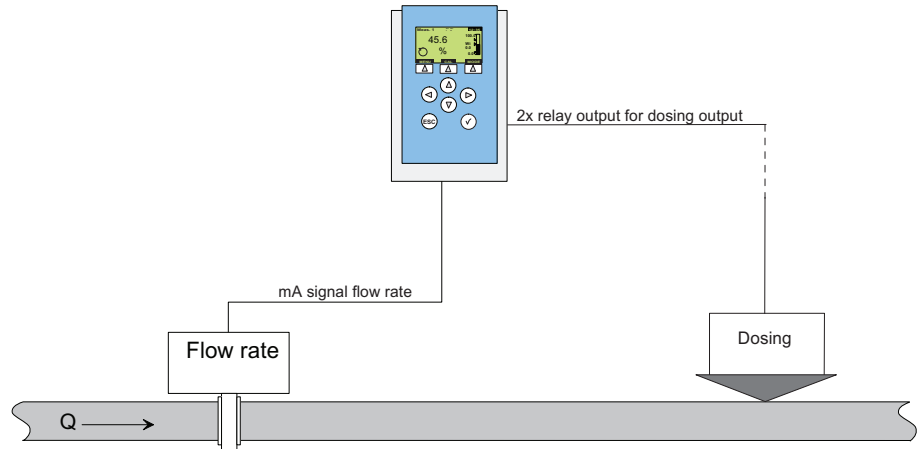

Figure 3.9 - Sample application of SFC as ratio control

Required module configuration:

Sensor measuring modules for measured value recording, e.g., of Cl_2 , pH, etc., are not supported or evaluated in this application.

Input signals:

- Flow rate measurement (0/4 – 20mA) scalable

The following dosing outputs are possible:

- Dosing pump
- Pulse pump
- Positioner with feedback 1kOhm/5kOhm/0 –1 V/mA signal
- mA analog output

Ratio Control without Process Measurement Theory of Operation

The flow rate is recorded and the dosing capacity adjusted proportionally to the flow rate using the flow rate sensor with linear mA output signal. On the settings for the flow rate signal see menu "Inputs/Outputs" - "Flow Wq".

NOTE: If the measuring range end value of the flow meter is not identical with the actual maximum flow rate, a factor for adjusting the flow rate signal should be input in the menu "Inputs/Outputs" - "Flow Wq".

For example: Measuring range flow meter = 5000 l/h / max. flow rate = 2500 l/h => factor = 5000: 2500 = 2.0

The relationship between control variable and dosing output is determined by the internal dosing factor.

If a positioner with feedback is used as the dosing output, it can be linearized using several support points. At least two points are required (0/100 %). It is possible to define 2, 3, 6 or 11 support points with definite steps. In the menu "Dosing" - "Ym Calib. Points" the number can be defined. The support points then have to be set in menu "Dosing" - "Ym Calib. Manual" (see section 4.4.3 - Positioner Calibration with SFC (application 3) or ratio control (application 2)).

The controller output is calculated in this operating mode as follows:

$$Y_{out} = W_q \times DF$$

W_q - Control variable 1 flow rate in %

DF - Set dosing factor in %

The figure below shows the output dosing capacity depending on the flow rate W_q and the set dosing factor.

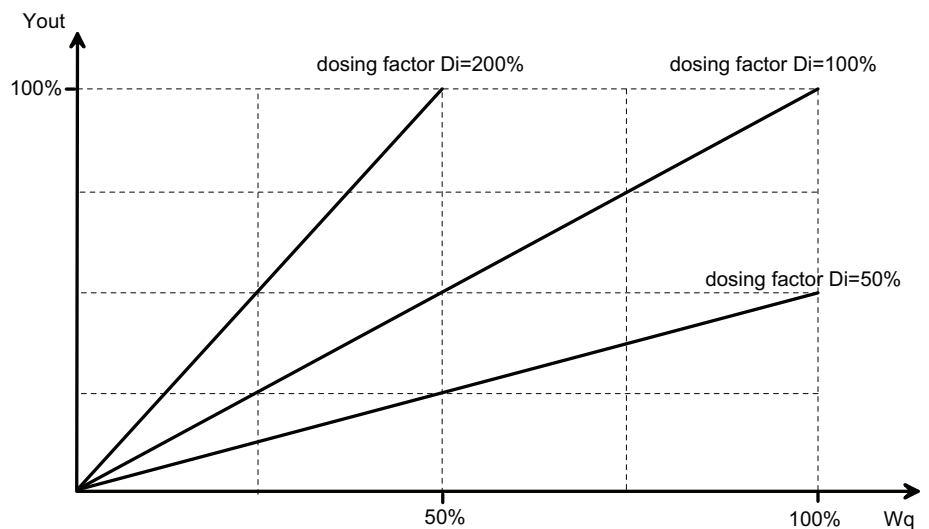

Figure 3.10 - Dosing factor

3.5 Controller Outputs

3.5.1 Controller Types

| Controller For | Type | Parameter Description | Action |
|--|---------|-----------------------|---------------|
| Positioner with feedback | 3-point | Positioner with Ym | Dosing ↑ or ↓ |
| Positioner without feedback | 3-point | Positioner without Ym | Dosing ↑ or ↓ |
| Motor dosing pump (pulse duration controller) | 2-point | Dosing pump 2p | Dosing ↑ or ↓ |
| 2 Motor dosing pumps (pulse duration controller) | 3-point | Dosing pump 3p | Dosing ↑ or ↓ |
| Pulse pump (pulse frequency controller) | 2-point | Pulse pump 2p | Dosing ↑ or ↓ |
| 2 Pulse pumps (pulse frequency controller) | 3-point | Pulse pump 3p | Dosing ↑ or ↓ |
| Dosing pump with mA-input | 2-point | Analog output 2p | Dosing ↑ or ↓ |
| 2 Dosing pumps with mA-input | 3-point | Analog output 3p | Dosing ↑ or ↓ |
| Dosing contact | 2-point | Enable contact | Dosing ↑ |

3.5.2 Positioner (With and Without Feedback)

With the selection of the integrated controller for “positioner”, for example, it is possible to use chlorine overfeed control in connection with a positioner as dosing equipment in a chlorinator.

If positioner feedback is available, it must be calibrated during commissioning. Potentiometer 1 kOhm/5 kOhm or 0 – 1 V or 0/ 4 – 20 mA signals can be connected as positioner feedback (see section 3.12 - Actuator feedback).

3.5.3 2-Point Pulse Duration Controller for Dosing Pumps

The dosing pump is switched on for the calculated time within an adjustable cycle period TP (relay contact). The cycle period is mainly determined by the reaction time of the connected system and entered as the cycle period TP.

Example: Cycle period TP = 100 s
 Output value Yout = 30%
 Duty cycle = 30 s
 Off duty cycle = 70 s

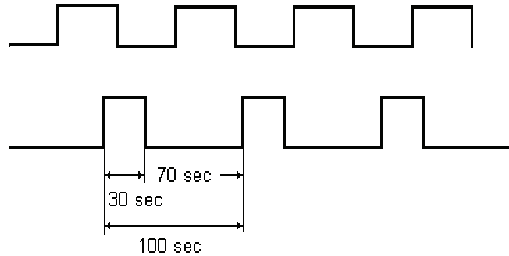

Figure 3.11 - Cycle period

3.5.4 2-Point Pulse Frequency Controller For Pulse Pumps

Pulse pumps are controlled with 0 to 100 or 0 to 120 pulses per minute, depending on the specification of the connected pump.

The duty cycle during each dosing is 0.3 s. The break time is calculated between 0.2 and 60 s depending on the dosing rate.

Example for a solenoid pump with 120 pulses/min.:

| | | | | | | | | | | |
|------------------------|--------|-------|-------|----|-------|-------|-------|-------|------|----|
| Yout in % | 100... | 84... | 72... | 56 | 50... | 33... | 25... | 10... | 5... | 10 |
| Pulses/ min | 120... | 96... | 85... | 75 | 60... | 40... | 30... | 12... | 6... | 10 |

3.5.5 3-Point Pulse Duration Controller for Dosing Pumps and 3-Point Pulse Frequency Controller for Solenoid Pump

Pump 1 decreases the control value.

Pump 2 increases the control value.

The control range is between -100% (pump 1) and +100% (pump 2); this range can also be set in manual mode.

If the setpoint = actual value, no pump is activated (neutral zone Xsh).

Output signals as for 2-point pulse-duration controller and 2-point pulse-frequency controller.

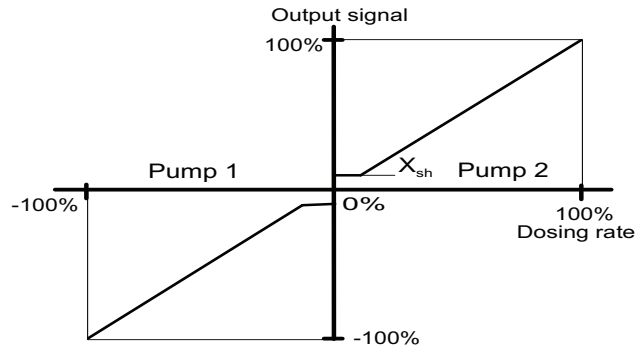

Figure 3.12

3.5.6 Dosing Factor (e.g. For Electrolysis Systems)

A special controller is required for controlling electrolysis units to prevent excessive on/off switching (on account of the response times of the electrolysis unit).

This controller output, therefore, uses a minimum duty cycle as well as a switching hysteresis to minimize the switching cycles.

If the value falls below the specified Cl_2 setpoint minus hysteresis (e.g. setpoint 0.50mg/l - hysteresis 0.05 = 0.45mg/l), the controller output switches on. The controller output remains active for at least the set minimum duty cycle. If the setpoint is exceeded and the minimum duty cycle has expired, the contact switches off.

The minimum duty cycle is ignored in manual mode.

3.5.7 Controller With mA Output

The SFC has an analog mA output. This can be assigned as a registration or controller output.

If pH dosing “analog output.2p” or “analog output.3p” is selected, the output is permanently assigned.

3.5.8 Analog Output Controller 2-Point

With a controller output of 0%, the output current is 0 or 4mA; with a higher controller output, the output current reaches up to 20mA. Pumps with current input, thyristor controllers with DC or 3-phase pumps or analog control valves can be used as dosing equipment.

3.5.9 Analog Output Controller 3-Point

Pump 1 decreases the control value.
 Pump 2 increases the control value.

Output behavior is similar to “analog output controller (2-point)”, but with 50% offset. This means that with a control deviation of 0% (setpoint = actual value) a current of 10 or 12 mA is output (pump is idle).

| Setting | Signal | Pump | Signal | Pump |
|---------|-----------|--------|----------|--------|
| 0–20 mA | 0–0.10 mA | Pump 1 | 10–20 mA | Pump 2 |
| 4–20 mA | 4–0.12 mA | Pump 1 | 12–20 mA | Pump 2 |

Therefore, 2 suitable pumps can be controlled with one mA current loop.

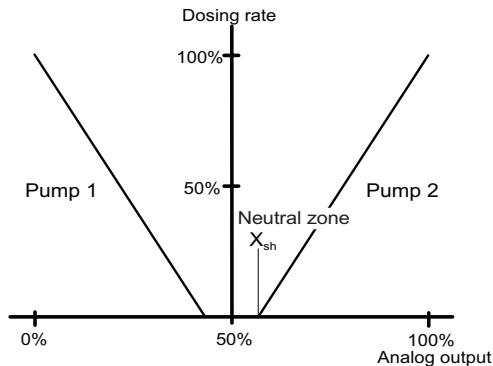

Figure 3.13

3.6 Control Parameters

Control parameters and setting values for determining the control functions of a controller. Different parameters apply for each controller type.

NOTE: The control parameters are listed alphabetically.

Flow Rate Source

This parameter is only available during ratio control in application 2.

This parameter switches off the flow input (off) and activates the flow rate signal for the ratio control (factory setting = flow measurement) as control variable.

The parameter must be set to “Flow Measurement” for quantity-proportional dosing.

Flow Rate Direction

This parameter determines the direction of the flow rate signal directly proportional to the actuator output:

Direct = flow rate input signal directly proportional to actuator output (factory setting).

Inverse = 1 flow rate input signal

Example: 0–100% flow rate = 0–20 mA (direct).
0–100% flow rate = 20–0 mA (inverse).

Max. Pulses/Min

Meaning: Maximum number of pulses.

Explanation: The pulses max./min parameter only applies to solenoid pumps.

This parameter is used to set the maximum number of pulses per minute in accordance with the employed pump.

Setting range: The parameter max. pulses/min can be set at either 100, 120, 140, 160, or 180 pulses.

Max.lin.Corr

This parameter monitors changes to already learned dosing factors. If new dosing factor changes are learned, which are larger than the max. linearity correction, this dosing factor is used for all values in the dosing curve => initialization of the curve.

Max.lin.Corr. = 0: No curve function; only one dosing factor for all flow rates.

Example:

Max.lin.Corr. = 50% (based on dosing factor):

Previous dosing factor: 30%

Newly learned dosing factor: 48%

max. permissible correction range: $30 \pm (50\% \text{ from } 30\%)$
 $= 30\% \pm 15\%$

Change in this case: $48\% - 30\% = +18\%$

=> The new dosing factor is assumed for the entire curve because the new dosing factor (+ 48%) is greater than the max.lin.Correction (+18%).

Control Factor

Setting the ratio of control range and measuring range, in order to adjust the control amplification X_p to the process.

Control factor =
(End of measuring range - start of measuring range): Control range

Example:

Start of measuring range: pH 4

End of measuring range: pH 9

Max. process control range: ± 1 pH (\Rightarrow 2 pH increments)

\Rightarrow Control factor =

$(9 - 4) : 2 = 2.5$

Control Direction

Meaning: Direction of the control.

Display: Direct/inverse (e.g. for pH).

Explanation: Defines which medium is used to perform the correction.

Example:

pH: Control direction "inverse": Lowering pH-value by adding acid.

pH: Control direction "direct": Adding alkaline to raise the pH value.

Setpoint

Specified value at which the control variable can be maintained by the controller. The setting range corresponds to the respective measuring range.

Control Variable 2

This parameter activates and deactivates a second control variable during the ratio control (only with application 2).

If "Control Variable 2" = measured value X is selected, this influences the actuator output. The setting "Off" indicates this control variable is inactive (factory setting) (see section 3.4.2.1, Ratio Control with Process Measurement).

T

Sampling time T is the time after which a change control variable or set-point is responded to. This value must be adjusted in the case of delayed feedback signals.

Tconst

Defines the constant dead time in the combi-controller loop. Consists of the sample water line dead time and the dosing delay time (for the calculation, see section 3.4.2.1, Compound Loop with Process Measurement).

Tn

| | |
|----------------|--|
| Meaning: | Integral action time (I-element). |
| Display: | Minutes (min). |
| Explanation: | On the basis of the integral action time T_n , the dosing capacity changes constantly until the setpoint is reached. The higher the value of T_n , the longer it takes until the controller increases the dosing rate. |
| T_n higher: | Control response is slower. |
| T_n lower: | Control response is faster. |
| Setting range: | The parameter T_n can be set from 0–100 min ($T_n = 0$ means that the “I-element” is deactivated, i.e. a pure P-control response applies). It may not be possible to reach the setpoint value. |

Tp

| | |
|----------------|---|
| Meaning: | Cycle period. |
| Display: | Seconds (s). |
| Explanation: | The parameter T_p only applies to dosing pumps. The cycle period T_p defines a switching period, which must be coordinated with the respective pump type. |
| Setting range: | The parameter T_p can be set from 10–180 s. |
| Example: | Fast dosing pumps correspond to a low T_p ; slow dosing pumps correspond to a high T_p . |

SFC-PC CONTROLLER

The control parameter T_p must always be adjusted to suit the pump employed:

| Dosing pump strokes/min | up to 20 | 20-40 | 40-80 | 80-125 | 125-200 |
|-------------------------|----------|-------|-------|--------|---------|
| T_p value | 120 | 100 | 60 | 30 | 15 |

T_s

Meaning: Loop rise time.

Display: Minutes (min.).

Explanation: Time required to reach the measuring range end value with 100% dosing chemical supply (see section 3.8, Adaption).

Setting range: The parameter T_s can be set from 1 s – 8 h.

NOTE: If the values T_u and T_s are manually modified, the control parameters X_p and T_n are re-calculated.

T_u

Meaning: Loop dead time.

Display: Seconds (s).

Explanation: Time required between dosing start and clear recognition of the rise in the control variable.

Setting range: The parameter T_u can be set from 1 s – 59 min 59s.

NOTE: If the values T_u and T_s are manually modified, the control parameters X_p and T_n are re-calculated.

T_{var}

Defines the variable dead time in the combi-controller loop. The time to be entered is based on 100% flow rate (for the calculation, see section 3.4.2.1, Compound Loop with Process Measurement).

Ty

Meaning: Running time of the positioner.

Display: Seconds (s).

Explanation: The parameter Ty only applies to positioners.

Ty is the time which the positioner requires to adjust from 0% to 100%.

Setting range: The parameter Ty can be set from 10–180 s.

X Factor

This parameter is only available during ratio control, control variable 2 = measured value X.

Determines an adjustment factor, how strongly the measured value influences the actuator output (factory setting 1.0).

Xp

Meaning: Proportional factor.

Display: Percentage (%) with factor.

Explanation: The control amplification is determined with the proportional factor.

The lower the proportional factor Xp is selected in %, the greater the deviation from the setpoint is amplified, and the more quickly the controller attempts to control the deviation from the setpoint.

The control amplification factors is calculated using the following formula:

$$\text{Factor} = (1/Xp) \times 100 \%$$

Setting range: The parameter XP can be set from 1 % (factor 100) – 1000 % (factor 0.1).

X Direction

Determines the direction of the second control variable during the ratio control.

Direct = measured value directly proportional to the actuator output

inverse = actuator output indirectly proportional to measured value (factory setting = direct)

Xsh

Meaning: Neutral zone.

Display: Percentage (%).

Explanation: The parameter Xsh only applies to 3-point controllers.

No controller output occurs in the neutral zone.

Setting range: The parameter Xsh can be set from 1–5% (depending on the measuring range).
The neutral zone is the defined range of setpoint + X_{sh} to setpoint X_{sh} .

Ym Calibration

This parameter is only possible for dosing output positioner with feedback.

Adjust the positioner feedback signal to 0% and 100% dosing capacity. When automatic Ym calibration is started, the positioner moves to positions 0% and 100% and calibrates both positions with the SFC.

With manual calibration of the up-to-11 positions, all positions must be shifted to manually and saved in the menu using the Enter key.

Ymax

Meaning: Dosing rate limitation (single feedback control-loop control only).

Display: Percentage (%).

Explanation: The parameter Ymax only applies to:

- Positioner with feedback
- Dosing pumps
- Solenoid pump
- Controller with mA output

Ymax defines the maximum control output to the actuator

The control parameter corresponds to electronic dosing limitation of the actuator.

Setting range: The parameter Ymax can be set from 0–100%.

Ymin

Meaning: Dosing rate basic load (single feedback control-loop control only).

Display: Percentage (%).

Explanation: The parameter Ymin only applies to:

- Positioner with feedback
- Dosing pumps 2p
- Solenoid pumps 2p
- Controllers with mA output 2p

A basic dosing rate is output to the actuators with Ymin.

Setting range: The parameter Ymin can be set from 0–100%.

NOTE: Ymin and Ymax is only available for the single feedback closed-loop control. The control range is limited by the parameters Ymax and Ymin. Do not select a Ymax value lower than Ymin. At Ymin > 0 overdosing can occur.

Yout-factor

| | |
|----------------|--|
| Meaning: | Multiplication factor for dosing output. |
| Setting range: | The parameter Yout factor can be set from 1.0 - 4.0. |
| Explanation: | If the dosing factor 100% is not sufficient, the parameter Yout factor is used to increase the dosing output. The parameter is available with combi-control and ratio control. |

3.7 Alarms

The output of the alarms takes place by means of relay contacts and alarm indicators on the display. The number of the max. four alarms is determined in the application or by the version of SFC.

Each alarm can be assigned the following functions:

| | |
|---------------------------|---|
| Limit value = Min | All measured values are individually selectable Cl ₂ , pH, mV, Cl-N, conductivity, etc. |
| Limit value = Max | All measured values are individually selectable Cl ₂ , pH, mV, Cl-N, conductivity, etc. |
| Digital inputs | 1 to 2 can be selected individually |
| Error | |
| Flow rate min/max | |
| ext. Setpoint/DF min, max | |
| Yout min/max | |
| Manual mode | |
| Ypi min/max | |

The type of alarm can be selected in the “Alarms” menu in the displays “Alarm ... Functions” displays. There are three types of alarms.

In all alarm types the response can be influenced by entering a delay (td) (refer to the diagrams in this chapter).

3.7.1 Unlatched Alarm Without Acknowledgement Option (N.O. Unlatched, N.C. Unlatched)

The alarm symbol on the display is on when an alarm is triggered and goes out automatically when the alarm condition is removed. The same applies for the contact.

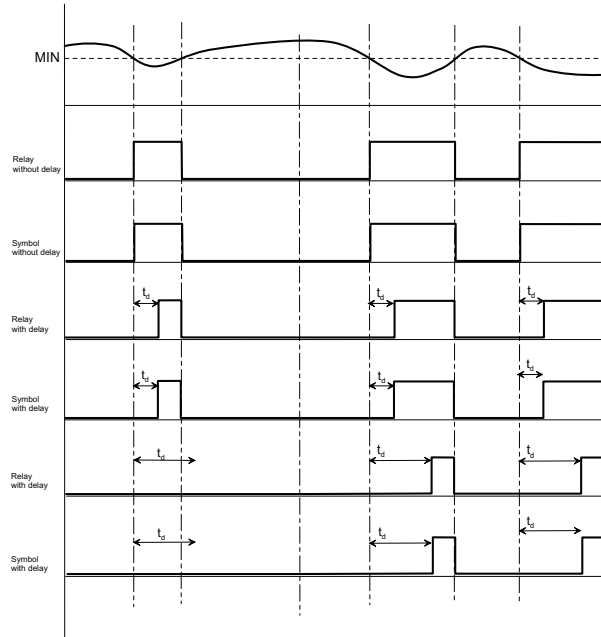

Figure 3.14 - Example MIN alarm

3.7.2 Latched Alarm With Reset Acknowledgement Option (N.O.Latched Reset, N.C.Latched Reset)

In the even of an alarm, the alarm symbol on the display flashes until the alarm is scknoledged. The LED also goes out even if the alarm conditions still apply when the alarm is acknoledged.

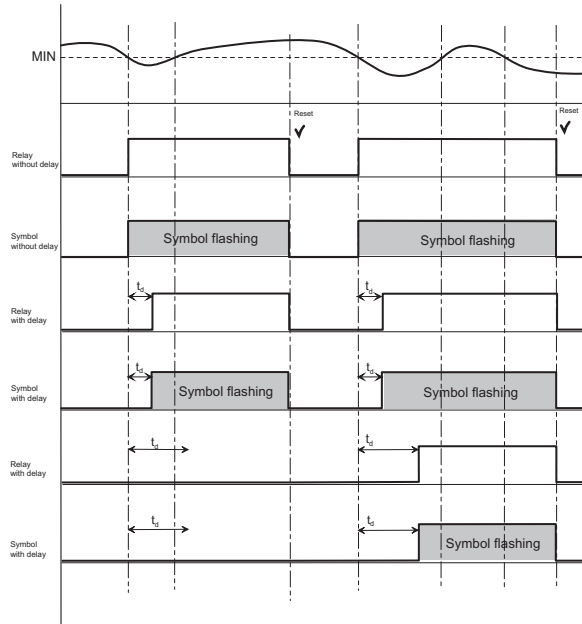

Figure 3.15 - Example MIN alarm

3.7.3 Latched Alarm With Confirmation (Acknowledgement Option) (N.O. Latched Ack., N.C. Latched Ack.)

In the event of an alarm, the alarm symbol on the display flashes until the alarm is acknowledged.

- If the alarm condition is no longer present when the alarm is acknowledged, the symbol disappears.
- If the alarm condition is still present when the alarm is acknowledged, the symbol is reset from flashing to a permanent state. The symbol or the contact is active until the alarm condition has been removed (auto-reset).

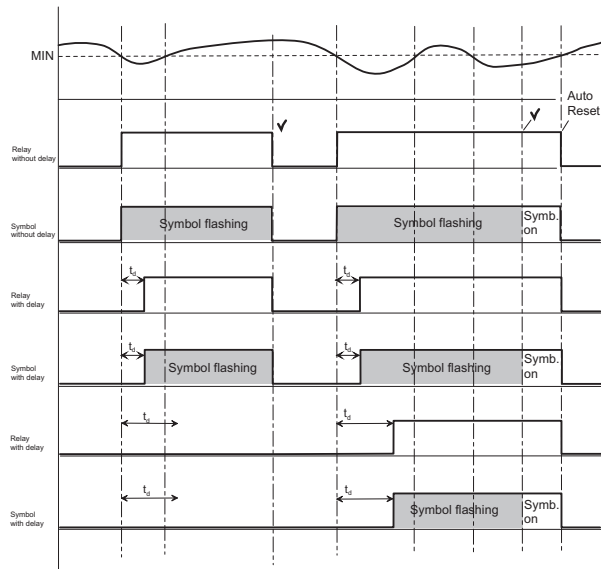

Figure 3.16 - Example MIN alarm

3.8 Adaption

This only applies to Cl_2 single feedback closed-loop control.

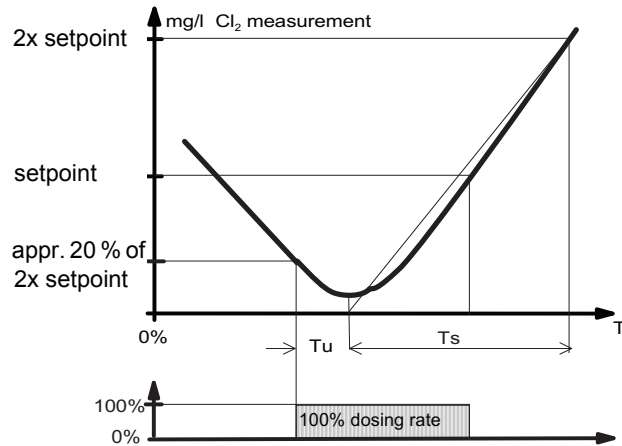

Figure 3.17

3.8.1 Application

Adaption is used for automatic determination of the reaction times of the control loop (loop dead time T_u and loop rise time T_s) or the resulting control parameters X_p and T_n .

NOTE: The control parameters X_p and T ascertained by the adaption must be considered as a recommendation for the first startup. The control parameters X_p and T can be manually optimized to ensure maximum control quality.

3.8.2 Requirements

- Positioner set to automatic (manual wheel engaged) Dosing pump set to automatic
- Calibrated Cl_2 measurement (zero point and span value)
- Loop dead time < 60 min
- Loop rise time < 480 min (8 h) for 0–100% measuring range
- Decomposition time < 480 min (8 h) of the current value to 20% of the measuring range
- Correct menu setting of the end value, control direction (direct or inverse), actuator (e.g. positioner), positioner running time (T_y)

Adaption may not be started:

- If a large volume of fresh water is added
- If the chlorine sensor has not been run in
- During cleaning work
- During filter backwashing
- When the circulation changes
- If there are flow rate fluctuations

3.8.3 Starting Adaption

1. Starting from the basic display, select "Adaption" from the "Cl₂free ()" menu.
2. In the "Adaption" menu, select the "ADAPT" softkey.
3. This displays the current chlorine value, the actuator output Ym/Y and the control variable in %. The diagram of the previous adaption is shown when the key → is pressed.
4. Press "START" to start the adaption. Adaption starts.
5. Adaption can be cancelled using the "Cancel" softkey.

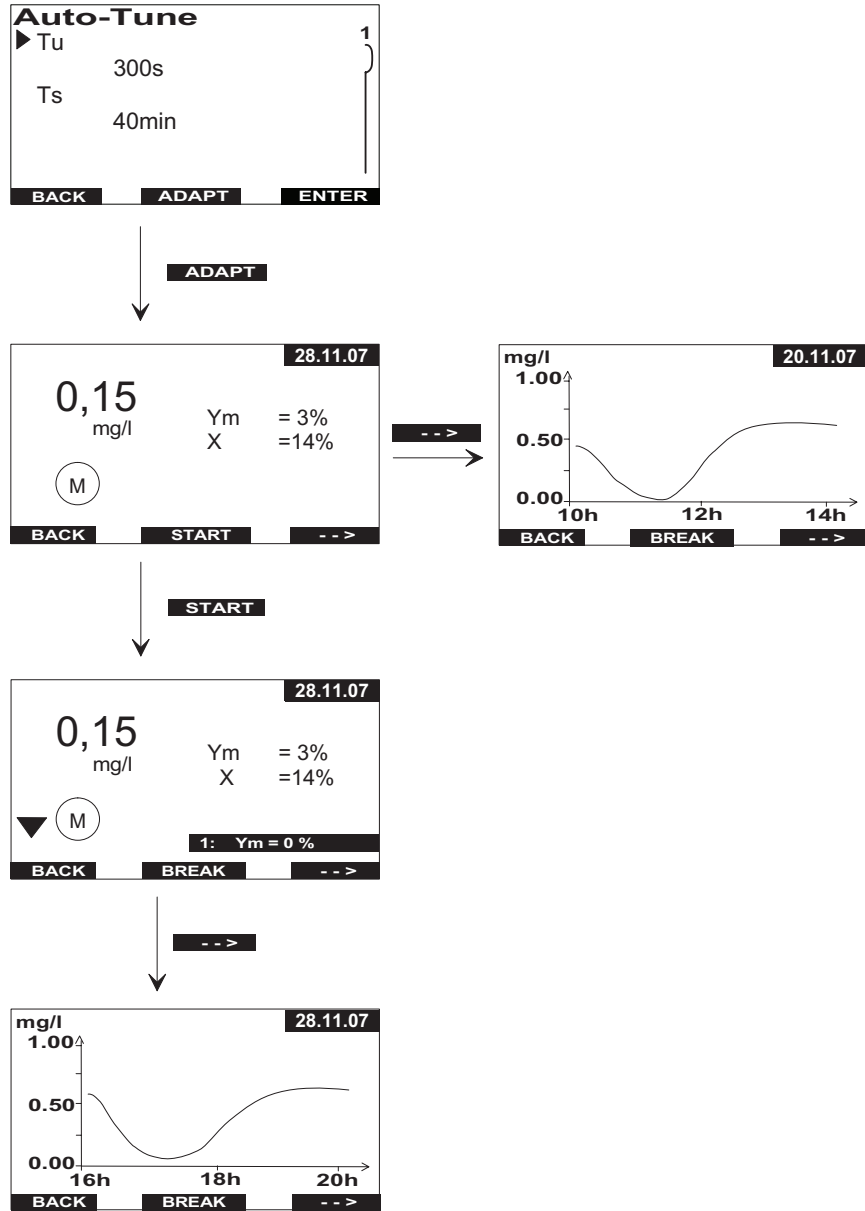

Figure 3.18 - Adaption displays

3.8.4 Displays

The diagram shows the chlorine value curve during the adaption phases. The current phase of adaption (total of 13) is shown in the bottom line.

Successful adaption is confirmed by the "ADAPTION OK" message.

Press the "BACK" softkey to return to the basic display.

If adaption is not successful, the error message "ADAPTION?" is displayed.

3.8.5 Adaption Sequence

Each adaption phase is then displayed with a status message:

| Display text | Explanation |
|-------------------|--|
| "0: Init" | Start |
| "1: Ym = 0%" | Chlorinator to 0% or dosing pump off |
| "2: X = 20%" | Delay until actual value < 0.2 x end value |
| "3: Ym = 100%" | Chlorinator to 100% or dosing pump on |
| "4: Ym = 100%" | Wait until the chlorinator reaches 100% |
| "5: Tu! " | Start dead time measurement |
| "6: Tu! " | Measurement of the loop dead time Tu |
| "7: Tu Check" | Plausibility enquiry dead time |
| "8: Init Ts" | Start of rise time measurement |
| "9: Ts " | Measurement of the loop rise time Ts |
| "10: TS " | Calculate control parameters |
| "11: Y = 0%" | Chlorinator to 0% or dosing pump off |
| "12: Y = 0%" | Wait until the chlorinator reaches 0% |
| "13: Adaption OK" | End |

Various status messages can be output, depending on the selection of the actuator. Different status messages also have different execution times. It is possible that several status messages are only displayed briefly or not at all if the execution time is very short.



CAUTION: Adaption can take up to 13 hours, depending on the control loop. During this time no errors should occur on the control loop (e.g. filter back-washing, changes in the circulation).

NOTE: The adaption procedure can be terminated at any time with "STOP". The previously set parameters remain unchanged.

3.8.6 Completing Adaption Without Errors

When the loop times (dead time Tu and rise time Ts) have been completed without errors, calculation of the control parameters Xp and Tn commences. This is indicated by the message "Adaption OK". The calculated parameters are entered into the menus. When adaption has been concluded, the measuring amplifier adjusts with the newly calculated control parameters and continues in the selected operating mode (e.g. automatic).

These are entered into the "Tu" and "Ts" menus to monitor the determined loop times.

If errors occur in the control loop during adaption, incorrect loop times and therefore incorrect control parameters can be determined.



CAUTION: The remaining control parameters Y_{min} , Y_{max} and T_p are not influenced when adaption is performed. The control parameters X_p and T_n are determined for $Y_{min} = 0\%$ (no basic load) and $Y_{max} = 100\%$ (no dosing rate limitation). If a basic load Y_{min} or dosing rate limitation Y_{max} are required for specific system requirements, it must be taken into account that the control loop is restricted as a result. There is then the risk of excessive chlorination (Y_{min} too high) or inadequate chlorination (Y_{max} limits excessively).

3.8.7 Completing Adaption With Error

If errors occur in the control loop during adaption (e.g. filter backwashing, changes in the circulation) or if the reaction times of the control loop are too long, adaption is interrupted.

Possible error conditions:

Initial value not reached (Display: “T = > 8h”)

When adaption has started and the dosing system has closed or the dosing pump has switched off, the measuring amplifier waits until the actual value has dropped below the initial value (0.2 x the measurement range value). This delay is indicated by the message “2: X = 20%” and the maximum permissible time is 8 hours.

Loop dead time too high (Display: “Tu = > 1h”)

The value determined by the time measurement between starting up the dosing, switching on the dosing pumps and the rise of the actual value may only take a maximum of 1 hour. This measured time is displayed by “6: Tu!”

Loop rise time too high (Display: “Ts = > 8h”)

The time is determined by a measurement, which the control loop requires at a 100% dosing rate of the dosing system or the dosing pump, to increase the actual value to 50% of the measuring range. This measurement is indicated by the message “9: Ts!” and may take up to 4 hours.

If any of the error conditions described above occur, adaption is interrupted. The measuring amplifier indicates an error message. The “old” parameters X_p and T_n are not changed.

3.8.8 Determination of the Control Parameters With Known T_u and T_s Times

If the loop times T_u and T_s are already known or if these cannot be determined automatically due to specific system conditions, the loop times can be entered into the “ T_u ” and “ T_s ” menus. When T_u or T_s are saved, the control parameters X_p and T_n are also calculated and entered into the menus.

3.9 Serial Interfaces

Various interfaces are available to externally link the SFC.

3.9.1 RS232

The RS232 interface serves to connect:

- A laptop or PC for a Firmware update (Download the latest firmware version with an update program and update instruction from the Wallace & Tiernan homepage (www.wallace-tiernan.de). Matching RS232 connecting cable: Ref. W2T320242).

3.9.2 RS485

The RS485 interface provides connectivity to:

- Web technology via Wallace & Tiernan® ChemWeb server
- Higher level visualisation systems through OPC Server Data Access V2.0
- Visualization systems under Windows® TM via Wallace & Tiernan® CMS software 3.0
- SECO S7 - Serial data link to SIMATIC S7-300
- External gateways

The SFC RS485 interface is electrically isolated. To integrate into a Evoqua Water Technologies bus system, four terminal strips, a terminating resistor R_t and balancing resistor R_u and R_d are integrated into the SFC.

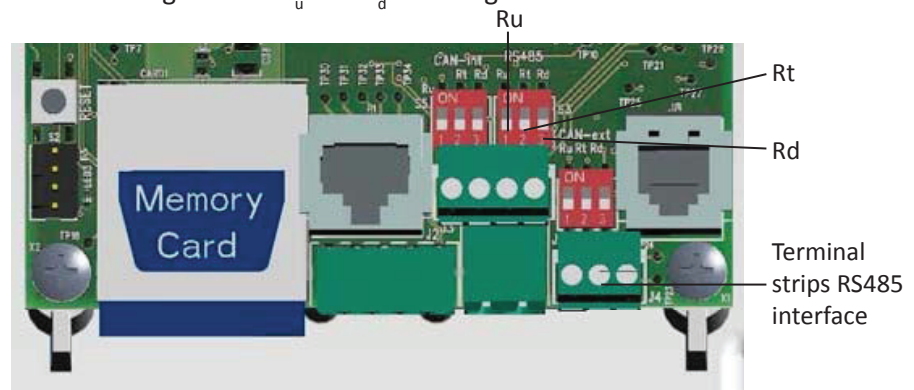

Figure 3.19 - Front panel board

To illustrate the CAN functionality, two examples for CAN applications are listed below:

Example 1

An SFC (master) is operated with a CAN actuator dosing pump in a CAN installation.

Both units must be operated in the same segment. In the following example, segment 1 is used, it could, however, be any segment from 1 -31. The following device settings are required:

| | |
|---|------------------|
| SFC-Cl ₂ : | |
| Menu - Inputs/Outputs - Interface - "CAN segment": | 1 |
| Menu - Cl ₂ free - Dosing - "Dosing output": | CAN-Bus actuator |
| Menu - Cl ₂ free - Dosing - "CAN address": | 2 |

| | |
|---|---|
| CAN dosing pump: | |
| Menu - Configuration - CAN Bus: | ✓ |
| Menu - Configuration - Segment address: | 1 |
| Menu - Configuration - Slave address: | 2 |
| Menu - Configuration - Bus termination: | - (only with the last and first units of the bus installation ✓) |

Example 2

An SFC-Cl₂++ (master or slave) is installed with an SFC pH, in order to compensate the chlorine measurement with the pH value. In this application, both units need not be operated in the same segment. In the following example, segment 1 is used and the following settings must be carried out.

| | |
|---|---|
| SFC-Cl ₂ ++: | |
| Menu - Inputs/Outputs - Interface - "CAN segment": | 1 |
| Menu - Cl ₂ ++ - Measuring range - "CAN address pH": | 2 |

| | |
|--|---|
| SFC-pH: | |
| Menu - Inputs/Outputs - Interface - "CAN seg. (Sens)>": | 1 |
| Menu - Cl ₂ ++ - Measuring range - "CAN addr. (Sens)>": | 2 |

A bus end (bus termination Rt) must be installed at the first and last units in the bus. Some units have a dip switch Rt (e.g. SFC see image). Other units require a menu setting that activates the bus termination.

Balancing of the CAN bus must take place once in the CAN bus. For this purpose, there are dip switches for Ru and Rd integrated in the Ru and Rd SFC in the immediate vicinity of the CAN terminal. By means of the dip switches, resistances can be turned on or off (see front panel board in the cover of the SFC).

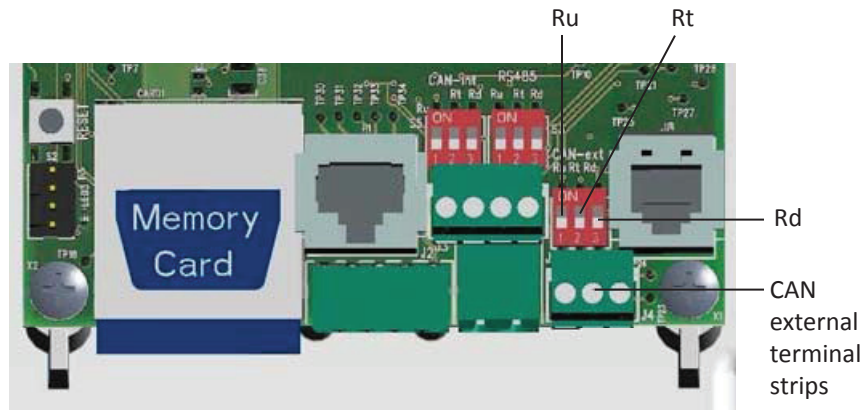

Figure 3.21 - Front panel board

3.11 Serial Firmware Update

Via the serial interface of a laptop/PC, it is possible to update the firmware of the SFC. A special download software and the latest firmware including a description can be downloaded from the Wallace & Tiernan homepage at www.wallace-tiernan.de. A special update cable is available for the firmware update under order no. W2T320242.

3.12 Actuator feedback

The actuator feedback of the SFC is set at the factory to potentiometer with 1 kOhm. For other feedback signals the device must be reset using the DIP switch S4 (see IC board).

Possible signals are:

- Potentiometer 1 KOhm
- Potentiometer 5 KOhm
- 0/4–20mA signal
- 0–1V signal

Switch settings of DIP switch S4:

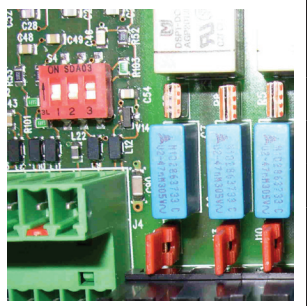
| | S2-A 1 | S4-B 2 | S4-C 3 | |
|------------------|-----------|-----------|-----------|--|
| Potentiometer 1K | Off | Off | On |  |
| Potentiometer 5K | Off | Off | Off | |
| 0/4-20mA | On | On | Off | |
| 0-1 V | On | On | Off | |

3.13 Digital Inputs

Two digital inputs are integrated in the IC board of the SFC. These are provided for connecting voltage-free contacts (< 100 Ohm) and are supplied internally with 12 V.



WARNING: NO VOLTAGE MAY BE APPLIED TO THE DIGITAL INPUT TERMINALS!

3.14 SD Memory Card

The SFC can optionally be equipped with an SD memory card for saving or copying unit configurations (see section 3.15, Unit Configuration) and for recording measured data. Every minute, all measured values, such as the main measurement (e.g. Cl₂, pH, etc.), flow rate, external setpoint or dosing factor, actuating variable Yout and temperature, along with the date and time, are saved on this card. The data are stored in files every month and have the following format:

The SD card is installed inside the SFC. In order to remove or replace the SD card, the cover of the SFC must be opened.

SFC-PC CONTROLLER

Example:

D200711.DAT
 ↗ ↖
 Year 2007 Month 11 (November)

The data can be further processed using any text editor or table processing program, such as EXCEL. The SD memory cards can be read-out and the data copied by any standard card reading device or PC.

Example of a file section:

| Date | | MW-mg/l | Wq | Wext./DF | Yout | Temperature |
|------------|-------|---------|------|----------|------|-------------|
| 2008-01-01 | 00:01 | 0.21 | 20.1 | 0.0 | 10.1 | 19.1 |
| 2008-01-01 | 00:02 | 0.21 | 20.1 | 0.0 | 10.1 | 19.1 |
| 2008-01-01 | 00:03 | 0.22 | 20.0 | 0.0 | 10.1 | 19.1 |
| ... | | | | | | |
| ... | | | | | | |
| ... | | | | | | |

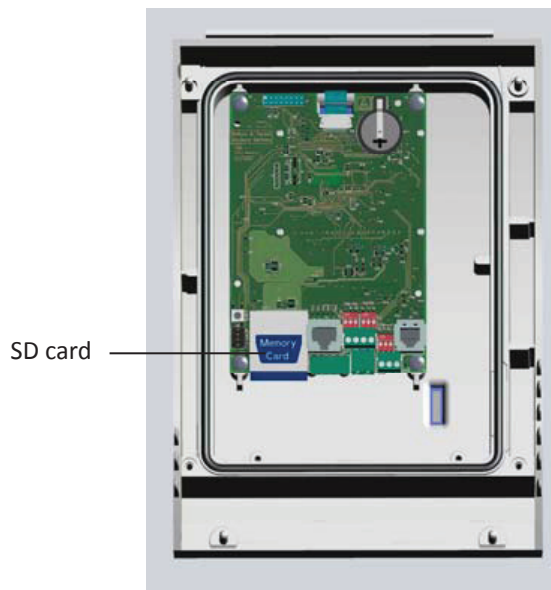

Figure 3.22 - Installed SD card

NOTE: Files ending with "*.Bin" can not be evaluated. They are only used as data storage for the SFC and must not be altered.

3.15 Unit Configuration

The SFC gives the option of saving all unit settings as a configuration. Unit settings include all parameters that can be set in the menu, such as the controller mode, setpoint, limit values, etc. A maximum of two configurations can be saved in the internal memory SFC (see Menu-System-Configurations-Save-Config 1, Config 2).

If configurations are saved in the internal memory as Config 1 and Config 2, they can be restored when required as the current unit settings. The previous unit settings are deleted in the process. It is possible to switch between Config 1 and Config 2 via digital input 1 or 2 (see Menu-Inputs/Outputs-Digital input-DI (1), DI (2)).

When "Config 2" is selected, a signal on the digital input causes configuration 2 to be loaded, and the SFC continues to operate with the unit settings of Config 2. If the signal on the digital input is deactivated, then configuration 1 is loaded again and the SFC continues to operate with the unit settings of Config 1.

3.15.1 Unit Configuration of SD Memory Card

For data backup purposes, internally saved configurations can be copied to the SD memory card (see Menu-System-Configurations-Copy-Config 1 -> SD, Config 2 -> SD).

The config file copied to the SD card (directory "JOB"-JOB1.Bin, JOB2.Bin) can be copied with any laptop/PC with a card reader, and can be transferred to other SFC systems via SD card (see Menu-System-Configurations-Copy-SD -> Config 1, SD -> Config 2, SD Config 1 -> act.* SD Config 2 -> act.*).

* act. refers to the current unit setting

SECTION 4

SECTION 4 - OPERATION

List of Contents

| | PARA. NO. |
|-------------------------------------|-----------|
| Display and Operator Controls | 4.1 |
| Notes On Operation..... | 4.2 |
| Password | 4.2.1 |
| Operation | 4.2.2 |
| Menu Structure | 4.3 |
| Main Menu..... | 4.3.1 |
| Errors | 4.4 |

4.1 Display and Operator Controls

Graphic display and operating panel

All information is shown on the graphic display.

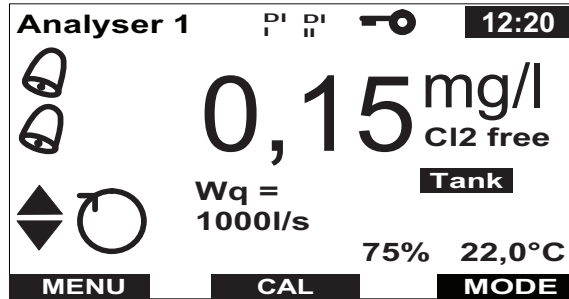

Figure 4.1 - Graphic display

The SFC is operated with nine keys. The software function is controlled with the top three keys (softkeys).

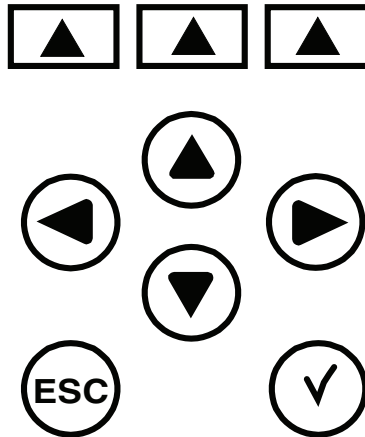

Figure 4.2 - Operating panel

The exact depiction of the individual parameters on the graphic display is described in section 4.3, Menu Structure.

Indicators

CONTROL 1



System name (Entered under "System" - "Common" - "System name")

Digital inputs 1 and 2 active.

The symbols indicate that a function has been selected for the digital signal and that a signal is pending.



Password active

The defined password must be entered to permit modification of parameters and for calibrating the device.



Time

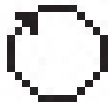

"AUTO" operating mode active

The control unit is running in automatic mode. Dosing is performed automatically.



Positioner is started, dosing pump on

Positioner stopped, dosing pump on



Pulse pump on, 15 pulses/min in the example



"MANUAL" operating mode active

Dosing can be set manually.



Alarm on

Upper alarm symbol corresponds to Alarm 1, beneath it are alarms 2 - 4



"System stopped" operating mode

Dosing is switched off.



"Adaption" operating mode is active during "Automatic" operation

Automatic determination of the control parameters for single feedback closed loop control is active.



"Adaption" operating mode is active during "Manual" operation.

Automatic determination of the control parameters for single feedback closed loop control is active.



Bar graph

This indicates a measured value, the measuring range (column height), limit values (▲ and ▼) as well as the setpoint, W_i (internal setpoint), W_e (external setpoint), D_i (internal dosing factor), D_e (external dosing factor).

Softkeys

| | | |
|----------------|----------------|---|
| BREAK | | Current softkey assignments Stop the adaption procedure. |
| SELECT | | Select one or more options from the list provided. |
| CHANGE | | Change the operating mode. |
| ENTER | | Confirm selection/Save input. |
| CAL | | Select the "Calibration" menu. |
| LOCK | | Activate password protection. |
| MENU | | Select a menu. |
| MODE | | Select the "Mode" menu. |
| UNLOCK | | Start deactivation of password protection. |
| BACK | | Move back one menu level. |
| ---> | | Open next diagnosis display. |
| START | | Starts adaption. |
| | 13s | The time until dosing resumes after interruption. |
| ADAPT | | Opens the display for adaption |
| | 100% | If the display blinks, the positioner is in manual mode and cannot be activated. |
| | 28.4°C | Sample water temperature |
| mA? | 1/5 | Error indication active (display bottom right) The system has detected an error. The error can be specified with the table in section 4.5 "Errors". The number combination states the series number of the error message and the total number of error messages (in this case the first error of a total of five). |
| | PI 85 s | YPI stop time display. The time it takes after a spike in the flow rate for the single feedback closed loop control in the combi-control to reactivate. |
| | } | Scroll bar This is used to indicate the actual menu position of the menu arrow. If the selection mark is at the top, the menu arrow is on parameter 1 (see example). A maximum of eight parameters per display is possible. |

TANK

The SFC provides the option to assign a customer-specific name or designation to each measurement. In the menu “System Module designation”, you can name each measurement as desired up to six characters, such as “Inlet”, “Main”, “Tank”, etc. This name is displayed in the main display under the associated measurement. If blanks (default setting) are entered as a module name, it is deactivated and does not appear in the main displays.

General messages

Adaption is running!

This message appears if an attempt is made during adaption to automatically calibrate the positioner.

This function is possible in the MANUAL mode only!

This message appears, for example, if an attempt is made to calibrate the positioner during automatic operation. Acknowledge by pressing ENTER or the ESC key.

A module was removed!

Do you wish to accept this configuration?

This message appears when the device is switched on after removal of a module. Confirm with the yes/no key.

New hardware component found!

This message appears when the device is switched on after addition of a module.

No data available!

This message appears when there is no configuration saved on the SD card and an attempt is made to load a configuration from the SD card.

No measurement available!

This message appears when the SFC is operated in application 1 or 2 and no sensor measuring module has been loaded.

Data are not compatible!

This message appears when a configuration is loaded from an SD card and may be caused by the following:

- Sensor measuring module different from the current measuring module
- The software version of the front panel board is different from the current version

No SD card available!

An attempt was made to save a configuration on an SD card, but no SD card was loaded or the SD card is faulty.

Function is not possible!

It is not possible to calibrate the positioner feedback at the CAN actuator.

NOTE: Information on the plug-in cards which are contained in the device are displayed in “Analog scan” when it is switched on or can be viewed statically in the “Diagnosis” menu under “Software Versions”.

Operator Controls



Softkey

- Activate the function shown on the graphic display with the keys.



Up

- Move up one level.
- Display the previous option.
- Increase the value.



Down

- Move down one level.
- Display the next option.
- Decrease the value.



Left/right

- Change the column in the menu.
- Change the position in the displayed value (cursor menu).
- Move forwards or backwards by six hours in the trend graph.



Escape

- Cancel the entry without saving the new value.
- Move up one menu level.



Enter/Acknowledge

- Acknowledge alarm message.
- Set the running delays to zero.
- Delete adaption error.
- Acknowledge max. dosing time to reactivate dosing.

4.2 Notes On Operation

During operation observe the following points:

- Check your entry and modifications before exiting the menu.
- Only press the keys with your fingers, never with hard or pointed objects such as pencils, etc. This could damage the sealed keypad.

4.2.1 Password

The system runs with up to two passwords to ensure protection against unauthorized or inadvertent changing of parameters:

- The system password permits full access to all setting options.
- The calibration password only permits access to the calibration menu and the display of the menus.

Each password is a four-digit number combination.

NOTE: The password is not pre-set at the factory (four zeros). A calibration password can only be set if a system password has been set. If the password protection was not activated with the “LOCK” softkey after entry/calibration, the system is automatically locked one hour later. The password can be changed after correct entry of the existing password.

4.2.2 Operation

You have the following options starting from the basic display (the basic display is opened by pressing the "ESC" key in the menu four times):

| | |
|--|---|
| Switch between the basic displays and trend graphs | <ul style="list-style-type: none"> • Press the up or down key |
| Select menu | <ul style="list-style-type: none"> • Press the "MENU" softkey to select the menu • Press the "CAL" softkey to calibrate • Press the "MODE" softkey to set the operating mode |
| Select a menu item in the menu display | <ul style="list-style-type: none"> • Select the menu item with the arrow keys (arrow in front of menu item) • Confirm the selection with "ENTER" |
| Change/enter displayed parameters | <ul style="list-style-type: none"> • Select the parameter with the arrow keys (arrow in front of parameter) • Confirm the selection with "ENTER" • Change/enter the display with the up or down arrow keys • Confirm the entry with "ENTER" |
| Cancel entry | <ul style="list-style-type: none"> • Press the "ESC" key to exit the menu item. Entries which have not been confirmed are reset to their original settings. |
| Reactivate password protection | <p>This function is only active when a password has been programmed.</p> <ul style="list-style-type: none"> • Change/enter displayed parameters • Block the system entry with the "LOCK" softkey in the menu display |
| Exit the menu item | <ul style="list-style-type: none"> • Press the "ESC" key or • Press the "BACK" softkey |

4.3 Menu Structure

The SFC has various menus:

- Main menu
- Module type, e.g. Cl₂ free 1
- Inputs/Outputs
- Alarms
- System
- Diagnosis
- Calibration
- Mode

Display of these depend on the number of sensor measuring modules installed.

The “Calibration” and “Mode” menus are opened with the corresponding soft keys directly from the basic display. All other menus can be accessed with the “MENU” softkey.

The following pages show the individual menus. The displays contain the default settings.

NOTE: The actual displays on your device can vary from those illustrated. The displays and menu depend on the number of sensor measuring modules installed and the selected settings.

4.3.1 Main Menu

Basic display 1

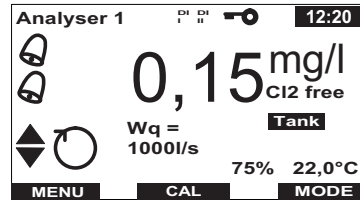

Basic display 2

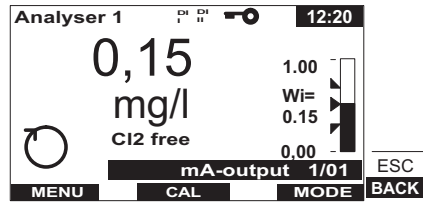

Basic display 3

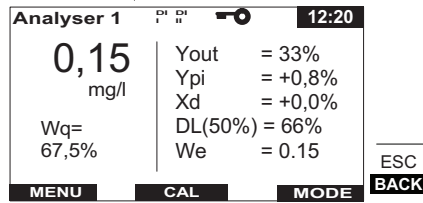

Trend graph 1

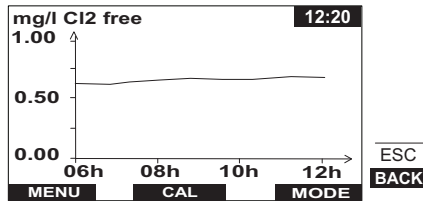

Trend graph 2

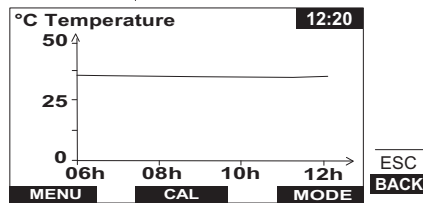

Basic Display 1

Top status line

- System name
- Digital inputs activated
- Password protection activated
- Time

Center display range

- Mode
- Measured value, e.g. free chlorine (mg/l) as a digital display with module designation (optional)
- Flow rate display Wq
- Alarm relay display
- Control output
- Feed delay (s), e.g. following sample water stop or change of mode from manual to automatic
- Fault message (instead of positioner feedback, temperature and feed delay) In the case of several fault messages the display alternates.
- Sample water temperature (°C)

Bottom status line

- Softkey display

Basic Display 2

Top status line

- See basic display 1

Center display range

- Mode
- Measured value display with bar graph display

Bottom status line

- See basic display 1

Basic Display 3

Top status line

- See basic display 1

Center display range

- Measured value display
- Flow rate display
- Controller-specific input/output variables, such as Y_{out} , Y_{pi} , X_d , dosing capacity DL depending on W_q , setpoint value W_i/W_e

Bottom status line

- See basic display 1

Trend Graph (2 max.)

Top status line

- Unit and type of the selected measurement parameter
- Date of the displayed diagram

Center display range

- 6-hour trend graph (can be scrolled back by up to 30 days with option SD card)

Bottom line

- Softkey display

SFC-PC CONTROLLER

Module Type - Menu

Display using the example of a free chlorine measurement.

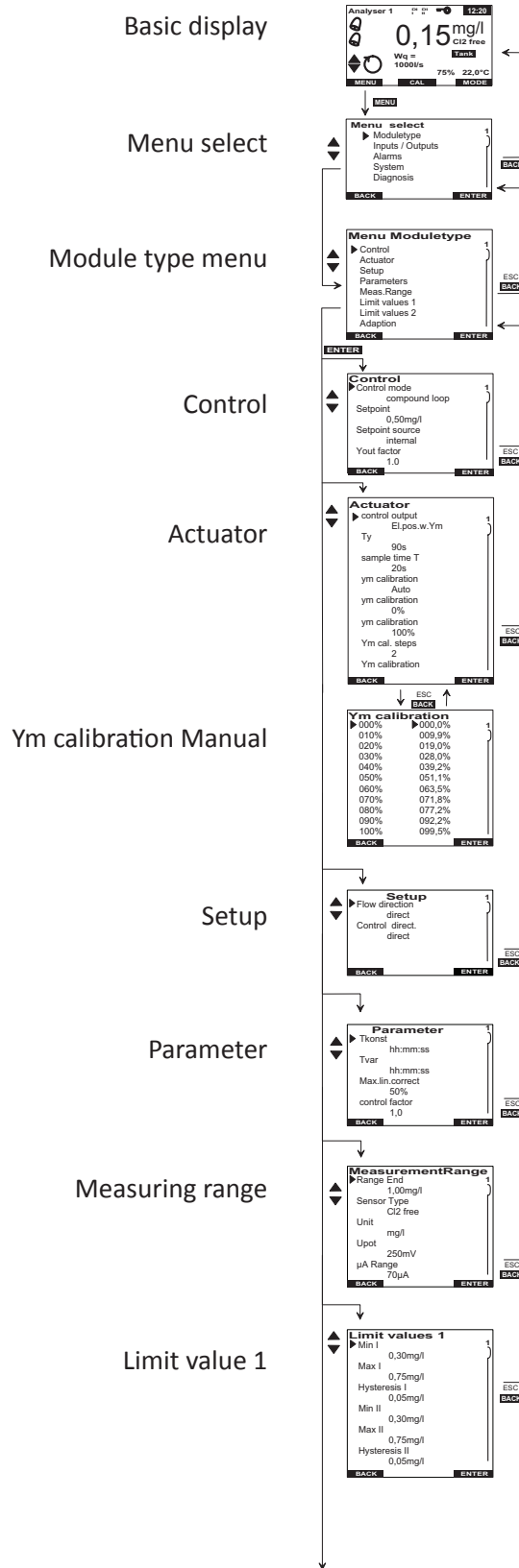

Module Type - Menu

Display using the example of a free chlorine measurement.

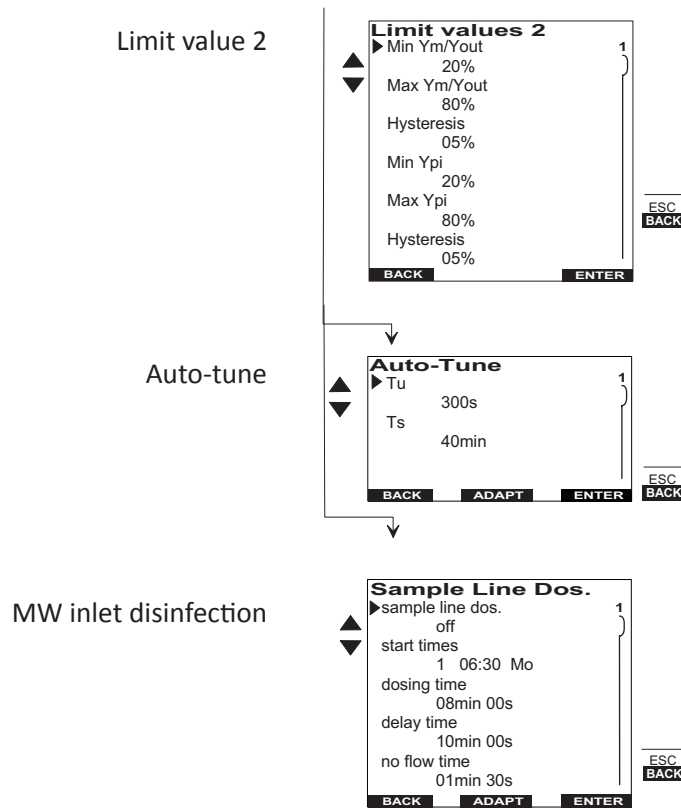

NOTE: The displayed menus and selection parameters depend on the sensor measuring module installed and the selected application. All the parameters illustrated here are not displayed at the same time.

Basic Display

Refer to main menu

Selection Menu

Display of all available menus

Module Type (1) Menu

Display of all available settings for module type 1

Control

| | |
|------------------|--|
| Control mode | Combined/ratio/single feedback (combined and ratio only available with modules with PC option) |
| Setpoint | Measuring range |
| Setpoint source | internal / external / internal with DI 2/ external with DI 2 |
| Dosing factor | 0–100% |
| Dos. fact source | internal / external / internal with DI 3/ external with DI 3 |
| Yout-factor | 1.0 - 4.0 |

Actuator

| | |
|---------------------|---|
| Control output | Positioner with Ym Positioner without Ym CAN-Bus actuator Dosing pump 2p. Dosing pump 3p. Solenoid pump 2p. Solenoid pump 3p. Analog output 2p. Analog output 3p. Dosing contact |
| CAN slave addresses | ---(off), 00...31 |
| Tp | 10 s - 180 s (60 s) |
| Ty | 10 s - 180 s (90 s) |
| Sample time T | 1 - 20 s |
| Ym calibration | Auto |
| Ym calibration | Manual |
| Ym calib. points | 2, 3, 6, 11 |
| max. Pulse/min | 100/120/140/160/180 |
| Hysteresis | Depending on measuring range 0.01 - 0.50 / 00.1 - 5.0 / 1 - 50 |
| min. ON | 1min00s - 59min59s |

Setup

| | |
|--------------------|--------------------------------|
| Flow source | Off / flow rate measured value |
| Flow direction | direct / inverse |
| Control variable 2 | Off / measured value X |
| X direction | direct / inverse |
| Control direction | direct / inverse |
| X factor | 0.1 to 4.0 |
| Ymin | 0–100% |
| Ymax | 0–100% |

Parameter

| | |
|-----------------|------------------|
| Xsh | 0.0 to 5.0 % |
| Tconst | 30 s – 10 min |
| Tvar | 30 s – 10 min |
| Max. lin. corr. | 0–100% |
| Control factor | 0.1 to 10 |
| Xp | 1–1000% |
| Tn | 0.0 to 100.0 min |

Measuring Range

Range Start

Adjustment of measuring range initial value:
mA/V Any combination

Range End

Adjustment of the measuring range end value:
mA/V Any combination

Unit

Selection of the displayed unit value.
mA/V 5 characters max. (any combination)

Format

Selection of the displayed number format for mA/V

Sensor modules:
000.0 / 00.00 / 0000

Signal

Setting the connected measurement signal:

0–20 mA, 4–20 mA, 0–10 V, CAN external

Complete electrical connection according to this setting (see section 5, SFC Schematic Wiring)

Factor

Factor to adapt an external input signal:

0.1 to 4.0

CAN Address

| | | | | | | |
|--|--|--|--|--|--|------|
| | | | | | | mA/V |
|--|--|--|--|--|--|------|

Only with sensor type mA/V:

Allocation of the measurement to be obtained via CAN bus.

Limit Value 1

| | |
|------------|--|
| Min I | within measuring range |
| Max I | within measuring range |
| Min II | within measuring range |
| Max II | within measuring range |
| Hysteresis | Depends on measuring range 0.01 to 0.25 / 00.1 to 05.0 / 1 to 50 |

Limit Value 2

| | |
|-------------|---|
| Min Ym/Yout | 0–100.0% (not in single feedback closed-loop control) |
| Max Ym/Yout | 0–100.0% (not in single feedback closed-loop control) Ym is only output if the actuator feedback is present, otherwise the controller output is Yout |
| Hysteresis | 0.1 to 5.0% |
| Min Ypi | 0–100.0% (for combi-controller only) |
| Max Ypi | 0–100.0% (for combi-controller only) |
| Hysteresis | 0.1 to 5.0% (for combi-controller only) |

Adaption

Adaption is only available for single feedback closed-loop control with “DES” modules.

| | |
|----|---------------------------|
| Tu | 1–3600 s (60 s) |
| Ts | 0.1 to 480.0 min (10 min) |

SFC-PC CONTROLLER

Inputs/Outputs - Menu

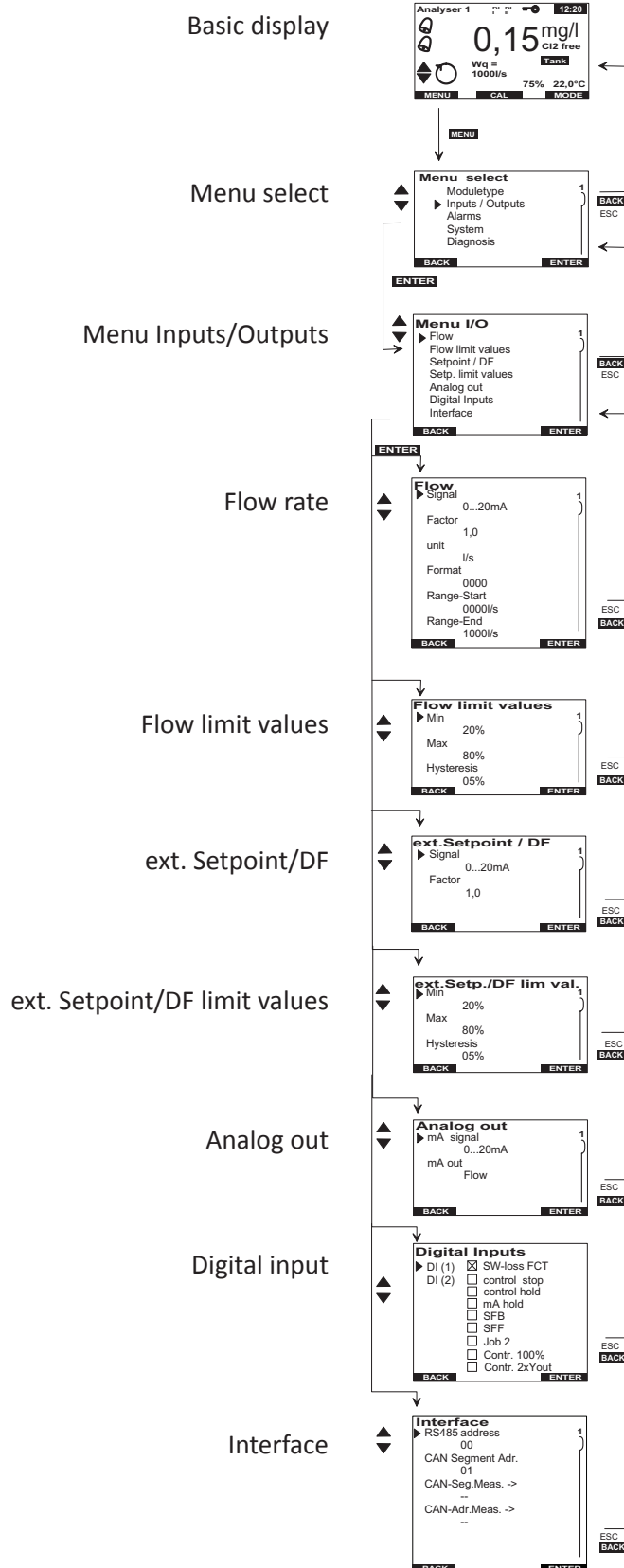

Basic Display

Refer to main menu

Menu Select

Display of all available menus

Menu Inputs/Outputs

Display of all available input/output settings

Flow Rate

| | |
|-------------|---|
| Signal | 0–20 mA, 4–20 mA, 0–10 V |
| Factor | 0.1 to 4.0 |
| Unit | Max. 5 digits (any combination) |
| Format | Measurement display 000.0 / 00.00 / 0000 |
| Range-start | Unlimited |
| Range-end | Unlimited |

Flow Rate Limit Value

| | |
|------------|--|
| Min | Min. limit value within measuring range |
| Max | Max. limit value within measuring range |
| Hysteresis | 0.1 to 5.0% |

Ext. Setpoint/DF

| | |
|--------|------------------|
| Signal | 0–20 mA, 4–20 mA |
| Factor | 0.1 to 4.0 |

Setpoint DF Limit Values

| | |
|------------|---|
| Min | Min. limit value of the external signal input 0–100.0% |
| Max | Max. limit value of the external signal input 0–100.0% |
| Hysteresis | 1–25% |

Analog Output

| | |
|-----------|---|
| mA signal | 0–5mA, 0–20 mA, 4–20 mA, 0–10 mA, off |
| mA | Measured value sensor module, flow rate Wq, ext. Setpoint/DF, Yout/Ym, Ypi |

Digital Input

| | |
|--|---|
| DI (1), DI (2) MW-STOP funct. (only with DI (1)) | Every digital in put can be assigned a function. Yout=0%, dosing, mA continuous = 0% if DI is activated, the feed stops after the preset sample water delay. If DI is deactivated, the feed starts after the preset feed delay. See Menu - System - Safety |
| Control stop Controller const | Yout = 0%, dosing, mA continuous = 0% Yout remains constant (i.e., the control signals are kept constant). |
| mA const | All mA outputs remain unchanged, while DI is active. |
| Ratio | If the DI is active, the control mode switches to ratio control. |
| Single feed back | If the DI is active, the control mode switches to single feedback closed loop control. |
| Job 2 | If the DI is active, the device switches to the settings of configuration 2. |
| Contr 100% | If the DI is active, the controller output switches to Yout = 100%. |
| Contr 2x Yout | If the DI is active, the controller output Yout is doubled. |

Interface

| | |
|------------------------------|---|
| RS485 address CAN segment | Bus addresses 00 to 31 (0) Setting the segment address in the CAN bus -- (CAN bus turned off) 01...31 |
| CAN seg. (Sens)> | Setting the CAN segment in which the measured value is to be transmitted -- (off) 01...31 |
| CAN addr. (Sens)> | Setting the CAN address with which the measured value is transmitted -- (off) 00...31 |

Alarm - Menu

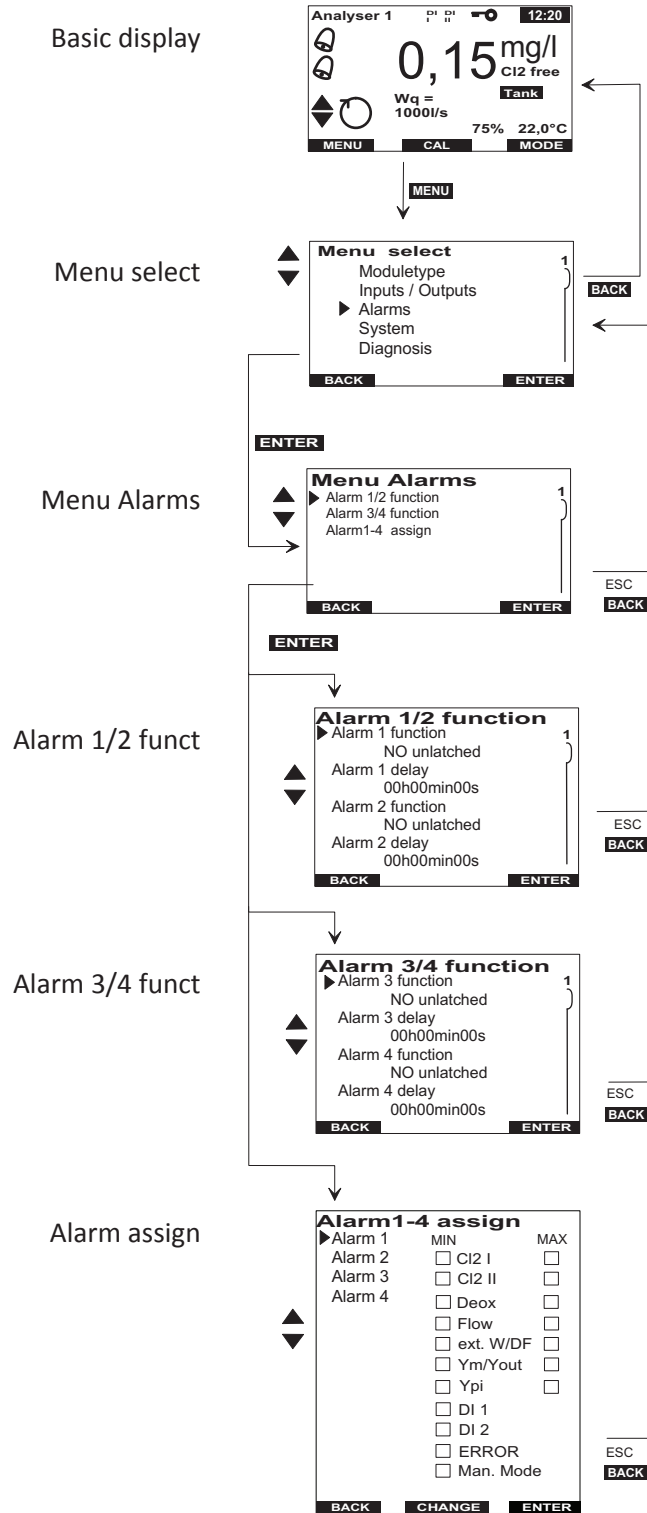

Basic Display

Refer to main menu

Menu Select

Display of all available menus

Menu Alarms

Display of all available settings

Alarm 1/2 Function

| | |
|---------------|---|
| Alarm 1 func | Defines the alarm relay contact conditions, if the alarm is inactive. N.O. unlatched N.C. unlatched N.O. latched with reset N.C. latched with reset N.O. latched with confirmation N.C. latched with confirmation |
| Alarm 1 delay | 00:00 – 10:00 h ON delay |
| Alarm 2 func | See description of alarm 1 |
| Alarm 2 delay | See description of alarm 1 |

Alarm 3/4 Function

| | |
|---------------|----------------------------|
| Alarm 3 func | See description of alarm 1 |
| Alarm 3 delay | See description of alarm 1 |
| Alarm 4 func | See description of alarm 1 |
| Alarm 4 delay | See description of alarm 1 |

Alarm Assignment 1/2/3/4

This parameter gives the option of defining the switching conditins for the alarms:

- Min I and Max I of the measurement of the sensor module
- Min II and Max II of the measurement of the sensor module
- Min and max of the flow rate Wq
- Min and max of the external setpoint/doing factor
- Min and max of the controller output Y_{out} or Y_m
- Min and max of the controller output Y_{pi}
- Digital input DI (1)
- Digital input DI (2)
- Fault
- Manual operating mode

SFC-PC CONTROLLER

System - Menu

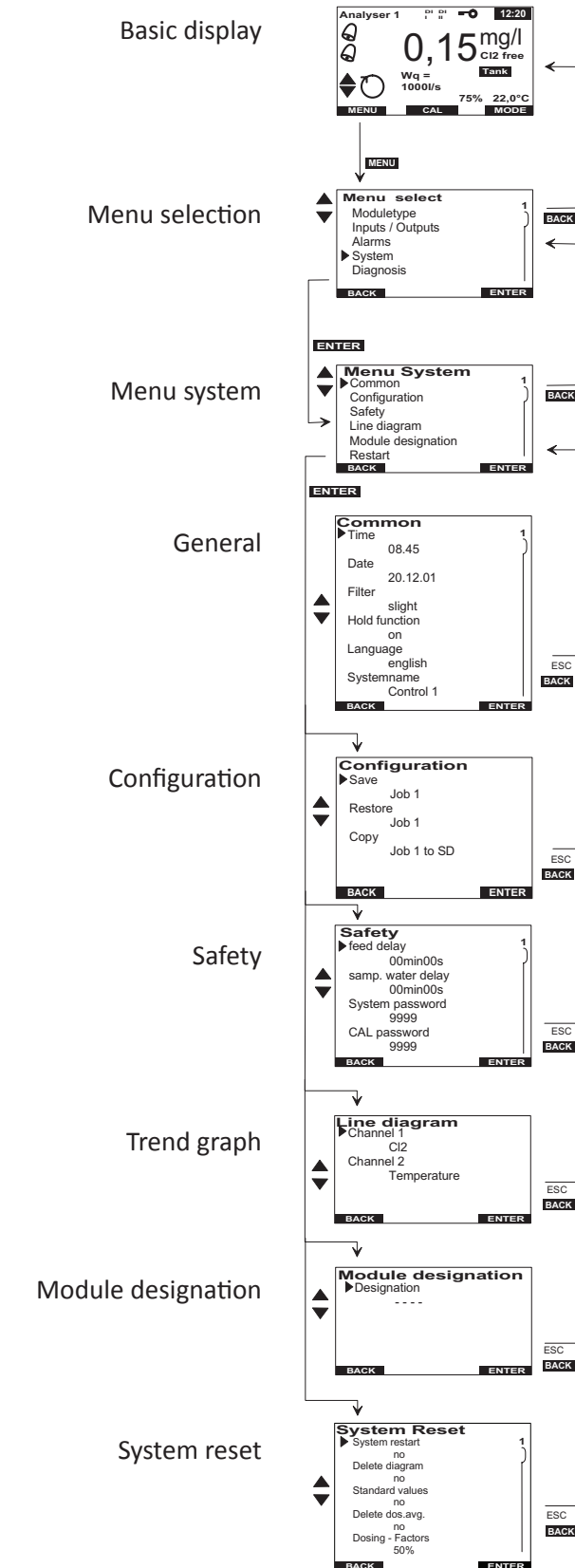

Basic Display

Refer to main menu

Menu Select

Display of all available menus

Menu System

Display of all available system settings

General

| | |
|------------------------------|--|
| Time (hh:mm) | Current time |
| Date (dd.mm.yy) | Current date |
| Measuer filter ¹⁾ | off / low / high |
| Hold function | Off / On (Keeps the measured value constant during calibration) |
| Language | German, English, French, Dutch |
| System name | 12 characters, each with character set A-Z and digits 1-9 including special characters |

Safety

| | |
|---------|--|
| Save | Gives the option of saving all device settings, including the application, as Job 1 or Job 2 |
| Restore | Gives the option of restoring saved or stored configurations. The current menu settings are overwritten in the process. Job 1 or Job 2 |
| Copy | If an SD card is installed, the configurations Job 1 and Job 2 can be copied to and from the SD card. The current operating configuration (cur.) can also be copied. Job 1 -> SD, Job 2 -> SD, SD -> Job 1, SD -> Job 2, SD Job 1 -> cur., SD Job 2 -> cur., cur. -> SD Job 1, cur. -> SD Job 2 |

Safety

| | |
|---------------------------------|---|
| Feed delay ²⁾ | 00:00 – 10:00 (03min : 00s) |
| Samp. water delay ³⁾ | 00:00 – 10:00 (01min : 00s) (sample water delay) |
| System password | four-digit numeric code (activate with Softkey "LOCK" in the "Menu Select" window) |
| Calib password* | four-digit numeric code (activate with Softkey "LOCK" in the "Menu Select" window) |

* only if system password is set

Trend Graph

Channel 1 to 2

Assignment of a measured value to the trend graph. The selected measured value is plotted in the trend graph (can be traced back up to 30 days if the SD card is installed, without the SD card from 0 to 24 hours). Options include the measured value from the sensor measuring module, external set-point/dosing factor, temperature, output signal Yout. If the setting is "selected", the relevant channel is not logged.

NOTE: If Ym is available, the Yout value is displayed in Ym.

Module Designation

Module

Max. 7 characters, customized entry. If blanks are entered, the module description is switched off. The designation is shown on the main display beneath the unit.

System Reset

| | |
|---------------------------------|----------|
| System restart ⁴⁾ | yes / no |
| Delete graph ⁵⁾ | yes / no |
| Standard value ⁶⁾ | yes / no |
| Delete dos. avg ⁷⁾ | yes / no |
| Delete DL diagram ⁸⁾ | 0–100% |

NOTE: The system settings marked with ¹⁾ to ⁸⁾ are explained below.

Explanation of System Settings

¹⁾Measure. filter

The measurement filter serves to compensate measurement value fluctuations in the event of irregular measurement value signals.

²⁾Feed delay

The feed delay delays dosing start when the device is switched on and when the operating mode has been changed. Running of the selected time can be cancelled with the "Acknowledge" key.

³⁾Samp.water delay

The sample water delay (DI 1) determines the time after which dosing is deactivated, e.g. in the event of sample water stop. DI 1 flashes while the delay time is running.

⁴⁾System restart

When the applications are changed, the device must be restarted with System Restart.

⁵⁾Delete graph

The stored measured values of the trend graph are deleted.

⁶⁾Standard values

Deletes customer settings (except for the selected application), resets system to factory settings. The sensors must be recalibrated.

⁷⁾Delete dos.avg

The dosing average is set to zero.

⁸⁾Delete DL diagram

Resets the dosing factor table to the set value and all training meters to zero.

SFC-PC CONTROLLER

Diagnosis - Menu

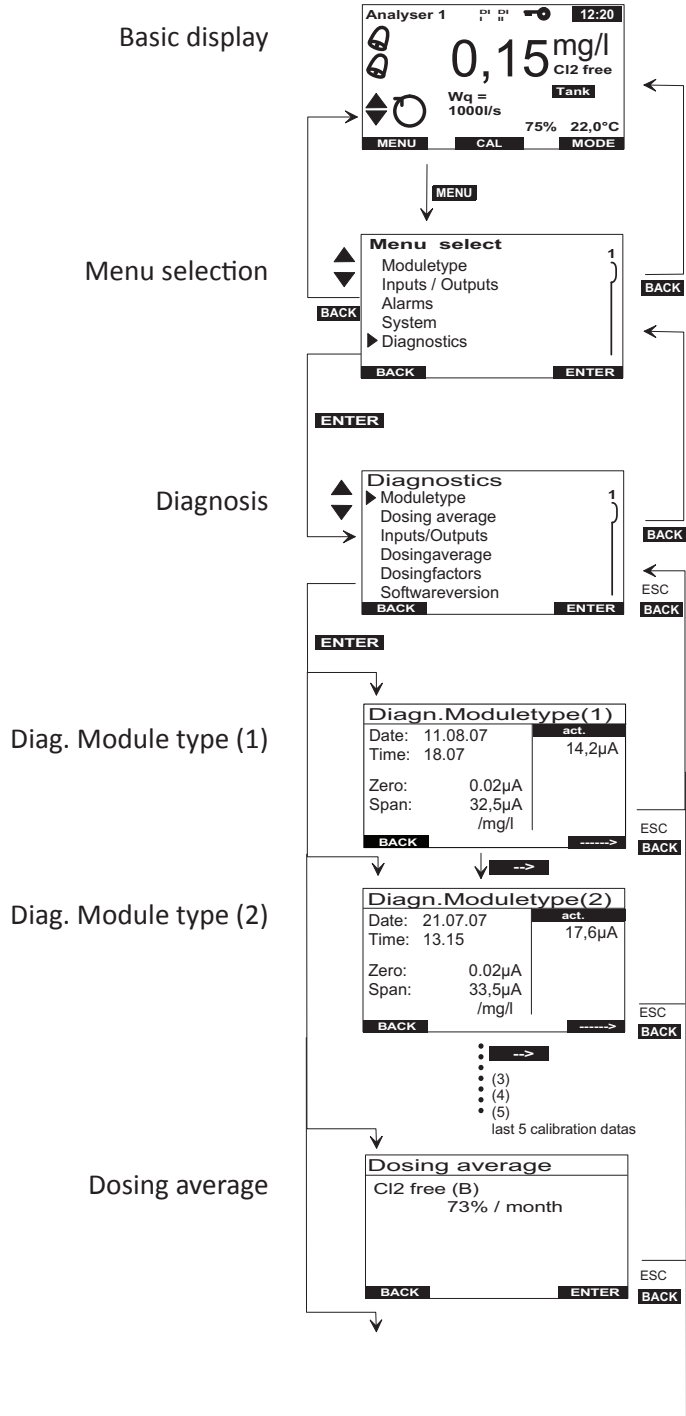

SFC-PC CONTROLLER

Basic Display

Refer to main menu

Menu Select

Display of all available menus

Diagnosis

Display of all available diagnosis displays

Diagnosis Dosing Average

Displays the dosing average of the previous hour, day, week, month.

SFC-PC CONTROLLER

Diagnosis - Menu

"Diagnosis Menu" continued

Inputs/Output diagnosis

| | |
|------------------------------|--|
| Diagnostic I/O | |
| mA: Mod 1 9,1mA/ 32% | |
| K 1 <input type="checkbox"/> | 2 <input type="checkbox"/> 3 <input type="checkbox"/> 4 <input type="checkbox"/> |
| DI1 <input type="checkbox"/> | 2 <input type="checkbox"/> |
| App: 2 RS585 RXD CANe | ESC |
| Opt: 1 RS232 TXD CANi R T | BACK |
| BACK | -----> |

Inputs/Output diagnosis

| | |
|-----------------------|----------------|
| Diagnostic I/O | |
| Wq | 13,5mA 67,5% |
| Wq/DE | 6,8mA 0,34mg/l |
| Temp: | 25,8°C |
| Fbk: | 20,8% 410DIG |
| BACK | -----> |
| ESC | BACK |

Inputs/Output diagnosis

| | |
|-----------------------|---------------|
| Diagnostic I/O | |
| 0,15 | Yout = 33% |
| mg/l | YPI = +0,8% |
| Wq= | Xd = +0,0% |
| 67,5% | DL(50%) = 66% |
| | nL = 0 |
| BACK | -----> |
| ESC | BACK |

Diagnost.Dosingfactor

| | | | | | |
|----------------------------|--------|-----|------|------|------|
| Diagn.Dosingfactors | | | | | |
| Wq/% | DL/% | N | Wq/% | DL/% | N |
| 5 | 6,5 | 0 | 30 | 28,3 | 330 |
| 10 | 8,5 | 10 | 35 | 33,5 | 410 |
| 15 | 3,8 | 18 | 40 | 38,8 | 335 |
| 20 | 8,6 | 33 | 45 | 46,6 | 233 |
| 25 | 23,8 | 480 | 50 | 53,8 | 480 |
| BACK | -----> | | BACK | ESC | BACK |

Diagnost.Dosingfactor

| | | | | | |
|----------------------------|--------|-----|------|------|------|
| Diagn.Dosingfactors | | | | | |
| Wq/% | DL/% | N | Wq/% | DL/% | N |
| 55 | 55,3 | 269 | 80 | 80,3 | 96 |
| 60 | 57,5 | 560 | 85 | 83,5 | 80 |
| 65 | 63,8 | 535 | 90 | 88,8 | 43 |
| 70 | 68,6 | 233 | 95 | 95,2 | 13 |
| 75 | 75,8 | 180 | 100 | 97,8 | 2 |
| BACK | -----> | | BACK | ESC | BACK |

Diagnost.Dosingfactor

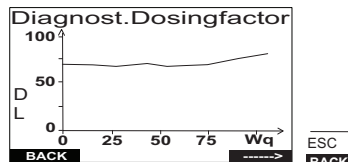

Software versions

| | |
|------------------------|---------------------|
| Softwareversion | |
| V: 01.00 | EAE1057 |
| Nov. 26 | 2007 / 09 : 07 : 13 |
| Bare Elect. Cl2 | 1.04 |
| A+C-Board | 1.00 |
| BACK | ENTER |
| ESC | BACK |

Inputs/Output Diagnosis

Information on

- The assignment of the mA outputs
- The current mA output in mA and %
- The current switching conditions of the relays:
 Relay off Relay on
- The selected application
- Display the option
- The send/receive condition of both interfaces RS485, RS232, CAN external and CAN internal
- The current switching conditions of the digital inputs 1 and 2

Second Display - Input/Output

Information on

- The current input signal of the flow rate measurement (Wq)
- The current input signal of the external setpoint (We) or external dosing factor (ext. DF) DF
- Temperature display
- Feedback signal display

Third Display - Input/Output

Information on

- Measured value module
- Combi-control Yout in %
- Ypi-share of Yout in %
- Control deviation Xd in %
- Dosing rate (DL) in % acc. to the current flow rate from the dosing factor table
- nL delay until new DL value is accepted in the dosing factor table (entry at 120)

Dosing Factor Diagnosis

Displays the learned DL dosing factors for the combi-control output depending on Wq (display in 5% increments).

N describes the training meter, how often a dosing factor was learned for this Wq value. This table can be displayed as a diagram (toggle with the ---> key).

Software Version Diagnosis

Displays the software version of the front panel boards of the sensor measuring module and the IC boards.

Mode - Menu 3

Display using an example of a chlorine measurement

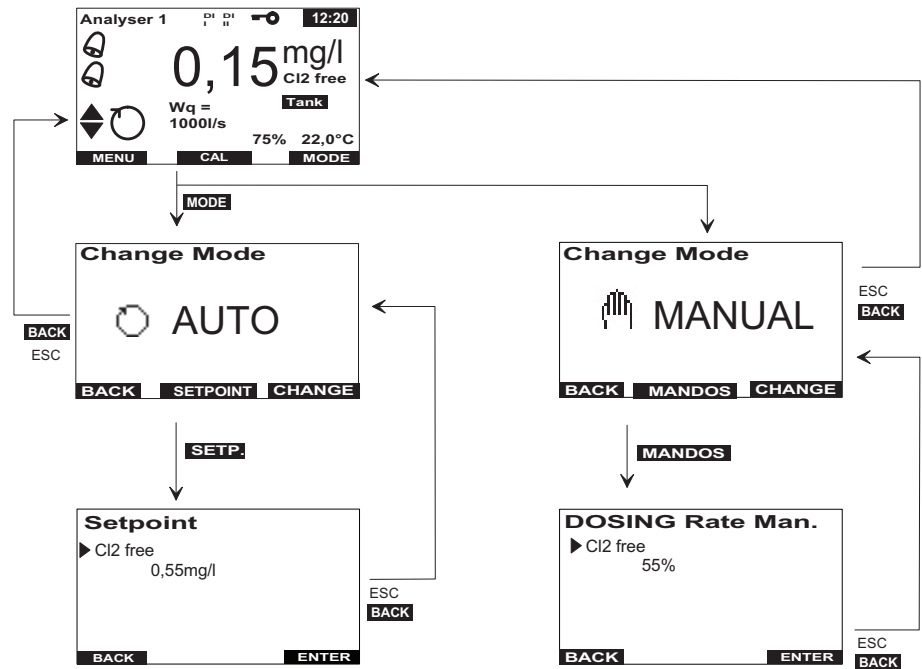

Basic Display

Refer to main menu

Manual / Automatic

AUTO / MANUAL toggle using the "CHANGE" softkey

Setpoints

Setting the setpoint or dosing factor (depending on the sensor measuring module and application)

Dosing rate MANUAL

Setting the dosing capacity for manual operation

Description of the Operating Modes

MANUAL

In MANUAL mode dosing is not automatically controlled. The values must be continuously monitored.

MANUAL mode is used:

- In the event of any possible system faults
- During maintenance/cleaning work or while checking the system

NOTE: When MANUAL mode is set: The pumps are off, the positioner remains in its current position, if necessary unlock the positioner and close either by hand or with the Man.dos. menu.

AUTOMATIC

Automatically controls the measured variables acc. to the selected application

STOP

STOP mode is automatically activated:

- When the sample water flow is faulty
- When a stop signal is received via the digital inputs

After activation:

- Pumps off, positioner closed, mA analog output 0%. If the stop conditions are no longer active, the system automatically switches to automatic mode.

ADAPTION

ADAPTION mode is activated, if the adaption for the Cl₂ single feedback closed-loop control.

For adaption refer to 3.8, Adaption.

4.4 Errors and Remedies

Error Messages

The following table shows and explains all possible error messages which can be displayed. If several errors occur at the same time, the corresponding messages appear alternately in succession. When the error has been remedied, the error message is automatically deleted.

If you are unable to remedy the error yourself, please contact your local Evoqua Water Technologies service department.

Table 4.1 - Error Message

| Error message | Cause | Remedy |
|--------------------------------|---|---|
| Measured value display flashes | Measured value is outside the measuring range | Check measuring range and change, if necessary. Check dosing or controller settings |
| Positioner feedback flashes | Positioner in manual mode | Press the adjusting nob on the positioner |
| DI I flashes | Sample water flow recently insufficient (delay running), signal at the signal input DI I | Check sample water flow rate (approx. 33 l/h) |
| DI I Permanent display | Sample water flow insufficient for some time (delay elapsed) | Clean or replace the preliminary filter Multi-sensor incorrectly connected or defective |
| DI II | Signal on signal input DI II | Check connection and setting |
| mA output? | Load error: The mA output cannot drive its mA output current through the connected current loop (500 Ohm at 20 mA max.). | Check whether the mA signal is required at all (e.g. for plotter). If not, switch off the output signal in the "INPUTS/OUTPUTS" menu (analog output). Check mA signal cable for interruption |
| Setpoint? | Due to modification of the measuring range, the controller setpoint is outside the measuring range. | Reset the controller setpoint or adjust the measuring range |

Table 4.1 - Error Message (Cont'd)

| Error message | Cause | Remedy |
|------------------------------|---|--|
| Positioner Ym? | Ym range too narrow: Position 0% or 100% incor- rectly calibrated | Check the distance between the calibration points |
| | Positioner selected, but not connected | Check setting: Positioner with Ym |
| | Feedback signal incorrect | Check DIP switch for feed- back |
| | Positioner feedback incor- rectly connected or defec- tive | Check (refer to section 5) |
| Module? | Sensor module was re- moved Sensor module defective | Refit or replace the sensor module |
| Adaption? | Adaption terminated with error | Refer to section 3.8, Adap- tion |
| Range? | Min/max limit value is out- side the measuring range | Check the min/max limit val- ues and change, if necessary |
| mA-Input 1 ? mA-Input 2 ? | mA-Input signal has been exceeded or fallen short of | Check mA connection or signal |
| Ym calibration? | Positioner calibration in- correct | Check calibration of the po- sitioner |
| CAN measure- ment? | No CAN bus station pres- ent | Check CAN bus, configure CAN station |
| CAN-actuator? | No CAN bus actuator pres- ent | Check CAN bus, configure CAN station |
| Ym display blink- ing | Positioner disconnected | Switch positioner to auto- matic |

Error

The following table shows and explains possible errors which can occur. If you are unable to remedy the error yourself, please contact the Evoqua Water Technologies service department.

Table 4.2 - Errors

| Error | Cause | Remedy |
|--|--|--|
| No indication on device | No power supply | External switch or fuse off |
| | Device fuse defective | Check the power supply and replace fuse |
| | Housing cover is fitted incorrectly | Check, fit the housing cover correctly (cable possibly trapped) |
| Displayed/output value incorrect | Change on sensor or in the sample water | Calibrate |
| Low controller quality (controller swings, setpoint not reached) | Incorrect control parameters | Check, adjust controller parameters; perform automatic adaption on single feedback closed-loop control |
| | Dosing chemical tank empty | Fill, replace |
| | Incorrect actuator selected | Check, correct actuator |
| | Positioner or pump defective | Check, replace positioner/pump |
| Measured value display not available, although the appropriate measuring module is installed | Measuring module defective or fitted incorrectly | Check, refit module correctly, replace measuring module |
| Positioner/pump does not work | Positioner in manual mode | Engage manual knob |
| | Dosing device selected incorrectly | Select correct dosing device |
| | Positioner/pump incorrectly connected | Connect the positioner/pump correctly |
| | Relay card defective or fitted incorrectly | Check, replace relay card |
| | Incorrect application | Check (refer to sections 3.4, Applications & 5, Schematic Wiring) |

Table 4.2 - Errors (Cont'd)

| Error | Cause | Remedy |
|------------------------------------|----------------------------------|-------------------------|
| Positioner runs in wrong direction | Positioner incorrectly connected | Correct connections |
| Positioner closes | Positioner feedback interrupted | Correct connections |
| Digital outputs without function | Digital inputs not activated | Activate digital inputs |

SECTION 5

SFC-PC CONTROLLER

SECTION 5 - MAINTENANCE

List of Contents

| | PARA. NO. |
|---|-----------|
| Changing the Fuse on the IC Board | 5.1 |
| Replacing the Battery | 5.2 |

5.1 Changing the Fuse on th IC Board



WARNING: ONLY AUTHORIZED AND QUALIFIED ELECTRICIANS ARE PERMITTED TO OPEN THE HOUSING. THE DEVICE IS NOT EQUIPPED WITH A MAINS SWITCH.

1. Disconnect the device from the power supply.
2. Remove the cover of the electronic module.
3. Remove screw-in fuse holder
4. Change the defective fuse.
5. Screw the screw-in fuse holder back in.
6. Reassemble the device.

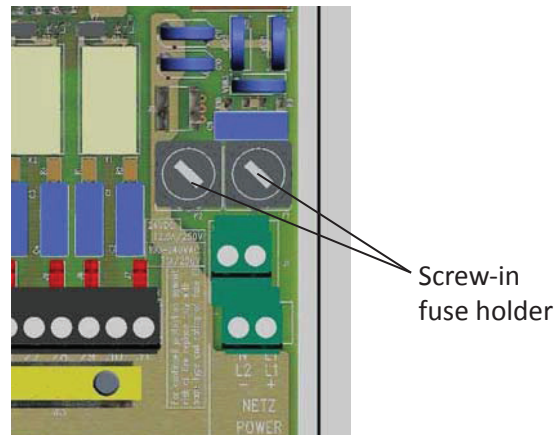

Figure 5.1 - Cutaway model of fuses

5.2 Replacing the Battery



WARNING: ONLY AUTHORIZED AND QUALIFIED ELECTRICIANS ARE PERMITTED TO OPEN THE HOUSING. THE DEVICE IS NOT EQUIPPED WITH A MAINS SWITCH.

The buffer battery is required for the real time clock in case of a power failure. If the time is not correct or if time controlled functions show faulty behavior, the battery must be changed. After five years it must be replaced.

1. Disconnect the device from the power supply.
2. Remove the cover of the electronic module.
3. Take out the old buffer battery and dispose of in accordance with the regulations.
4. Insert the new battery type CR2032.
5. Replace the housing cover.
6. Switch on the main power.
7. Set the date and time.

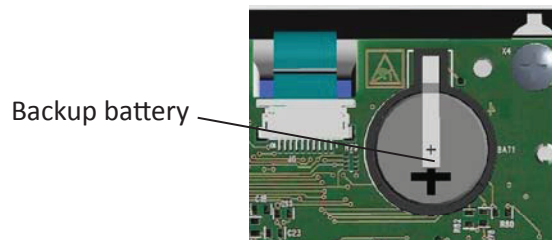

Figure 5.2 - Housing cover with battery



SFC-PC CONTROLLER

SECTION 6

SFC-PC CONTROLLER

SECTION 6 - COMPLETE DEVICES, RETROFIT KITS & SPARE PARTS

List of Contents

| | PARA. NO. |
|------------------------|-----------|
| Complete Devices | 6.1 |
| SFC Spare Parts | 6.2 |

6.1 Complete Devices



CAUTION: For reasons of safety, only use original spare parts.

Please contact our customer service department if you need any spare parts.

| Complete Unit | | Part No. |
|---|--|--------------------------|
| SFC Electronic module for wall installation | 100 – 240 V, 4x relays, 1x mA output, 1x feedback input, 2x mA input, 2x DI, temperature input, SD card slot, RS485, CAN, 1x module slot for sensor measuring module | W2T290005 |
| | 24 V DC, 4x relays, 1x mA output, 1x feedback input, 2x mA input, 2x DI, temperature input, SD card slot, RS485, CAN, 1x module slot for sensor measuring module | W3T158816 |
| SFC PC electronic module for wall installation with mA/V measuring module | 100 – 240 V, 4x relays, 1x mA output, 1x feedback input, 2x mA input, 2x DI, temperature input, SD card slot, RS485, CAN, 1x sensor measuring module for mA/V signal installed for process control | W3T158817 |
| | 24 V DC, 4x relays, 1x mA output, 1x feedback input, 2x mA input, 2x DI, temperature input, SD card slot, RS485, CAN, 1x sensor measuring module for mA/V signal installed for process control | W2T290008 |
| SFC SC electronic module for wall installation | 100 – 240 V, 2x relay, 1x mA input, 1x feedback input, 2x DI, 1x mA output | W3T158819 |
| | 24 V DC, 2x relay, 1x mA input, 1x feedback input, 2x DI, 1x mA output | W2T290009 |
| Operating Manual SFC | | WT.050.590.000. UA.IM |
| Operating instructions for retrofit set | | |
| Operating instructions RS485 bus interface of the SFC | | |

SFC-PC CONTROLLER

6.2 SFC Spare Parts

| Description | Part No. |
|--|-----------|
| Spare part circuit board IC board SFC 100 – 240 V AC | W2T348256 |
| Spare part circuit board IC board SFC 24 V DC | W2T350410 |
| Spare part circuit board IC board SFC-SC 100 – 240 V AC | W2T350411 |
| Spare part circuit board IC board SFC-SC 24 V DC | W2T350413 |
| Operating front SFC for wall mounting | W2T350415 |
| Operating front SFC-SC for wall mounting | W2T350416 |
| Basic electronics SFC 100 – 240 V wall mounting | W2T350418 |
| Basic electronics SFC 24 V DC wall mounting | W2T350506 |
| Basic electronics SFC-SC 100 – 240 V wall mounting | W2T350507 |
| Basic electronics SFC-SC 24 V DC wall mounting | W2T350508 |
| SD memory card 128 MB or larger | AAD8572 |
| Connection cable IC board front panel board approx. 0.5 m | W2T350529 |
| IC board fuse for 24 V DC and 100 – 240 V AC (1A time-lag) | W2T350536 |
| Varta battery CR2032 | W2T439137 |
| Update cable for SFC with 9 pin RS232-DSUB connector | W2T320242 |
| Accessory set, comprising: screws, dowels, multiple seal inserts, bolts, reducing sealing ring | AAD8146 |
| Mounting rails V2A for assembling the SFC on top-hat rail 3 Meter Length | |